

MaxiAlign IWA500



Patent

This product is protected by patents in the U.S. and elsewhere. For more information, please visit <https://autel.us/virtual-patents/>.

Trademarks

Autel®, MaxiSys®, MaxiDAS®, MaxiScan®, MaxiTPMS®, MaxiRecorder®, and MaxiCheck® are trademarks of Autel Intelligent Technology Corp., Ltd., registered in China, the United States, and other countries. All other marks are trademarks or registered trademarks of their respective holders.

Copyright Information

No part of this manual may be reproduced, stored in a retrieval system or transmitted in any form or by any means electronic, mechanical, photocopying, recording, or otherwise without the prior written permission of Autel.

Disclaimer of Warranties and Limitation of Liabilities

All information, specifications and illustrations in this manual are based on the latest information available at the time of printing.

Autel reserves the right to make changes at any time without notice. While information of this manual has been carefully checked for accuracy, no guarantee is given for the completeness and correctness of the contents, including but not limited to the product specifications, functions, and illustrations.

Autel will not be liable for any direct, special, incidental, or indirect damages, or for any economic consequential damages (including the loss of profits) as a result of using this product.

IMPORTANT

Before operating or maintaining this unit, please read this manual carefully, paying extra attention to the safety warnings and precautions.

For Services and Support



pro.autel.com

www.autel.com



1-855-288-3587 (North America)

+86 (0755) 8614-7779 (China)



support@autel.com

For technical assistance in all other markets, please refer to *Technical Support* in this manual.

Safety Information

For your own safety and the safety of others, and to prevent damage to the device and vehicles upon which it is used, it is important that the safety instructions presented throughout this manual be read and understood by all persons operating or coming into contact with the device.

There are numerous procedures, techniques, tools, and parts required for servicing vehicles, as well as the skills of the person doing the work. Because of the vast number of test applications and variations in the products that can be tested with this equipment, we cannot possibly anticipate or provide advice or safety messages to cover every circumstance. It is the automotive technician's responsibility to be knowledgeable of the system being tested. It is crucial to use proper service methods and test procedures. It is essential to perform tests in an appropriate and acceptable manner that does not endanger your safety, the safety of others in the work area, the device being used, or the vehicle being tested.

Before using the device, always refer to and follow the safety messages and applicable test procedures provided by the manufacturer of the vehicle or equipment being tested. Use the device only as described in this manual. Be sure to read, understand, and follow all safety messages and instructions in this manual.

Safety Messages

Safety messages are provided to help prevent personal injury and equipment damage. All safety messages are introduced by a signal word indicating the hazard level.

DANGER

Indicates an imminently hazardous situation which, if not avoided, could result in death or serious injury to the operator or to bystanders.

WARNING

Indicates a potentially hazardous situation which, if not avoided, could result in death or serious injury to the operator or to bystanders.

Safety Instructions

The safety messages herein cover situations Autel is aware of at the time of publication. Autel cannot know, evaluate or advise you as to all of the possible hazards. You must be certain that any condition or service procedure encountered does not jeopardize your personal safety.

 **DANGER**

When an engine is operating, keep the service area WELL VENTILATED or attach a building exhaust removal system to the engine exhaust system. Engines produce carbon monoxide, an odorless, poisonous gas that causes slower reaction time and can lead to serious personal injury or loss of life.

 **It is not advised to use headphones at a high volume**

Listening at high volumes for long periods of time may result in loss of hearing.

 **Safety Warnings**

- Always perform automotive testing in a safe environment.
- Wear safety eye protection that meets ANSI standards.
- Keep clothing, hair, hands, tools, test equipment, etc. away from all moving or hot engine parts.
- Operate the vehicle in a well-ventilated work area, for exhaust gases are poisonous.
- Put the transmission in PARK (for automatic transmission) or NEUTRAL (for manual transmission) and make sure the parking brake is engaged.
- Put blocks in front of the drive wheels and never leave the vehicle unattended while testing.
- Be extra cautious when working around the ignition coil, distributor cap, ignition wires and spark plugs. These components create hazardous voltages when the engine is running.
- Keep a fire extinguisher suitable for gasoline, chemical, and electrical fires nearby.
- Do not connect or disconnect any test equipment while the ignition is on or the engine is running.
- Keep the test equipment dry, clean, free from oil, water or grease. Use a mild detergent on a clean cloth to clean the outside of the equipment as necessary.
- Do not drive the vehicle and operate the test equipment at the same time. Any distraction may cause an accident.
- Refer to the service manual for the vehicle being serviced and adhere to all diagnostic procedures and precautions. Failure to do so may result in personal injury or damage to the test equipment.
- To avoid damaging the test equipment or generating false data, make sure the vehicle battery is fully charged and the connection to the vehicle DLC is clean and secure.
- Do not place the test equipment on the distributor of the vehicle. Strong electro-magnetic interference can damage the equipment.

CONTENTS

1 USING THIS MANUAL	1
1.1 CONVENTIONS	1
1.1.1 Notes and Important Messages	1
1.1.2 Bold Text.....	1
1.1.3 Hyperlinks	1
1.1.4 Illustrations.....	1
1.1.5 Procedures.....	2
2 GENERAL INTRODUCTION	3
2.1 AUTEL MAXIALIGN IWA500 TABLET	3
2.1.1 Function Description	3
2.1.2 Power Sources.....	6
2.1.3 Technical Specifications.....	6
2.2 MAXIVCI V200 — VEHICLE COMMUNICATION INTERFACE	8
2.2.1 Function Description	8
2.2.2 Technical Specifications.....	9
2.3 OTHER ACCESSORIES	10
3 GETTING STARTED	11
3.1 POWER UP.....	11
3.1.1 Application Buttons	12
3.1.2 Locator and Navigation Buttons	13
3.1.3 System Status Icons	15
3.2 POWER DOWN.....	15
3.2.1 Reboot System	15
4 SETTINGS	16

4.1	UNIT	16
4.2	LANGUAGE	17
4.3	PRINTING SETTINGS	17
4.4	DIAGNOSTIC SETTINGS	18
4.5	REPORT SETTINGS.....	19
4.6	PUSH NOTIFICATIONS	20
4.7	AUTO UPDATE	21
4.8	WHEEL ALIGNMENT SETTINGS.....	21
4.8.1	Common Settings	22
4.8.2	Wheel Alignment Frame Connection	30
4.8.3	Network Configuration.....	32
4.8.4	Update	34
4.8.5	Hand-held Inclinometer Update	34
4.8.6	Maintenance & Service	35
4.8.7	Wheel Alignment Software Settings.....	59
4.9	VEHICLE LIST.....	67
4.10	SYSTEM SETTINGS	68
4.11	ABOUT	68
5	DIAGNOSTICS.....	69
5.1	ESTABLISHING VEHICLE COMMUNICATION.....	69
5.1.1	Vehicle Connection	69
5.1.2	VCI Connection.....	69
5.1.3	No Communication Message	71
5.2	GETTING STARTED.....	72
5.2.1	Vehicle Menu Layout	72
5.3	VEHICLE INFORMATION IDENTIFICATION	74

5.3.1	Auto Detect	74
5.3.2	Manual Input	76
5.3.3	Scan VIN/License	77
5.3.4	Manual Vehicle Selection	78
5.3.5	OBDII Direct Entry	79
5.4	NAVIGATION	80
5.4.1	Diagnostics Screen Layout	80
5.4.2	Screen Messages	83
5.5	DIAGNOSTICS MENU	83
5.6	DIAGNOSTICS FUNCTIONS	83
5.6.1	ECU Information	85
5.6.2	Trouble Codes	86
5.6.3	Live Data	87
5.7	GENERIC OBDII OPERATIONS	94
5.7.1	General Procedure	94
5.7.2	Function Descriptions	95
5.8	DIAGNOSTICS REPORT	98
5.8.1	Pre-Scan and Post-Scan Functions	98
5.8.2	Diagnostics Report Saving, Viewing, and Sharing	98
5.9	EXIT DIAGNOSTICS	102
6	WHEEL ALIGNMENT FUNCTION	104
6.1	WHEEL ALIGNMENT FRAME SPECIFICATIONS	104
6.2	PRECAUTIONS FOR WHEEL ALIGNMENT OPERATIONS	105
6.3	BEFORE WHEEL ALIGNMENT	105
6.3.1	Preparatory Work	105
6.3.2	Function Selection	106

6.3.3	Vehicle Menu Layout	108
6.3.4	Vehicle Information Identification	110
6.3.5	Parameters Customization.....	110
6.4	WHEEL ALIGNMENT PROCEDURES.....	115
6.4.1	Vehicle Inspection.....	115
6.4.2	Preparation Work.....	121
6.4.3	Compensation.....	130
6.4.4	Caster/SAI/IA Angle Measurement	137
6.4.5	Measured Result.....	139
6.4.6	Alignment Guide	153
6.4.7	Post-alignment Diagnosis	159
6.4.8	Reports	161
6.5	GLOSSARY	176
6.5.1	Geometry Centerline.....	176
6.5.2	Thrust Angle.....	176
6.5.3	Toe.....	177
6.5.4	Total Toe.....	178
6.5.5	Camber	178
6.5.6	Front Caster.....	179
6.5.7	Steering Axis Inclination (SAI).....	180
6.5.8	Included Angle (IA)	181
6.5.9	Toe-out on Turns	181
6.5.10	Maximum Steering Angle	182
6.5.11	Ride Height.....	183
6.5.12	Setback Angle	184
6.5.13	Wheel Straight Ahead.....	185

6.5.14	Symmetrical Value.....	185
6.5.15	Rolling Diameter.....	185
7	HAND-HELD INCLINOMETER	186
8	WHEEL ALIGNMENT FILTER.....	188
9	MAXVIEWER.....	190
10	UPDATE	193
11	DATA MANAGER.....	194
11.1	VEHICLE HISTORY	196
11.1.1	Historical Test Record	197
11.2	WORKSHOP INFORMATION.....	198
11.3	CUSTOMER	198
11.4	IMAGE	199
11.5	CLOUD REPORT	201
11.6	PDF FILES	201
11.7	REVIEW DATA	201
11.8	DATA LOGGING	202
11.9	UNINSTALL APPS.....	202
12	VCI MANAGER	203
12.1	VCI BLUETOOTH PAIRING	203
12.2	VCI UPDATE.....	204
13	SUPPORT	205
13.1	SUPPORT SCREEN LAYOUT	205
13.2	MY ACCOUNT.....	205
13.3	TRAINING.....	206
13.4	DATA LOGGING	206
13.5	FAQ	206

14	REMOTE DESKTOP	207
14.1	OPERATIONS.....	207
15	QUICK LINK.....	209
16	USER FEEDBACK.....	210
17	AUTEL USER CENTER	211
18	MAINTENANCE AND SERVICE	213
18.1	MAINTENANCE INSTRUCTIONS.....	213
18.2	TROUBLESHOOTING CHECKLIST	214
18.3	ABOUT BATTERY USAGE	214
18.4	SERVICE PROCEDURES.....	215
18.4.1	Technical Support	215
18.4.2	Repair Service.....	217
18.4.3	Other Services.....	217
19	COMPLIANCE INFORMATION.....	219
20	WARRANTY	221

1 Using This Manual

This manual contains device usage instructions.

Some illustrations shown in this manual may contain modules and optional equipment that are not included in your system.

1.1 Conventions

The following conventions are used:

1.1.1 Notes and Important Messages

1.1.1.1 *Notes*

A **NOTE** provides helpful information such as additional explanations, tips, and comments.

1.1.1.2 *Important*

IMPORTANT indicates a situation that, if not avoided, may result in damage to the tablet or vehicle.

1.1.2 Bold Text

Bold text is used to highlight selectable items such as buttons and menu options.

Example:

- Tap **OK**.

1.1.3 Hyperlinks

Hyperlinks are available in electronic documents. Blue italic text indicates a selectable hyperlink; blue underlined text indicates a website link or an email address link.

1.1.4 Illustrations

Illustrations used in this manual are samples. The actual testing screen may vary for each vehicle being tested. Observe the menu titles and on-screen instructions to make

correct option selection.

1.1.5 Procedures

An arrow icon indicates a procedure. Example:

- **To power down the MaxiSys tablet**
 1. Long press (press and hold) the **Power/Lock** button.
 2. Tap the **Power Off** option.
 3. Tap **OK**.

2 General Introduction

There are two main components to the MaxiSys system:

- Autel MaxiAlign IWA500 Tablet — the central processor and monitor for the system.
- MaxiVCI V200 — the vehicle communication interface.

This manual describes the construction and operation of these devices and how they work together to deliver complete functional solutions.

2.1 Autel MaxiAlign IWA500 Tablet

2.1.1 Function Description

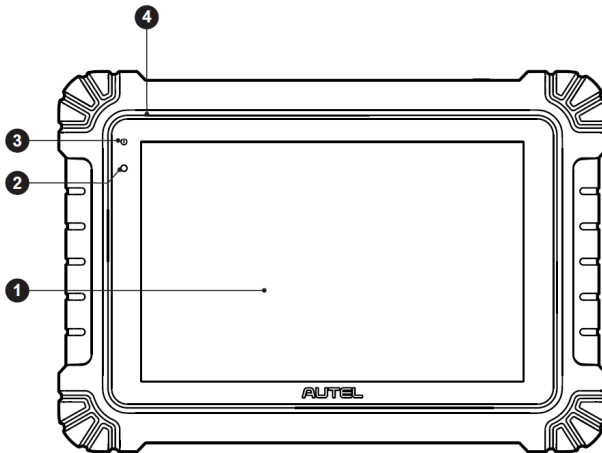

Figure 2-1 MaxiSys Tablet Front View

1. 10.1-inch TFT-LCD Capacitive Touchscreen
2. Ambient Light Sensor — detects ambient brightness
3. Power LED — refer to [Table 2-1 Power LED Description](#) for details
4. Built-in Microphone

Table 2-1 Power LED Description

LED	Color	Description
Power	Green	<ul style="list-style-type: none">• Lights green when the tablet is charging, and the battery level is above 90%.• Lights green when the tablet is powered on, and the battery level is above 15%.
	Yellow	Lights yellow when the tablet is charging, and the battery level is below 90%.
	Red	Lights red when the tablet is powered on, and the battery level is below 15%.

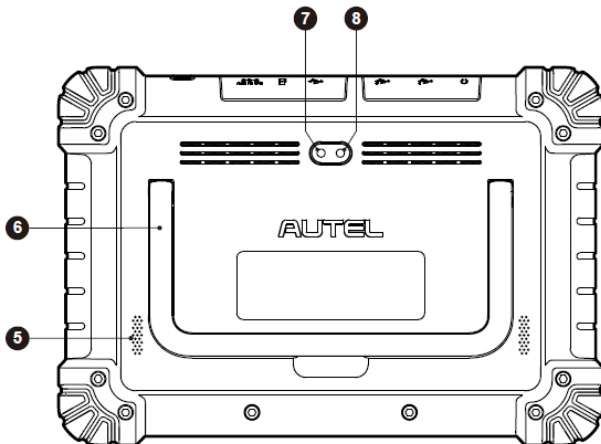

Figure 2-2 MaxiSys Tablet Back View

5. Speaker
6. Collapsible Stand — extends from the back to allow hands-free viewing of the tablet.
7. Rear Camera
8. Camera Flash

Camera

Function Description: Used for vehicle information identification, such as VIN scanning and vehicle photography.

Privacy Impact: Collects vehicle VIN data and uploads it to the cloud platform to identify the vehicle model, year, engine type, etc.

Permission Control: Camera access permissions can be disabled in system settings (Path: Settings > System Settings > Privacy > Permission Manager > Camera).

Microphone

Function Description: Used for audio and video recording through the device and its camera.

Privacy Impact: Stores recorded voice data from the recorder and camera locally.

Permission Control: Microphone access permissions can be disabled in system settings (Path: Settings > System Settings > Privacy > Permission Manager > Microphone).

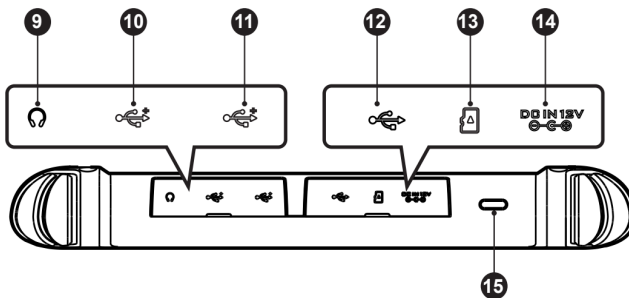

Figure 2-3 MaxiSys Tablet Top View

9. Headphone Jack
10. USB Port
11. USB Port
12. USB Type-C Port — supports charging
13. Mini SD Card Slot
14. DC Power Supply Input Port
15. Power/Lock Button — long press to turn on/off the tablet, or short press to lock the screen.

2.1.2 Power Sources

The tablet can receive power from any of the following sources:

- Internal Battery Pack
- AC/DC Power Supply
- Vehicle Power
- Type-C Power Supply

! IMPORTANT

Do not charge the battery when the temperature is lower than 0 °C (32 °F) or higher than 45 °C (113 °F).

2.1.2.1 Internal Battery Pack

The tablet can be powered with the internal rechargeable battery, which, if fully charged, can provide sufficient power for about 8 hours of continuous operation.

2.1.2.2 AC/DC Power Supply – using a power adapter

The tablet can be powered from an electrical outlet using the AC/DC power adapter. The AC/DC power supply also charges the internal battery pack.

2.1.2.3 Vehicle Power

The tablet can be powered from the auxiliary power outlet adapter or other DC power port on the test vehicle through a direct cable connection. The vehicle power cable connects to the DC power supply port on the top side of the tablet.

2.1.2.4 Type-C Power Supply

The tablet can be powered using the supplied USB Type-C cable.

2.1.3 Technical Specifications

Table 2-2 Tablet Specifications

Item	Description
Operating System	Android 10
Processor	Octa-core Processor
Memory	4 GB RAM & 128 GB On-board Memory
Display	10.1-inch LCD Capacitive Touchscreen with 1920 x 1200 Resolution

Item	Description
Connectivity	<ul style="list-style-type: none"> ● Wi-Fi (802.11 a/b/g/n/ac) ● BT 5.0 (BR/EDR + BLE) ● GPS ● USB 2.0 (Two USB Host Type A) ● USB Type-C ● SD Card (Supports up to 256 GB)
Camera (Rear)	13 MP
Sensors	<ul style="list-style-type: none"> ● Gravity Accelerometer ● Ambient Light Sensor (ALS)
Audio Input/Output	<ul style="list-style-type: none"> ● Microphone ● Dual Speakers ● 3-band or 4-band 3.5 mm Headset Jack
Power and Battery	<ul style="list-style-type: none"> ● 11600 mAh 3.85 V Lithium-polymer Battery ● Charging via 12 V DC Power Supply ● Charging via USB Type-C power supply
Input Voltage	<ul style="list-style-type: none"> ● DC input: 12 V / 3 A ● USB-C input: 5 V / 1.5 A
Operating Temp.	0 °C to 50 °C (32 °F to 122 °F)
Storage Temp.	-10 °C to 60 °C (14 °F to 140 °F)
Dimensions (L x W x H)	311.1 mm (12.25") x 216.0 mm (8.50") x 39.9 mm (1.57")
Weight	1.71 kg (3.77 lbs)

Item	Description
Protocols	PLC J2497, ISO-15765, SAE-J1939, ISO-14229 UDS, SAE-J2411 Single Wire Can (GMLAN), ISO-11898-2, ISO-11898-3, SAE-J2819 (TP20), TP16, ISO-9141, ISO-14230, SAE-J2610 (Chrysler SCI), UART Echo Byte, SAE-J2809 (Honda Diag-H), SAE-J2740 (GM ALDL), SAE-J1567 (CCD BUS), Ford UBP, Nissan DDL UART with Clock, BMW DS2, BMW DS1, SAE J2819 (VAG KW81), KW82, SAE J1708, SAE-J1850 PWM (Ford SCP), SAE-J1850 VPW (GM Class2), ISO13400, CAN FD

2.2 MaxiVCI V200 — Vehicle Communication Interface

The MaxiVCI V200 is a small vehicle communication interface (VCI) used to connect to a vehicle's DLC and the tablet for vehicle data transmission.

2.2.1 Function Description

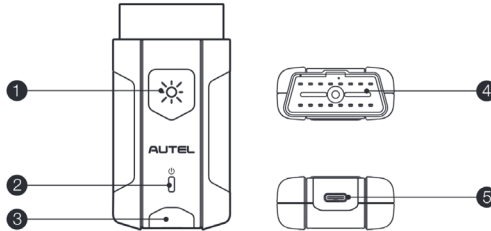

Figure 2-4 MaxiVCI V200 Views

1. Flashlight Power Button
2. Power LED — refer to [Table 2-3 VCI LED Description](#) for details
3. Vehicle/Connection LED — refer to [Table 2-3 VCI LED Description](#) for details
4. Vehicle Data Connector (16-pin)
5. USB Port

Table 2-3 VCI LED Description

LED	Color	Description
Power LED	Yellow	The VCI is powered on and performing a self-check.
	Green	The VCI is ready for use.
	Flashing Red	The firmware is updating.
Vehicle/ Connection LED	Green	<ul style="list-style-type: none"> ● Solid Green: The VCI is connected via USB cable. ● Flashing Green: The VCI is communicating via the USB cable.
	Blue	<ul style="list-style-type: none"> ● Solid Blue: The VCI is connected via Bluetooth. ● Flashing Blue: The VCI is communicating via Bluetooth.

 **NOTE**

The power LED briefly lights yellow each time the device powers on and then lights green when the device is ready.

2.2.2 Technical Specifications

Table 2-4 Technical Specifications

Item	Description
Communications	<ul style="list-style-type: none"> ● BLE + EDR ● Type-C USB
Wireless Frequency	2.4 GHz
Input Voltage Range	8 V to 30 V DC
Supply Current	150 mA @ 12 V DC
Operating Temp.	0 °C to 50 °C (32 °F to 122 °F)
Storage Temp.	-10 °C to 60 °C (14 °F to 140 °F)



Item	Description
Dimensions (L x W x H)	89.89 mm (3.53") x 46.78 mm (1.84") x 21 mm (0.82")
Weight	70.7 g (0.156 lb.)
Built-in Battery	3.7 V Lithium Battery
Light	White LED

 **NOTE**

The 3.7 V lithium battery is used for LED lighting only.

2.3 Other Accessories

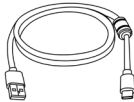
Table 2-5 Other Accessories

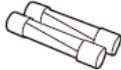
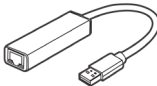
	<p>AC/DC External Power Adapter</p> <p>Connects the tablet to the external DC power port for power supply.</p> <p>NOTE: For environmental reasons, the power adapter is optional in some regions. Please refer to the Packing List for details.</p>
	<p>USB Type-C Cable</p> <p>Supports charging.</p>
	<p>Auxiliary Power Outlet Adapter</p> <p>Provides power to the tablet or the VCI device through connection to the vehicle's auxiliary power outlet adapter receptacle, as some non-OBDII vehicles cannot provide power via the DLC connection.</p>
	<p>Spare Fuse x 2</p> <p>A safety device for the auxiliary power outlet adapter.</p>
	<p>USB to Ethernet Adapter</p> <p>The network connection function can be realized through this device.</p>

3 Getting Started

Make sure that the tablet has sufficient power or is connected to the external power supply (see [Power Sources](#)).

3.1 Power Up

Press and hold the **Power/Lock** button on the top-right side of the tablet to turn it on. Swipe up from the bottom of the Lock screen to access the MaxiSys Job Menu.

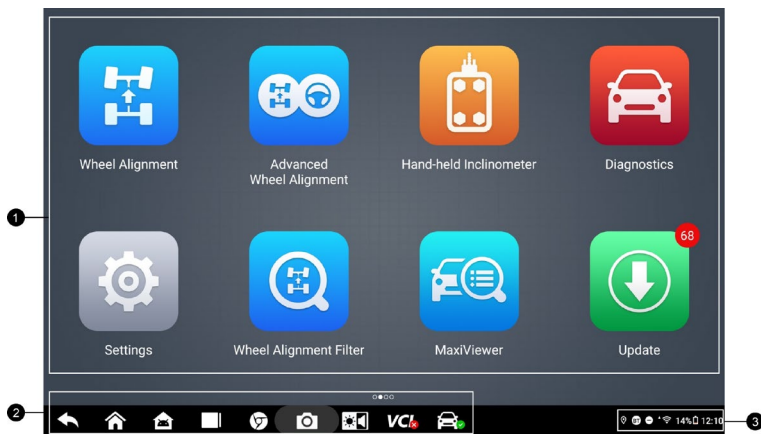

Figure 3-1 MaxiSys Job Menu

1. Application Buttons
2. Locator and Navigation Buttons
3. Status Icons

NOTE











It is recommended that you lock the screen when not in use to protect information in the system and conserve power.









Almost all operations on the tablet are controlled through the touchscreen. The touchscreen navigation is menu-driven, allowing for quick access to the test procedures or the data that you need, through a series of questions and options. Detailed descriptions of the menu structures are found in the chapters for each application.

3.1.1 Application Buttons

The table below briefly describes each application in the MaxiSys system.

Table 3-1 Applications











Button	Name	Description
	Wheel Alignment	Accesses the wheel alignment functions. See Wheel Alignment Function .
	Advanced Wheel Alignment	Accesses the wheel alignment and steering angle reset functions. See Wheel Alignment Function .
	Hand-held Inclinator	Connects your tablet to a hand-held inclinometer to measure the ride height of Mercedes-Benz vehicles. See Hand-held Inclinator .
	Diagnostics	Accesses the unit's diagnostic functions. See Diagnostics .
	Settings	Accesses the system settings menu and the general tablet menu. See Settings .
	Wheel Alignment Filter	Accesses the Wheel Alignment Filter functions. See Wheel Alignment Filter .
	MaxiViewer	Provides a quick search for supported functions and/or vehicles. See MaxiViewer .
	Update	Accesses the system software update menu. See Update .
	Data Manager	Accesses the saved repair shop, customer, and vehicle data, including detailed vehicle diagnostics and test records. See Data Manager .
	VCI Manager	Accesses VCI connection menu. See VCI Manager .

Button	Name	Description
	Support	Synchronizes Autel's online service database with the MaxiSys tablet. See Support .
	OEM Authorization	Manages the permissions for unlocking the OE gateway.
	Remote Desktop	Configures your tablet to receive remote support using the TeamViewer application. See Remote Desktop .
	Quick Link	Provides associated website bookmarks to allow quick access to product updates, service, support, and other information. See Quick Link .
	Demonstration	Provides a step-by-step operation demonstration for diagnostics.
	User Feedback	You can submit feedback through this application when you encounter problems using the tablet. See User Feedback .
	MaxiTools	Includes Log collection and Factory data reset, two parts.
	Autel User Center	Allows users to register their Autel tool to download the latest software releases. See Autel User Center .

3.1.2 Locator and Navigation Buttons

Operations of the Navigation buttons at the bottom of the screen are described in the table below.

Table 3-2 Locator and Navigation Buttons

Icon	Name	Description
	Locator	Indicates the location of the screen. Swipe the screen left or right to view the previous or next screen.
	Back	Returns to the previous screen.
	MaxiSys Home	Returns to the MaxiSys Job Menu.
	Android Home	Returns to the Android system home screen.
	Recent Apps	Displays a list of currently running applications. Tap an application icon to launch the application. Remove a running application by swiping it up. Tap Clear All to remove all running applications.
	Browser	Launches the Chrome Internet browser.
	Camera	Tap the Camera icon to open the camera viewfinder. Press and hold the icon to take a screenshot of the current screen. The saved files are automatically stored in the Data Manager application for later review. See Data Manager .
	Display & Sound	Adjusts the screen brightness and the audio output volume.
	VCI Shortcut	Opens the VCI Manager application. A green icon in the bottom-right corner indicates that the VCI device is connected, while a red "X" icon will be displayed if the connection fails.
	Diagnostics Shortcut	Returns to the Diagnostics screen.

➤ **To use the camera**

1. Tap the **Camera** icon from the navigation buttons. The camera screen opens.
 2. Focus the image to be captured in the viewfinder.
 3. Tap the **Camera** icon on the right side of the screen. The viewfinder now shows the captured picture and automatically saves the taken photo.
 4. Tap the thumbnail image in the top-right corner of the screen to view the stored images.
 5. Tap the **Back** or **Home** button to exit the camera function.
-

 **NOTE**

After swiping the camera screen from left to right, the camera mode and video mode can be switched by tapping the **Camera** or **Video** icon.

3.1.3 System Status Icons

Your MaxiSys tablet is a fully functional Android tablet with the standard Android operating system status icons. Refer to Android documentation for more information.

3.2 Power Down

All vehicle communications should be terminated before shutting down the tablet. A warning message displays if a shutdown is attempted while the tablet is communicating with the vehicle. Forcing a shutdown while the tablet is communicating with the vehicle may result in ECU errors in some vehicles. Please exit the Diagnostics application before shutting off the tablet.

➤ **To power down the MaxiSys tablet**

1. Press and hold the **Power/Lock** button.
2. Tap the **Power Off** option.
3. Tap **OK**.

3.2.1 Reboot System

In case of a system crash, press and hold the **Power/Lock** button and tap **Restart** to reboot the system.

4 Settings

Access the Settings menu to adjust default settings and view information about the MaxiSys system. The following options are available in the Settings application:

- Unit
- Language
- Printing Settings
- Diagnostic Settings
- Report Settings
- Push Notifications
- Auto Update
- Wheel Alignment Settings
- Vehicle List
- System Settings
- About

4.1 Unit

This option allows you to switch the measurement units for the diagnostics system.

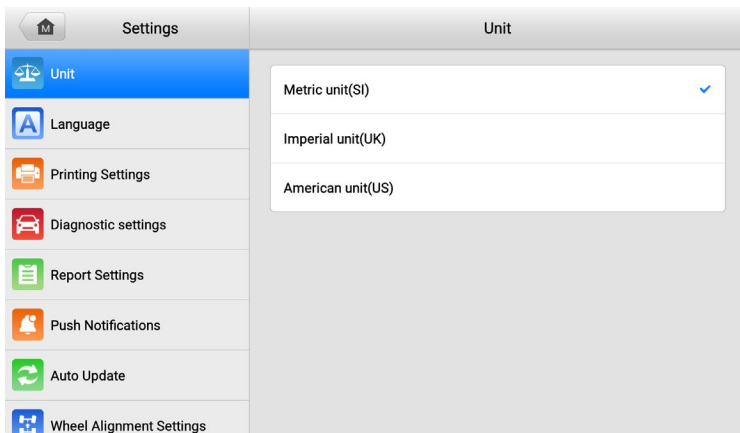

Figure 4-1 Unit Screen

4.2 Language

This option allows you to adjust the display language for the MaxiSys system.

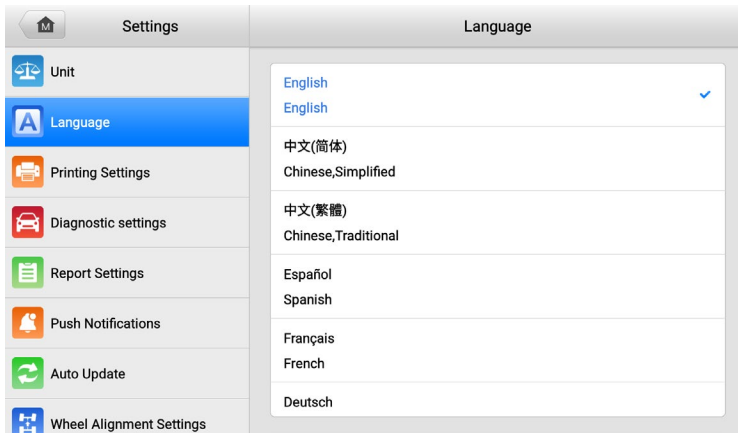

Figure 4-2 Language Screen

4.3 Printing Settings

Configure this option to enable the tablet to print via the network.

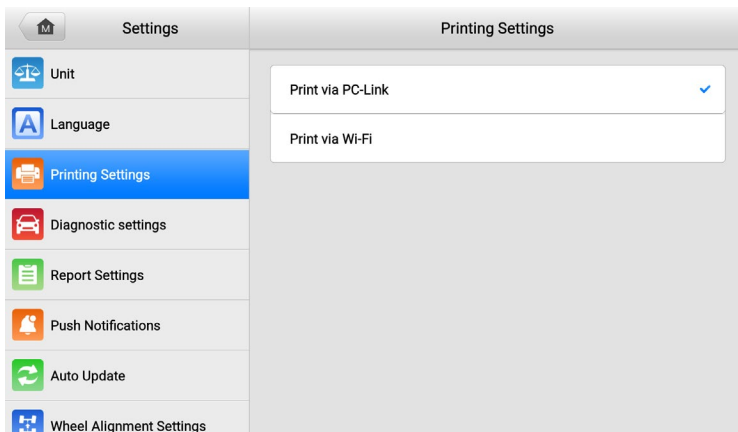

Figure 4-3 Printing Settings Screen

Printing operations involve installing the MaxiSys Printer driver to receive files from the MaxiSys tablet and execute printing tasks via the PC.

➤ **To install the MaxiSys Printer driver**

1. Download **Maxi PC Suite** from www.autel.com > Support > Downloads > Autel Update Tools, and install it on a Windows-based PC.
2. Double click **Setup.exe**.
3. Select the installation language, and the wizard will load momentarily.
4. Follow the instructions on the screen and click **Next** to continue.
5. Click **Install**, and the printer driver program will be installed onto the computer.
6. Click **Finish** to complete the installation. Then the MaxiSys printer runs automatically.

🔗 **NOTE**

1. Before printing, make sure the tablet is connected to the same network as your PC, either via Wi-Fi or LAN.
 2. Make sure the PC with the Printing Services program installed is connected to a printer.
-

➤ **To print a file using the PC**

1. Run the **PC Link** program on the PC. Select the **MaxiSys Printer** tab.
2. Click **Test Print** to check whether the printer works properly.
3. Tap the **Print** button on the toolbar of the tablet. A test document will be sent to the PC.
 - If the **Auto Print** option in the MaxiSys Printer is selected, the MaxiSys Printer will automatically print the received document.
 - If the **Auto Print** option is not selected, click **Open PDF File** to view all the temporary files. Select the file(s) needed for printing, and tap **Print**.

4.4 Diagnostic Settings

This setting allows you to enable or disable the diagnostic function. When enabled, the Diagnostics application is displayed on the MaxiSys Job Menu; otherwise, it is hidden.

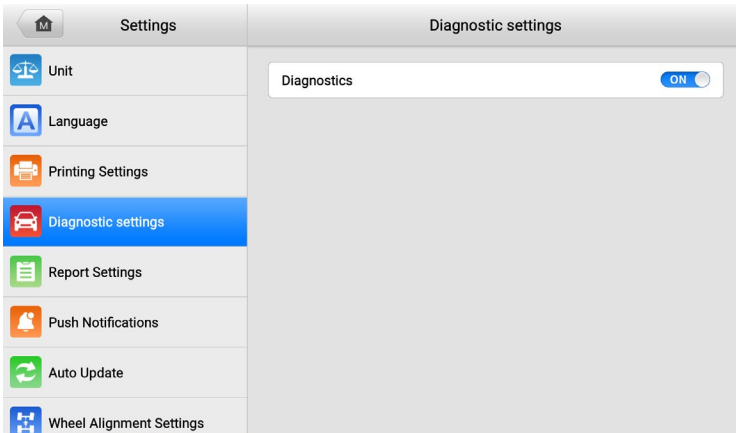

Figure 4-4 Diagnostic Settings Screen

4.5 Report Settings

The options, such as Scan Report, Report Upload to Cloud, OBD Ready Status, and Insurance Information, are available in the Report Settings function.

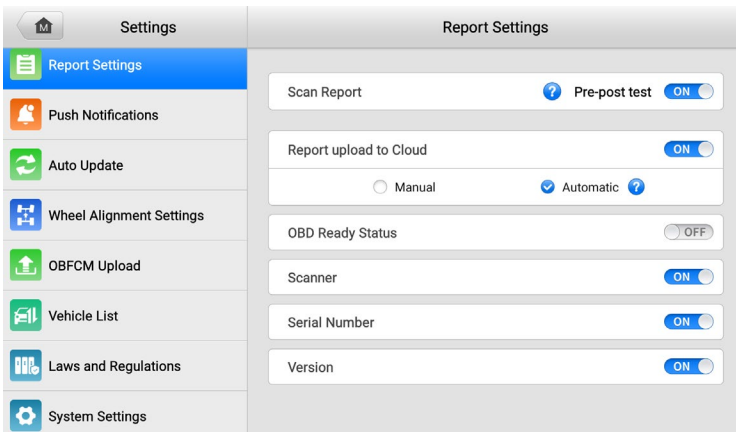

Figure 4-5 Report Settings Screen

- Scan Report

When enabling the function, you can compare changes between the pre-scan and post-scan. See [Pre-Scan and Post-Scan Functions](#) for details.

- Report Upload to Cloud

This setting allows you to enable or disable Report Upload to Cloud and to select Manual or Automatic mode. This mode synchronizes vehicle diagnostic information with vehicle history and generates a diagnostic report for upload. See [Diagnostics Report Cloud Sharing](#) for details.

NOTE

Make sure the tablet is connected to a network while uploading reports.

- OBD Ready Status

This setting is disabled by default. The OBD ready status will be automatically read in the Auto Scan function once the OBD Ready Status button is enabled.

- Scanner, Serial Number, and Version

When enabling the function, device information, including the name, serial number, and version, will be displayed in the report.

4.6 Push Notifications

This option allows you to manage notifications. Notification Preferences are enabled by default and cannot be disabled by users, ensuring that critical system notifications (such as security warnings) are not blocked. For other notifications, tap the  button to select your desired notification frequency and status.

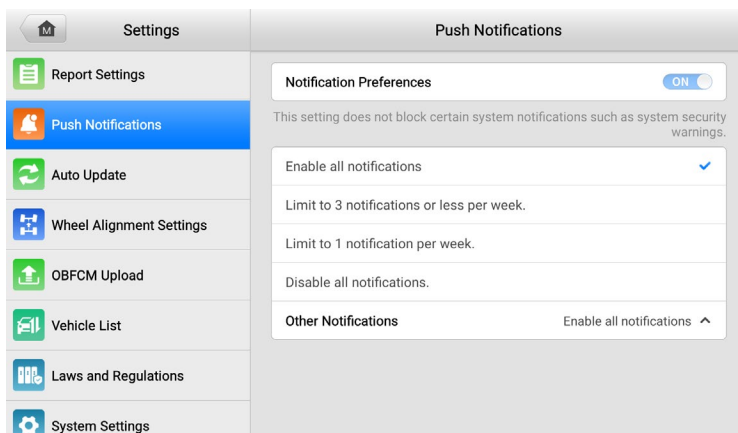

Figure 4-6 Push Notifications Screen

NOTE

- Notifications will display on the screen. Slide the screen from the top to check the received messages. If the message list covers more than one screen, slide the list up or down to view them.
 - Tapping a specific message launches the corresponding application. For example, if you tap an Update notification, the Update application will be launched.
-

4.7 Auto Update

The Auto Update allows the tool to automatically update the OS, the MaxiSys system, and the vehicle coverage software. Each can be configured to update automatically at a specified time.

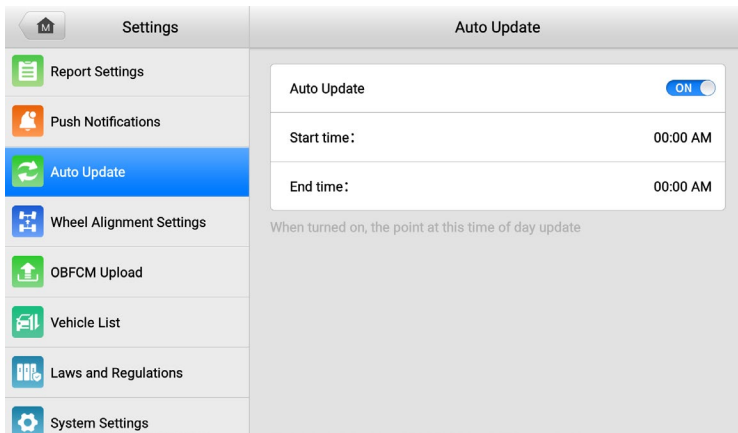

Figure 4-7 Auto Update Screen

4.8 Wheel Alignment Settings

Before performing wheel alignment, carry out the necessary related settings to ensure the process runs smoothly.

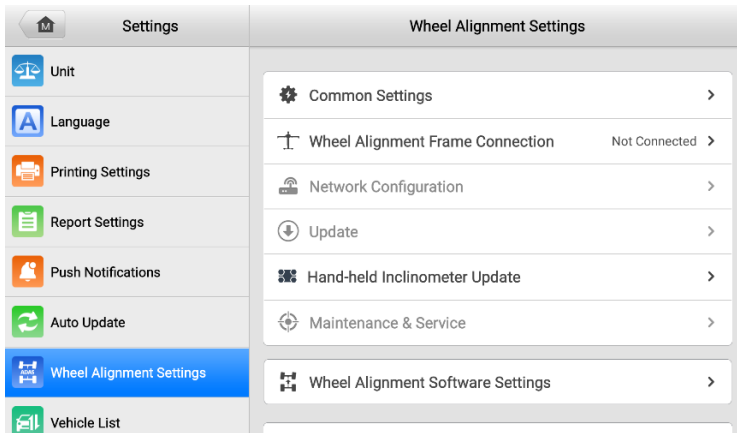

Figure 4-8 Wheel Alignment Settings Screen

4.8.1 Common Settings

Common settings include Unit Settings, Graphical Result Display Setting, Select Clamp Type, Connect Tread Measuring Tool, Select Tire Pressure Measuring Device, Select Height Measuring Tool, Mercedes Chassis Level Measuring Tool, and Beep Setting.

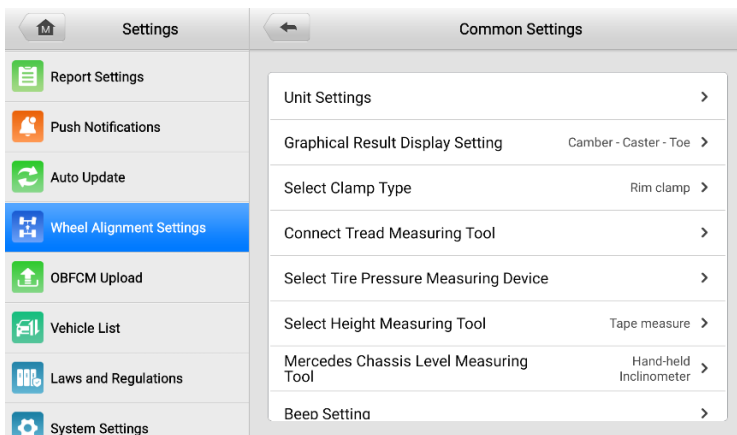

Figure 4-9 Common Settings Screen

4.8.1.1 Unit Settings

In Unit Settings, you can switch the display format and unit of the standard values and

measured values.

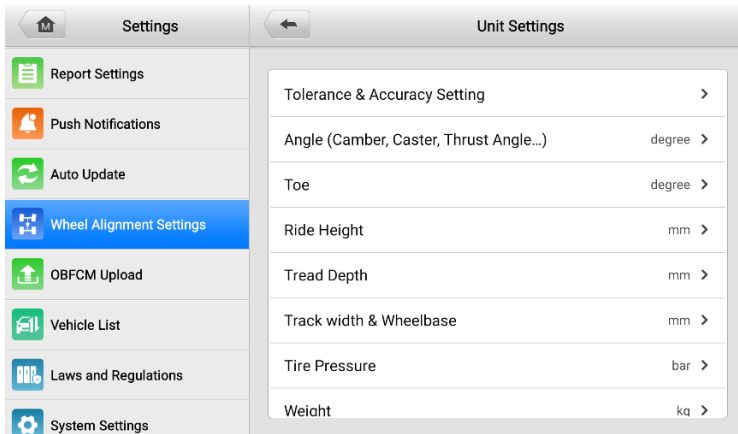

Figure 4-10 Unit Settings Screen

4.8.1.2 Graphical Result Display Setting

This setting allows you to switch the layout of the measured results in the wheel alignment function.

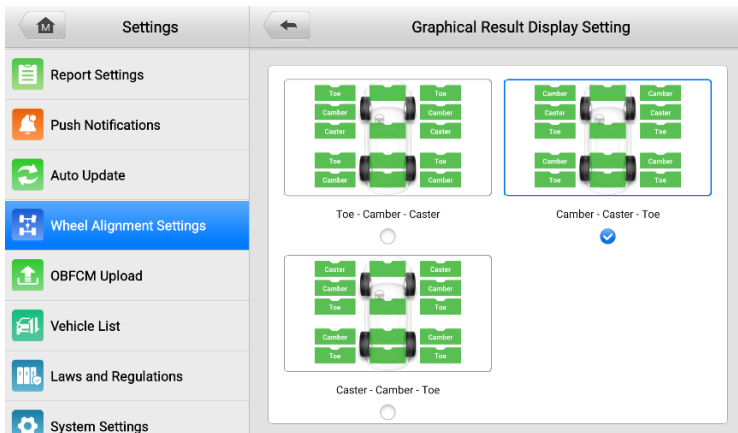

Figure 4-11 Graphical Result Display Setting Screen

4.8.1.3 Select Clamp Type

Select a compensation clamp type (rim clamp or tire clamp), and the tablet will guide you with the corresponding wheel alignment operation.

NOTE

Rim clamp is selected by default.

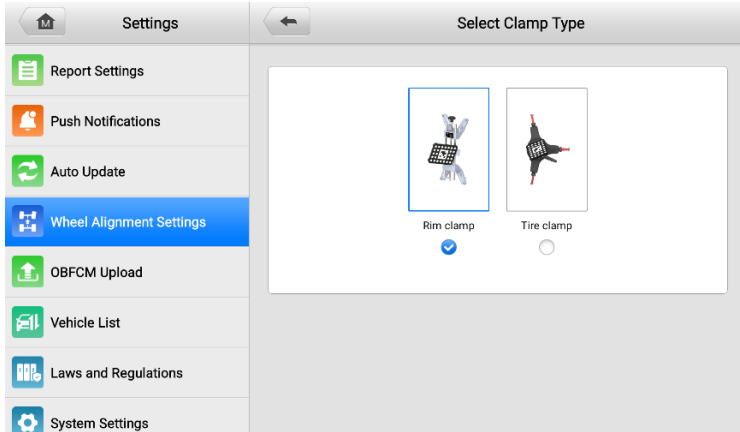

Figure 4-12 Select Clamp Type Screen

4.8.1.4 Connect Tread Measuring Tool

This setting enables you to connect the TBE device for measuring tread.

➤ **To connect the MaxiTPMS TBE Device**

1. Tap **Common Settings**, and select **Connect Tread Measuring Tool**.
2. Tap the **ON/OFF** button on the right side of the screen to search for available device(s).
3. Follow the screen guides to connect the TBE device and the tablet to the same Wi-Fi.

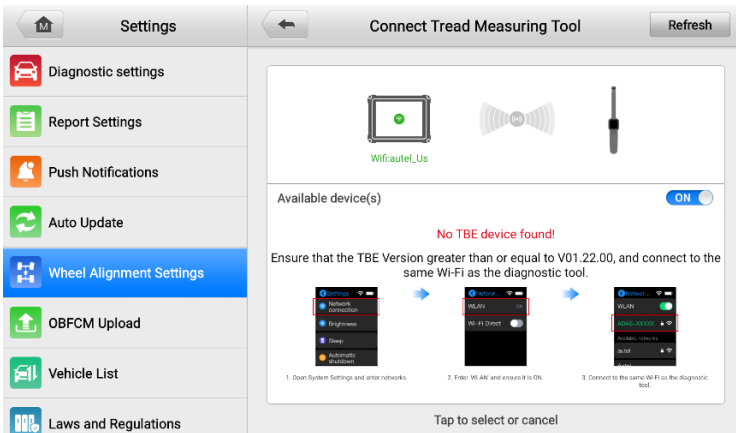

Figure 4-13 Connect Tread Measuring Tool Screen

4. After the TBE device and the tablet are connected to the same Wi-Fi, tap the desired device in the available devices list. Once the MaxiTPMS TBE device is connected, the connection status displays as “Paired.”

4.8.1.5 Select Tire Pressure Measuring Device

This setting enables you to connect the ITS600 device for measuring tire pressure.

➤ To connect the ITS600 Device

1. Tap **Common Settings**, and tap **Select Tire Pressure Measuring Device**.
2. Tap the **ON/OFF** button on the right side of the screen to search for available device(s).
3. Follow the screen guides to connect the ITS600 device and the tablet to the same Wi-Fi.

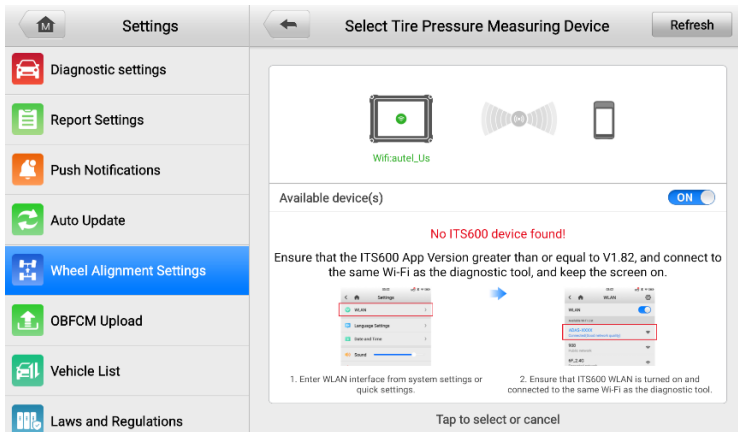

Figure 4-14 Connect Tire Pressure Measuring Device Screen

4. After the ITS600 device and the tablet are connected to the same Wi-Fi, tap the desired device in the available devices list to connect. Once the ITS600 device is connected, the connection status displays as “Paired.”

4.8.1.6 Select Height Measuring Tool

This section allows you to select a ride height measuring tool (tape measure or ride height target). Selecting the tape measure option requires manual measurement and value input as guided; selecting the ride height target option enables automatic crossbar adjustment, target detection, and ride height calculation and display. For details, refer to [Ride Height Measurement](#).

NOTE

Tape measure is selected by default.

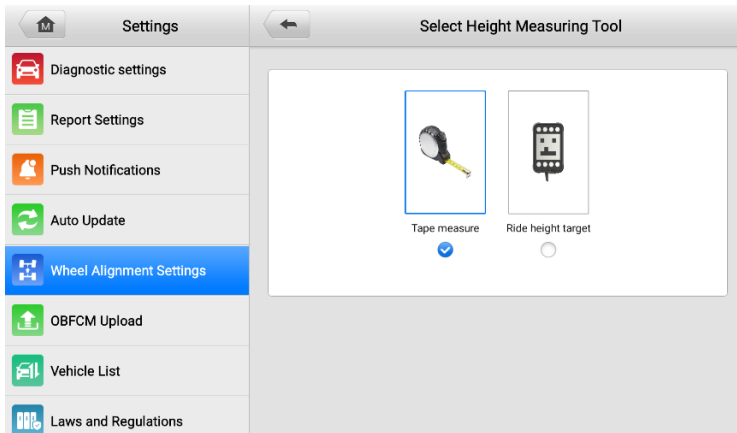

Figure 4-15 Select Height Measuring Tool Screen

4.8.1.7 Mercedes Chassis Level Measuring Tool

Mercedes vehicles require vehicle height measurement. Failure to measure the vehicle height will result in no available specification value. You can select Autel hand-held inclinometer or other tools to measure the vehicle height.

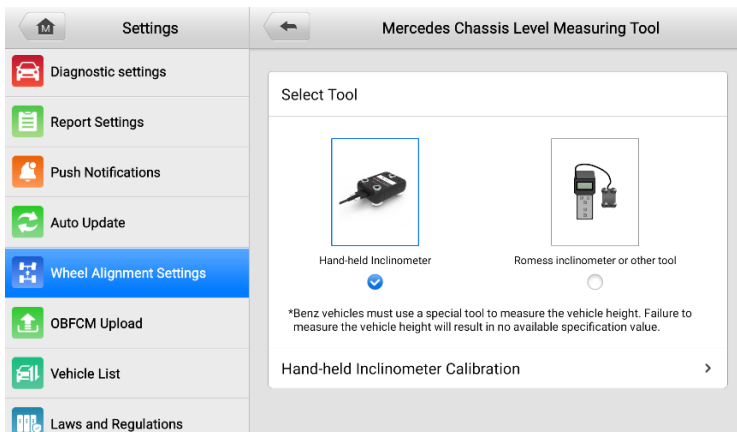

Figure 4-16 Select Mercedes Chassis Level Measuring Tool Screen

If the hand-held inclinometer provides inaccurate measurements after being dropped, tap **Hand-held Inclinometer Calibration** to recalibrate it.

➤ **To perform a hand-held inclinometer calibration**

1. Place the hand-held inclinometer on a flat and level surface.



Figure 4-17 Perform Hand-held Inclinometer Calibration 1

2. Turn the hand-held inclinometer 180°.



Figure 4-18 Perform Hand-held Inclinometer Calibration 2

3. Roll the hand-held inclinometer 180°.



Figure 4-19 Perform Hand-held Inclinometer Calibration 3

4. Turn the hand-held inclinometer 180°. Then the calibration is completed.



Figure 4-20 Perform Hand-held Inclinometer Calibration 4

4.8.1.8 Beep Setting

This setting allows you to enable or disable the beep when performing rolling compensation, lifting compensation, and Caster/SAI measurement.

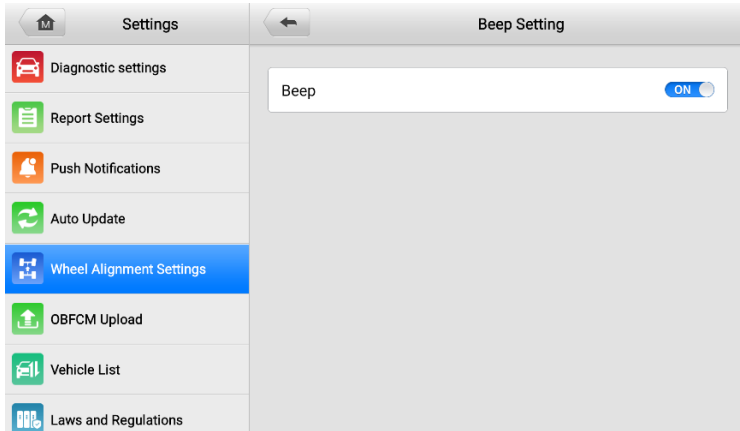

Figure 4-21 *Beep Setting Screen*

4.8.2 Wheel Alignment Frame Connection

Connect the tablet to the wheel alignment frame via the IWA500 Wi-Fi to establish communication.

NOTE

Before connecting the wheel alignment frame, check the Country/Region Settings in the Android system of the tablet.

➤ To connect the tablet to the wheel alignment frame

1. Turn on the tablet. Tap the **Settings** application on the Job Menu.
2. Tap **Wheel Alignment Settings** in the left column.
3. Select **Wheel Alignment Frame Connection** to enter the screen.

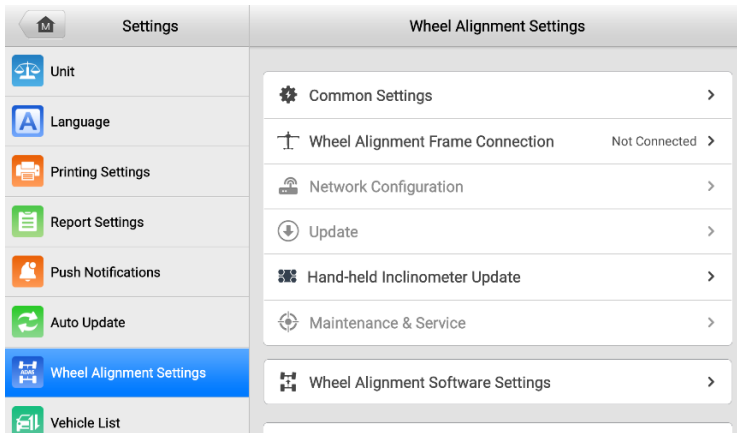

Figure 4-22 Connect IWA500 via Wi-Fi 1

4. Tap the Wi-Fi toggle switch to enable Wheel Alignment Wi-Fi. The tablet will search for available units. The Wi-Fi name of the frame will be "ADAS", followed by a serial number. Tap the appropriate unit to connect. When a connection is established, the connection status reads "Connected".

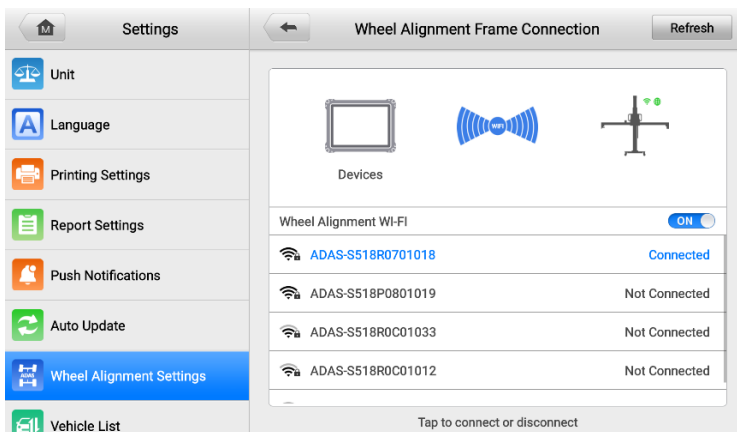

Figure 4-23 Connect IWA500 via Wi-Fi 2

NOTE

It may take up to 30 seconds to connect the tablet to a wheel alignment frame. Please wait patiently.

4.8.3 Network Configuration

Connect the tablet to an Internet-accessible Wi-Fi through the following settings.

➤ **To connect the tablet to the Internet Accessible Wi-Fi**

1. Tap the **Settings** application on the Job Menu.
2. Tap **Wheel Alignment Settings** in the left column.
3. Tap **Network Configuration** (ensure the IWA500 Wi-Fi is connected, or it will not be activated).

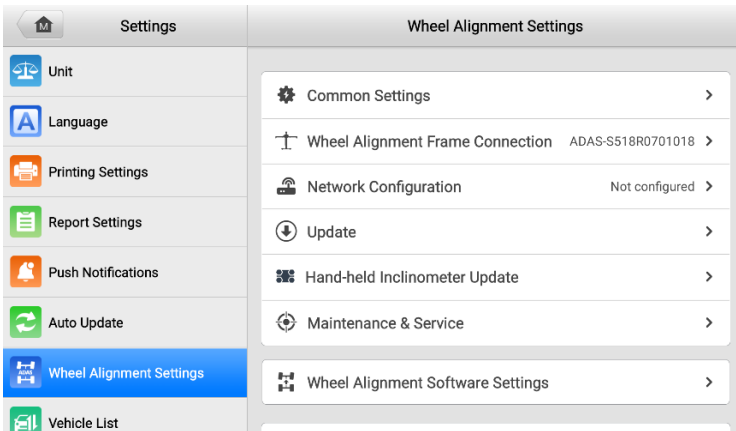

Figure 4-24 Connect to Internet Accessible Wi-Fi 1

4. Tap the drop-down button on the right side of the Wi-Fi name display box to select the Wi-Fi network, and then enter the Wi-Fi password.

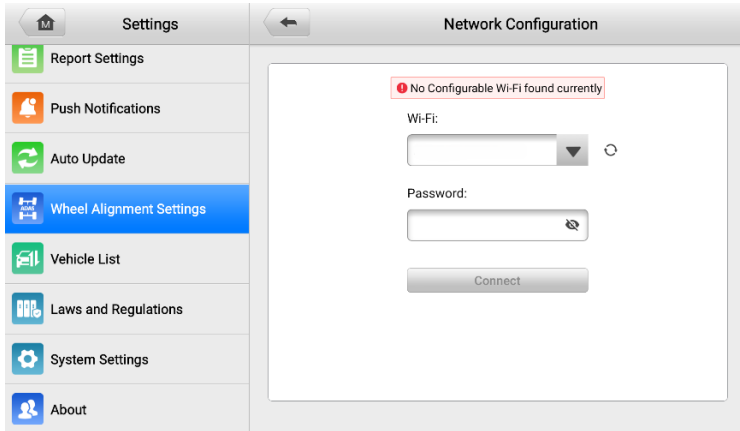

Figure 4-25 Connect to Internet Accessible Wi-Fi 2

5. Tap **Connect** to connect to the selected Wi-Fi network. Once connected successfully, a confirmation message will appear.

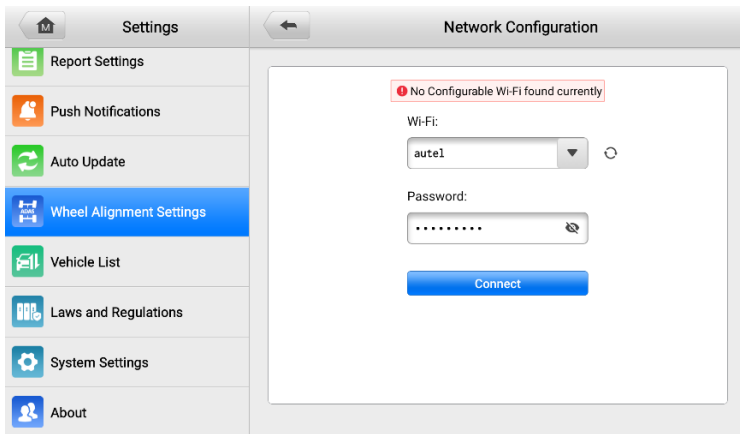

Figure 4-26 Connect to Internet Accessible Wi-Fi 3

4.8.4 Update

After the wheel alignment frame is connected and the network is configured, tap **Update** from **Wheel Alignment Settings** to update the frame.

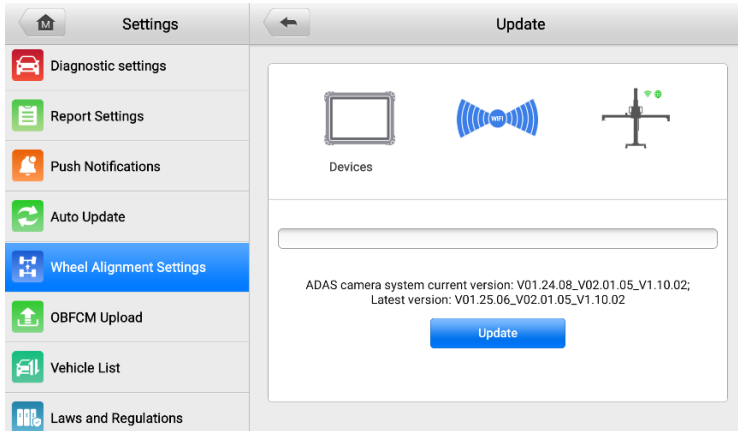

Figure 4-27 Update Screen

4.8.5 Hand-held Inclinometer Update

Connect the hand-held inclinometer to the tablet to update the device.

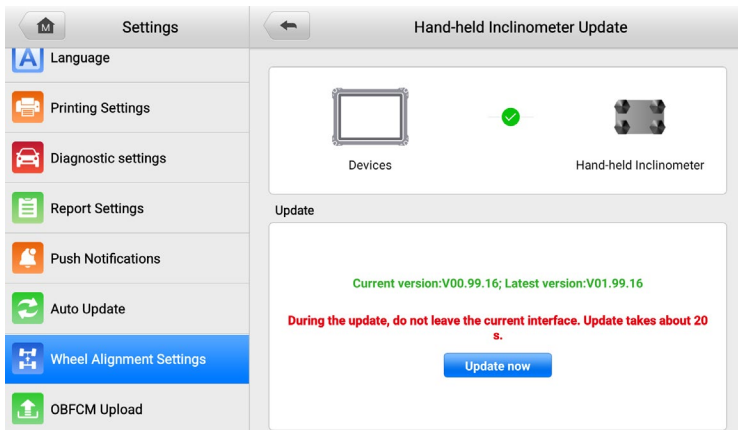

Figure 4-28 Hand-held Inclinometer Update Screen

4.8.6 Maintenance & Service

This section covers Calibration & Inspection, Calibration Record Report, Accuracy Check Interval, and Target Cleaning Interval.

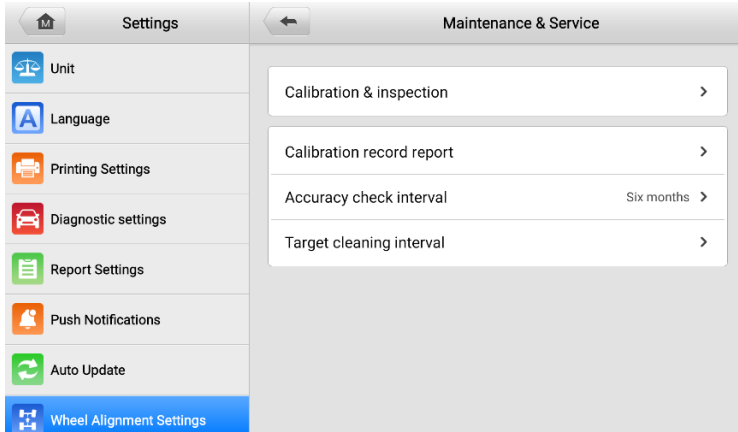

Figure 4-29 Maintenance & Service Screen

NOTE

Ensure the wheel alignment frame Wi-Fi is connected; otherwise, the maintenance & service function cannot be activated.

4.8.6.1 Calibration & Inspection

This section includes six items: Aligner Calibration, Wheel Clamp Target Calibration, Aligner Accuracy Check, Camera Check, Hardware Check, and Version Information.

NOTE

To perform Aligner Calibration, Wheel Clamp Target Calibration, and Aligner Accuracy Check, a calibration bar (AUTEL-CSC0500/10; AUTEL-CSC0500/12) is required. Contact your local dealer or manufacturer for purchase.

Aligner Calibration

The aligner needs to be calibrated when:

1. The camera has been disassembled.
2. The accuracy check has failed.

➤ **To calibrate the aligner**

1. Tap **Maintenance & Service**, and then select **Calibration & inspection > Aligner calibration**.
2. Place the calibration bar about 2.2 m in front of the wheel alignment frame. Install the front wheel targets on the calibration bar, align the location pin with the locating hole, and tighten the nut.

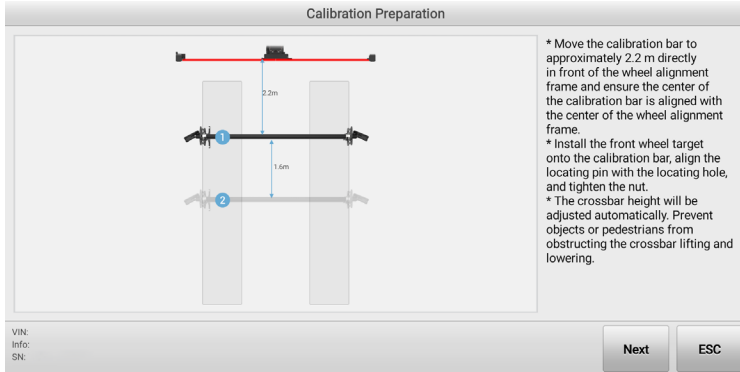

Figure 4-30 Aligner Calibration Preparation

3. Tap **Next**, and the crossbar height will adjust automatically to search for the target. Then follow the screen guide to move the calibration bar so that the values of 'Offset', 'L-Distance', and 'Distance Diff' are displayed in green.



Figure 4-31 Aligner Calibration 1

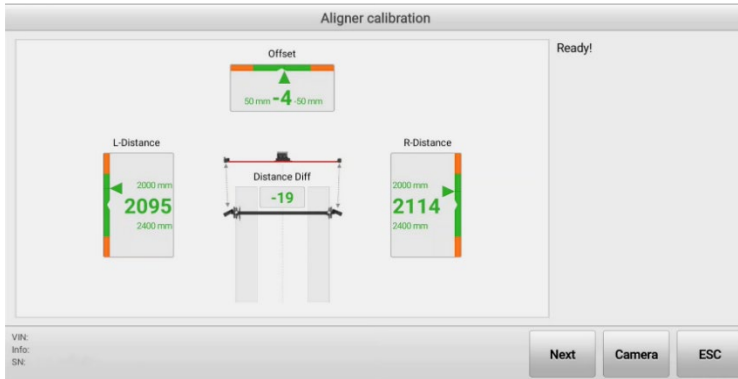

Figure 4-32 Aligner Calibration 2

4. Tap **Next** to enter the following screen. Rotate the calibration bar according to the screen prompts to collect data. When the arrows and the indicated block images turn green, stop rotating the crossbar.

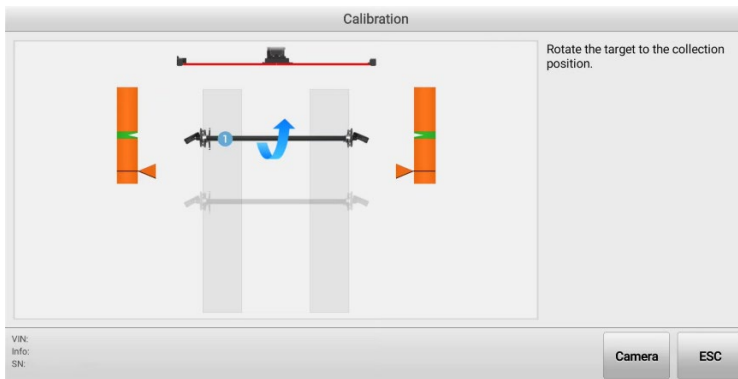

Figure 4-33 Calibration 1

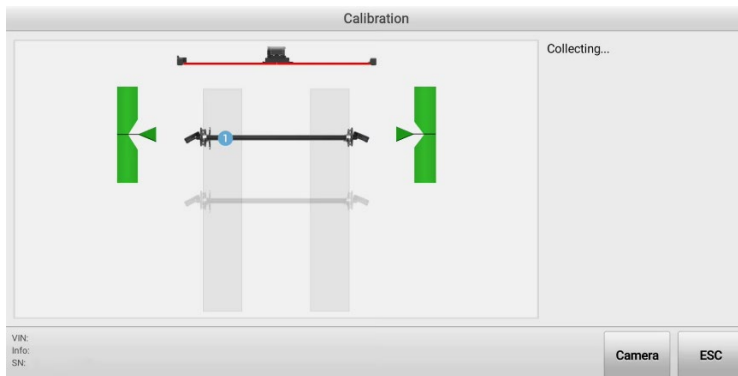

Figure 4-34 Calibration 2

5. Then place the calibration bar about 3.8 m in front of the wheel alignment frame and complete the calibration steps as shown in the screen guides to collect the corresponding data.

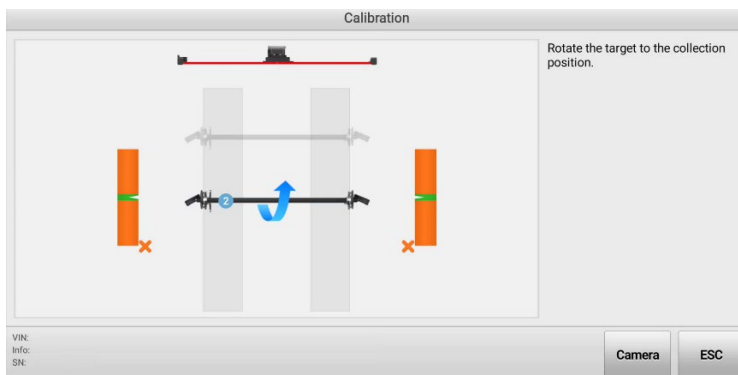

Figure 4-35 Calibration 3

6. After the data of the front wheel targets are collected, remove the targets from the calibration bar, and install the rear wheel targets on the calibration bar. Complete the calibration steps as shown in the screen guides.

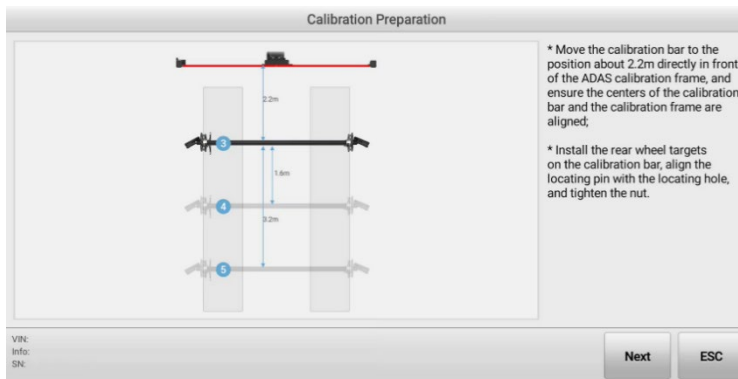

Figure 4-36 Calibration 4

- After the data of the four targets are collected, the calibration result screen will be displayed. indicates a successful calibration; while indicates a failed calibration that requires recalibration.

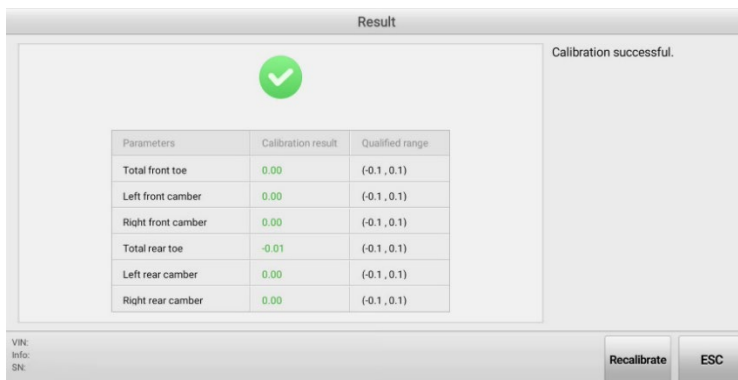

Figure 4-37 Calibration Result Screen

Wheel Clamp Target Calibration

When the matching wheel clamp (rim clamp/tire clamp) or the target has been replaced, the newly assembled wheel clamp (rim clamp/tire clamp) or target needs to be recalibrated.

NOTE

The illustrations of clamps in this manual are based on rim clamps.

1. Use Calibration Bar

- **To calibrate the wheel clamp (rim clamp) and target using the calibration bar**
 1. Tap **Maintenance & Service**, and then select **Calibration & inspection > Wheel clamp target calibration**.
 2. Select **Wheel clamp target calibration — with calibration bar**.

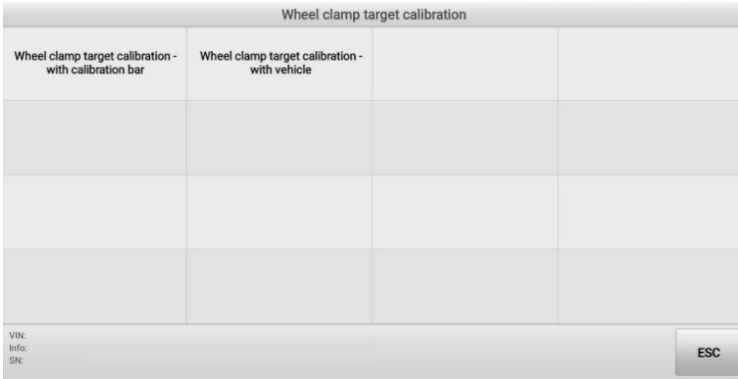

Figure 4-38 Select Calibration Method

3. Then select the target that needs to be calibrated. The Right Rear Wheel Target (properly installed on the right rear rim clamp) is used for illustration.



Figure 4-39 Select Target for Calibration

4. The tablet will automatically display the calibration preparations. Follow the screen guides to move the calibration bar to a position about 2.2 m directly in front of the wheel alignment frame. Then install the right-rear wheel clamp (rim clamp) and the right-rear target on the calibration bar, align the locating pin with the locating hole, and tighten the nut.

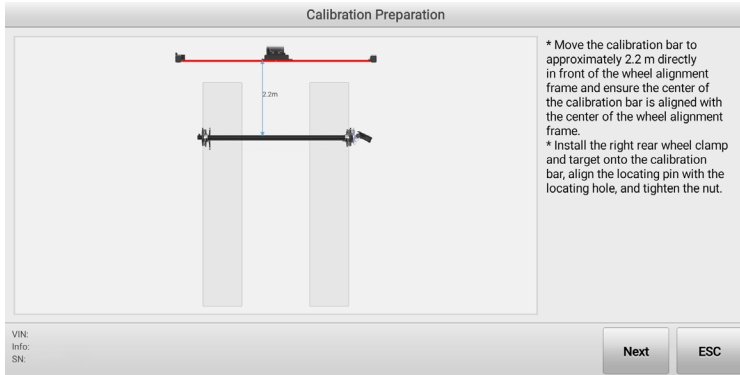

Figure 4-40 Calibration Preparation (Use Calibration Bar)

5. Tap **Next** when the distance is adjusted to the required range, and the tablet will indicate that it is ready for subsequent operations.



Figure 4-41 Start Calibration (Use Calibration Bar) 1

6. Tap **Next** to continue. Follow the screen guide to rotate the calibration bar so that the targets are in the collection position.

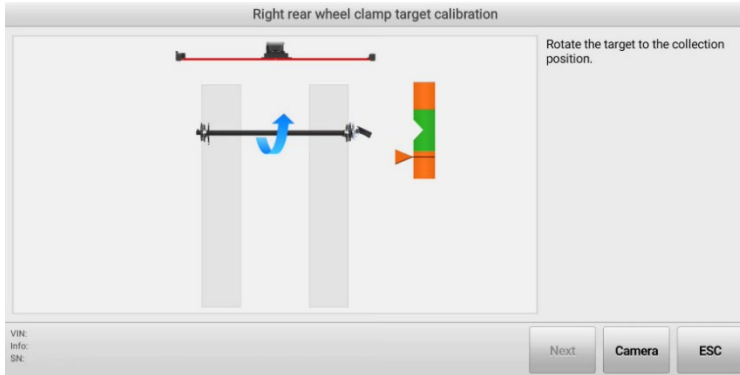

Figure 4-42 Start Calibration (Use Calibration Bar) 2

7. When the arrows and the indicated block images turn green, stop rotating the crossbar, and the tablet will start data collecting automatically.

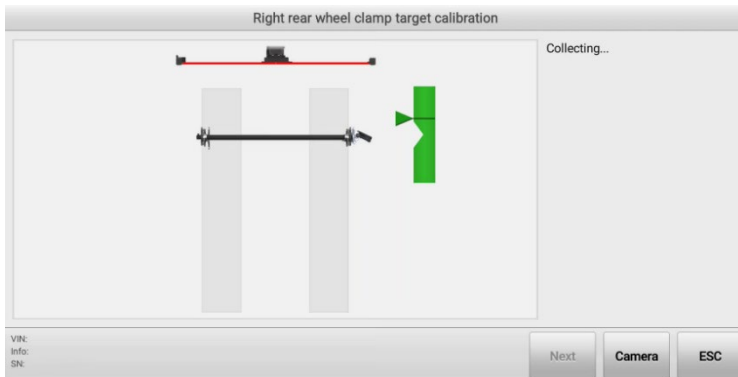

Figure 4-43 Start Calibration (Use Calibration Bar) 3



8. After data collection, the calibration result screen will be displayed.  indicates a successful calibration, and you can tap **ESC** to exit the function; while  indicates a failed calibration, and you can tap **Recalibrate** to calibrate again.



Figure 4-44 Calibration Result Screen

2. Use Vehicle

➤ To calibrate the wheel clamp (rim clamp) and target using the vehicle

1. Tap **Maintenance & Service**, and then select **Calibration & inspection** > **Wheel clamp target calibration**.
2. Select **Wheel clamp target calibration — with vehicle**. Refer to [Figure 4-38 Select Calibration Method](#) for details.
3. Then select the target that needs to be calibrated. The Right Front Wheel Target (properly installed on the right front rim clamp) is used for illustration. Refer to [Figure 4-39 Select Target for Calibration](#) for details.
4. As shown in the screen guides, drive the vehicle onto the lift, steer ahead, lock the steering wheel holder stand tool, place the transmission in neutral, and release the parking brake. Then install the right front wheel clamp on the right front wheel, and raise the front axle.

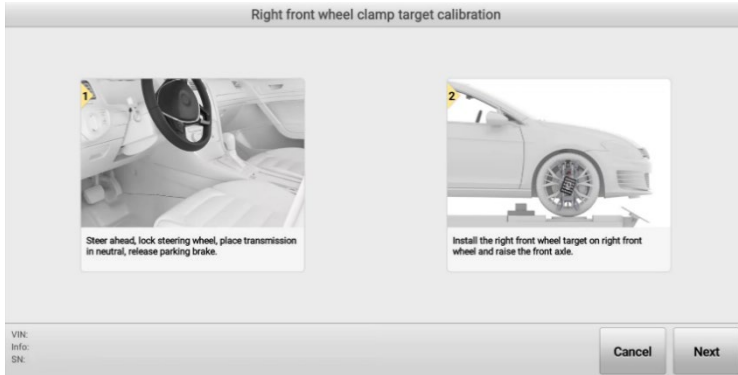

Figure 4-45 Calibration Preparation (Use Vehicle) 1

5. Tap **Next** to continue. Follow the screen guides to place the wheel alignment frame about 2.2 m from the center of the front wheel, and ensure that the centers of the frame and the vehicle are aligned. Then press the **UP** and **DOWN** buttons on the back of the frame to adjust the crossbar height so that the crossbar is roughly at the same height as the center of the front wheel.

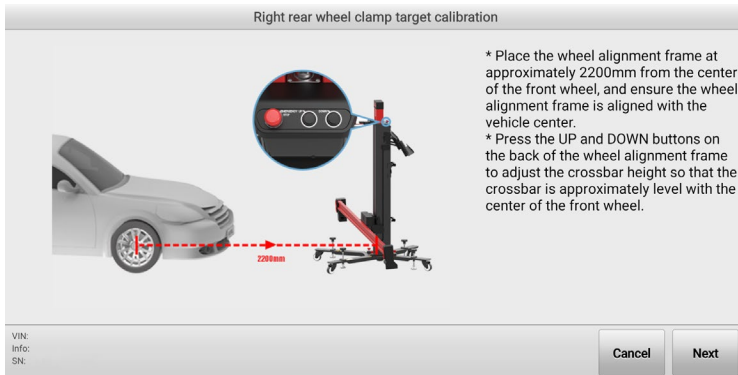

Figure 4-46 Calibration Preparation (Use Vehicle) 2

6. Tap **Next** when the distance is adjusted to the required range, and the tablet will indicate that it is ready for subsequent operations.



Figure 4-47 Calibration Preparation (Use Vehicle) 3

7. Rotate the wheel as shown in the screen guides.

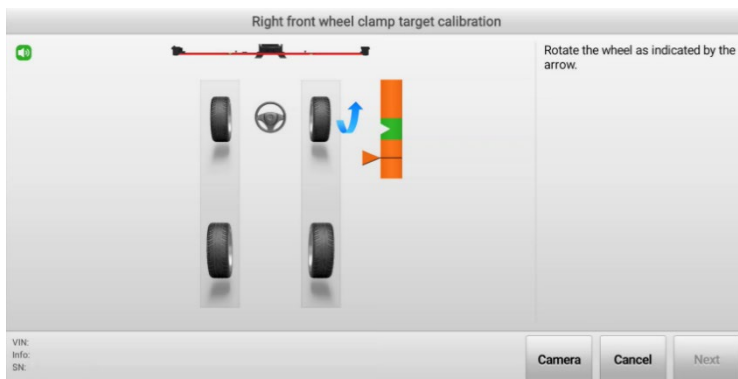

Figure 4-48 Start Calibration (Use Vehicle) 1

8. When the arrows and the indicated block images turn green, stop turning the wheel, and the tablet will start data collecting automatically.

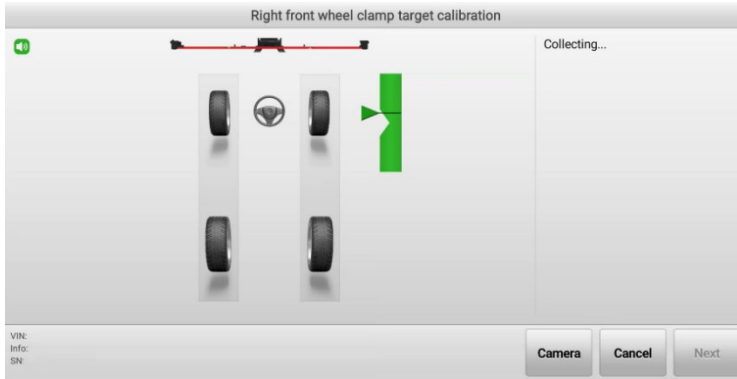

Figure 4-49 Start Calibration (Use Vehicle) 2



9. After data collection, the calibration result screen will be displayed.  indicates a successful calibration, and you can tap **ESC** to exit the function; while  indicates a failed calibration, and you can tap **Recalibrate** to calibrate again.



Figure 4-50 Calibration Result Screen (Use Vehicle)

Aligner Accuracy Check

Aligner accuracy check is recommended when:

1. The aligner suffered a high-intensity collision.

2. The accuracy check has not been performed for more than six months.

The software provides three types of accuracy check methods: Aligner Accuracy Check using Calibration Bar, Aligner Accuracy Check using Vehicle, and Quick Accuracy Check.

1. Use the Calibration Bar

An accuracy check can be performed using a calibration bar, enabling the overall accuracy of the measurement system (comprising cameras, rim clamps, and targets) to be verified accurately and reliably.

➤ To perform an accuracy check with the calibration bar

1. Tap **Maintenance & Service**, and then select **Calibration & inspection > Aligner Accuracy Check**.
2. Select **Accuracy Check – with calibration bar**.
3. According to the screen guides, move the calibration bar to a position about 2.2 m directly in front of the wheel alignment frame. Install the front wheel clamps (rim clamps) and targets on the calibration bar, align the locating pin with the locating hole, and tighten the nut.

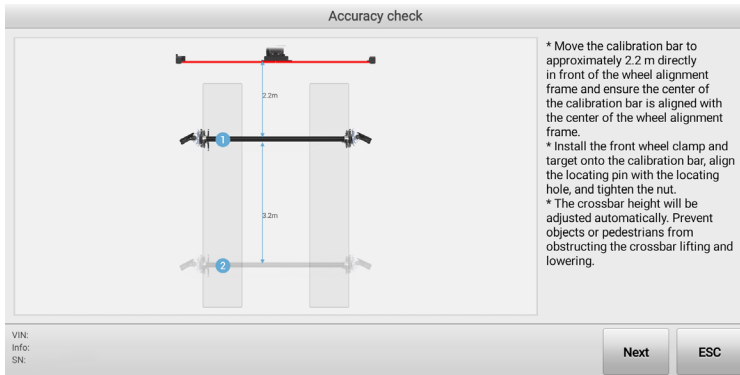

Figure 4-51 Accuracy Check (Use Calibration Bar) 1

4. Tap Next. The crossbar height will be adjusted automatically, and the system will proceed to the next screen. As shown in the screen guide, move the calibration bar so that the values of 'Offset', 'L-Distance', and 'Distance Diff' are displayed in green.

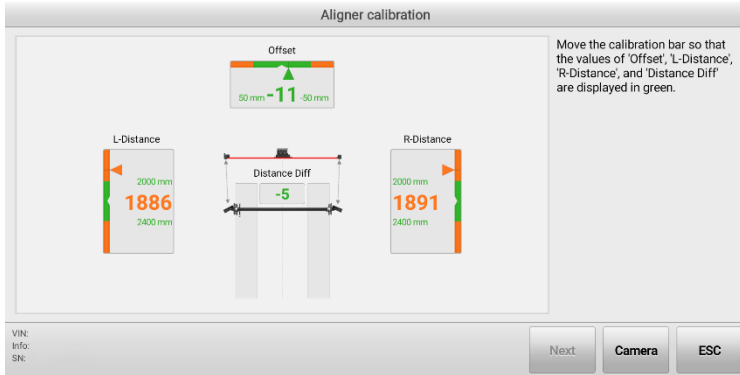

Figure 4-52 Accuracy Check (Use Calibration Bar) 2

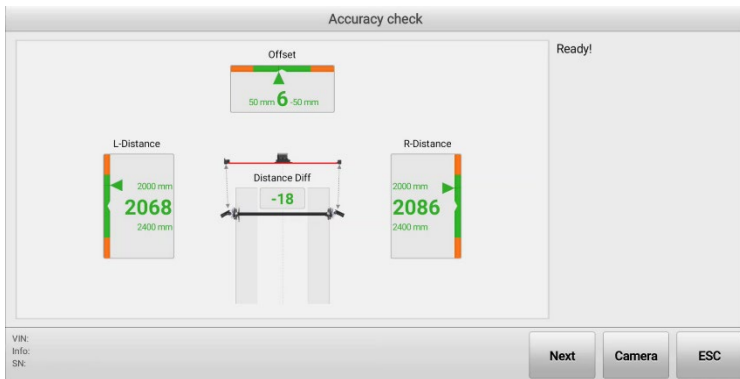

Figure 4-53 Accuracy Check (Use Calibration Bar) 3

5. Tap **Next** to enter the following screen. Rotate the calibration bar according to the screen prompts to collect data. When the arrows and the indicated block images turn green, stop rotating the calibration bar.

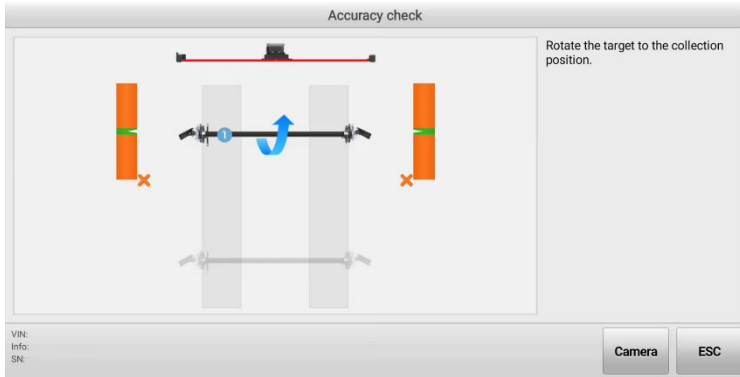

Figure 4-54 Accuracy Check (Use Calibration Bar) 4

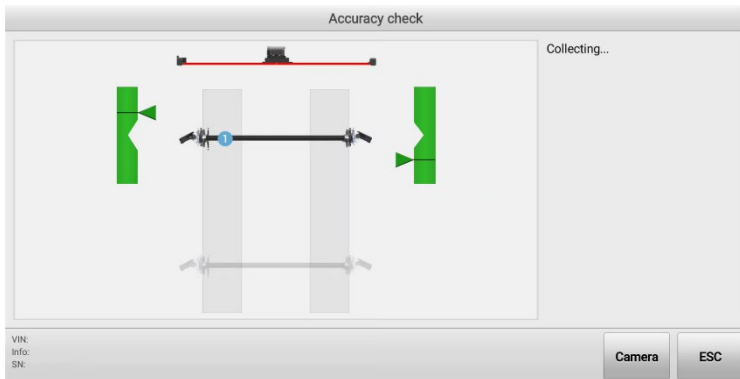

Figure 4-55 Accuracy Check (Use Calibration Bar) 5

6. Place the calibration bar about 5.4 m in front of the wheel alignment frame and complete the calibration steps as shown in the screen guides to collect the corresponding data.

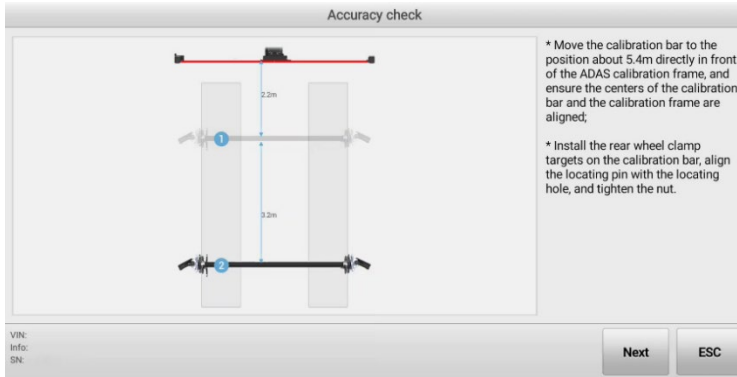

Figure 4-56 Accuracy Check (Use Calibration Bar) 6

- After data collection, the calibration result screen will be displayed. indicates a successful calibration, and you can tap **ESC** to exit the function; while indicates a failed calibration, and you can tap **Recheck** to calibrate again.

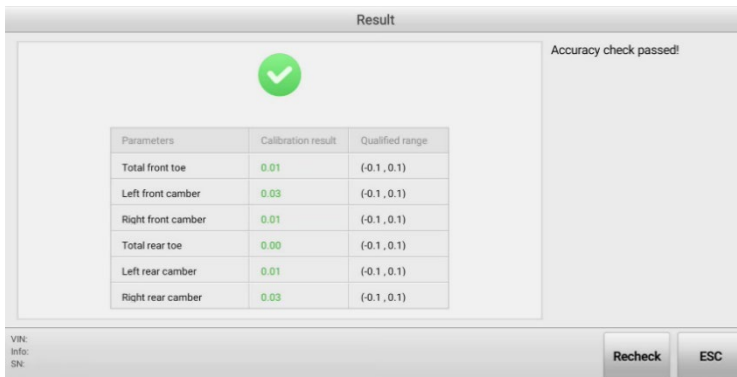

Figure 4-57 Accuracy Check Result Screen

2. Use the Vehicle

An accuracy check can be performed with a vehicle, allowing the overall accuracy of the measurement system (comprising cameras, rim clamps, and targets) to be verified without using a calibration bar. Since inspection accuracy is affected by vehicle condition, it is recommended to use a well-maintained sports vehicle for this check.

➤ **To perform an accuracy check with the vehicle**

1. Tap **Maintenance & Service**, and then select **Calibration & inspection > Aligner Accuracy Check**.
2. Select **Accuracy Check — with vehicle**.
3. Follow the screen guide to set the vehicle to the required status.

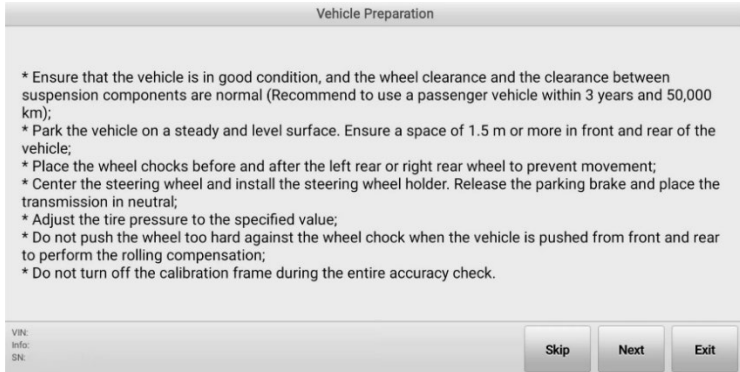

Figure 4-58 Vehicle Preparation

4. Tap **Next** and follow the guides shown on the screen to place the wheel alignment frame and install the wheel clamps (rim clamps) and target on the wheels properly.

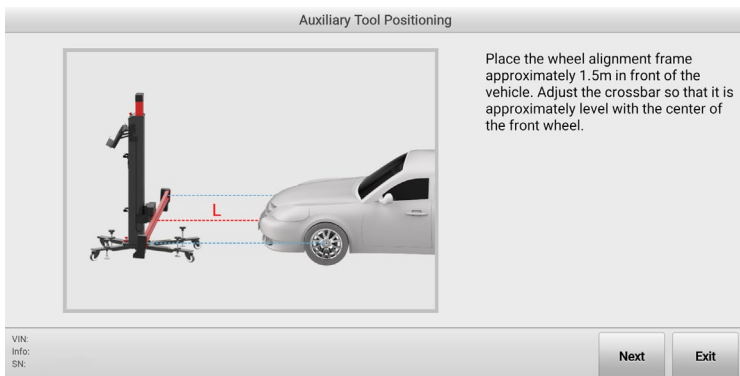

Figure 4-59 Auxiliary Tool Positioning 1

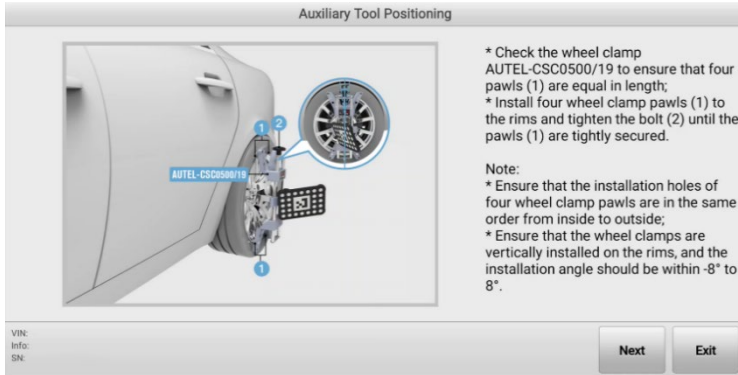

Figure 4-60 Auxiliary Tool Positioning 2

5. Tap **Next**. The crossbar will be adjusted automatically to search for the target, and the tablet will enter the following screen. Follow the screen guide to move the rear wheel chock backward for about 30 cm, and push the vehicle backward, so that the values are displayed green. When the arrows and indicated block images are displayed green, stop pushing the vehicle and wait for the tablet to enter the next screen.

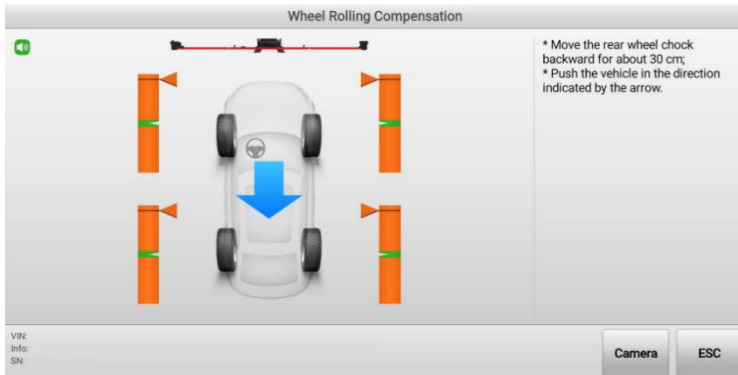

Figure 4-61 Wheel Rolling Compensation 1

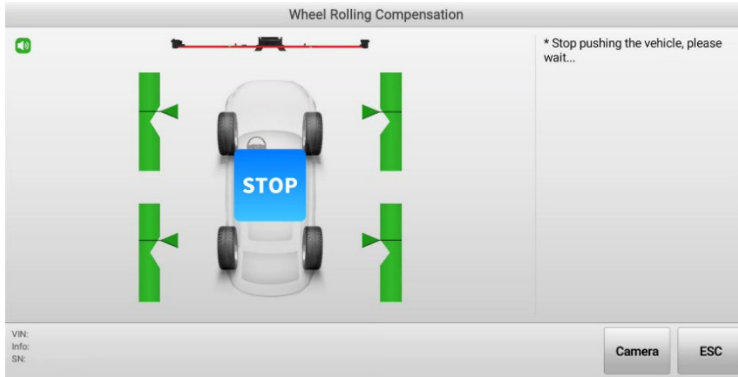

Figure 4-62 Wheel Rolling Compensation 2

6. Push the vehicle forward. When the arrows and indicated block images are displayed green, stop pushing the vehicle and wait for the tablet to enter the next screen.

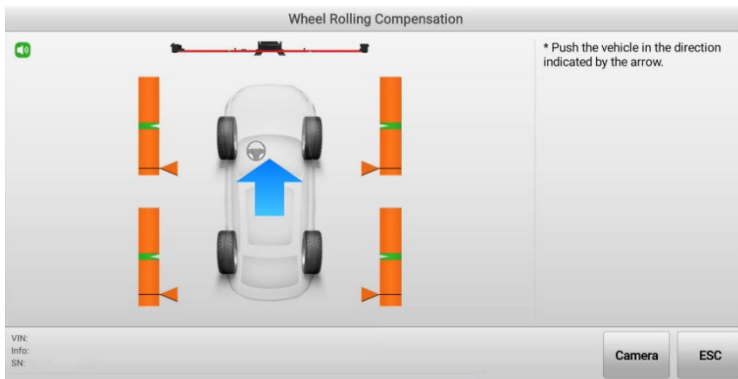

Figure 4-63 Wheel Rolling Compensation 3

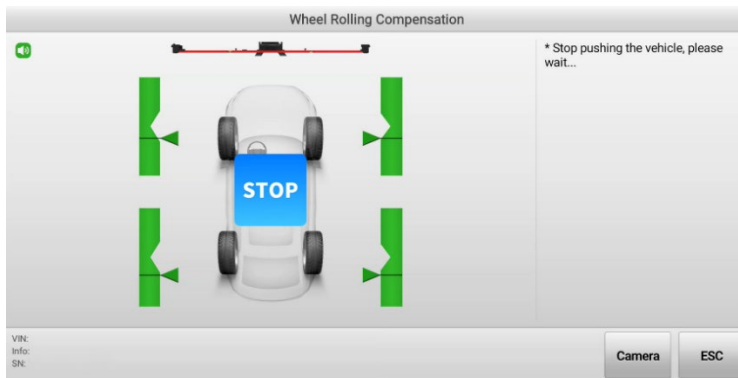



Figure 4-64 Wheel Rolling Compensation 4

7. Place the wheel alignment frame directly behind the rear of the vehicle, and follow the screen guides to complete the procedure.
8. After the operation is completed, the calibration result screen will be displayed.  indicates a successful calibration; while  indicates a failed calibration that requires recalibration.

3. Quick Accuracy Check

A quick accuracy check is performed automatically every six months by default. The accuracy check interval can be modified in the settings of the wheel alignment software. This check can detect faults in the measurement system consisting of cameras and targets, but does not cover wheel clamps.

➤ To perform a quick accuracy check

1. Tap **Maintenance & Service**, and then select **Calibration & inspection > Aligner Accuracy Check**.
2. Select **Quick accuracy check**.
3. Follow the screen guide to set the vehicle to the required status.

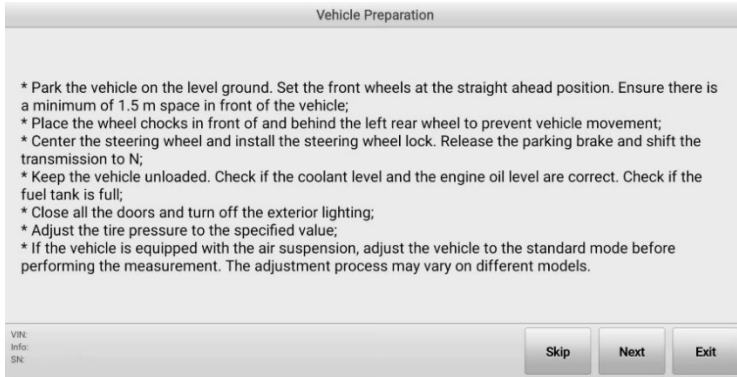

Figure 4-65 Vehicle Preparation

4. Tap **Next** and follow the guides shown on the screen to place the wheel alignment frame and install the wheel clamps (rim clamps) and target on the wheels properly.

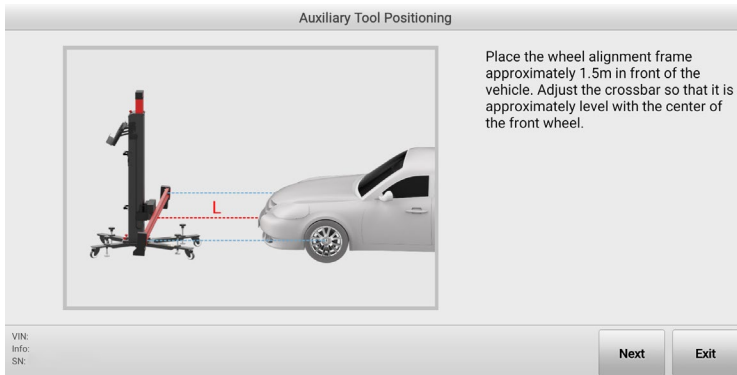

Figure 4-66 Auxiliary Tool Positioning 1

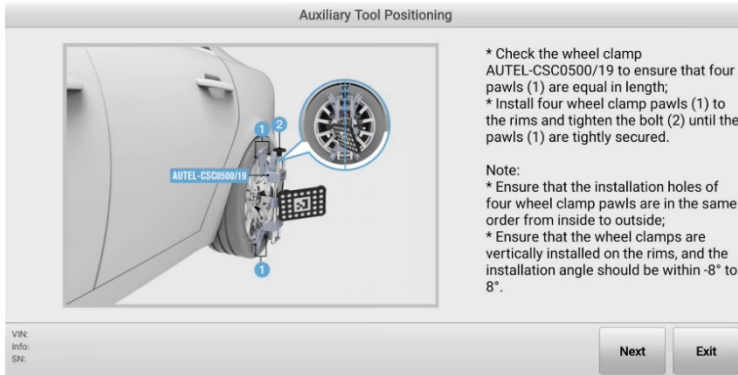

Figure 4-67 Auxiliary Tool Positioning 2

5. Then tap **Next**, the crossbar will be adjusted automatically to search for the target, and the tablet will enter the following screen.

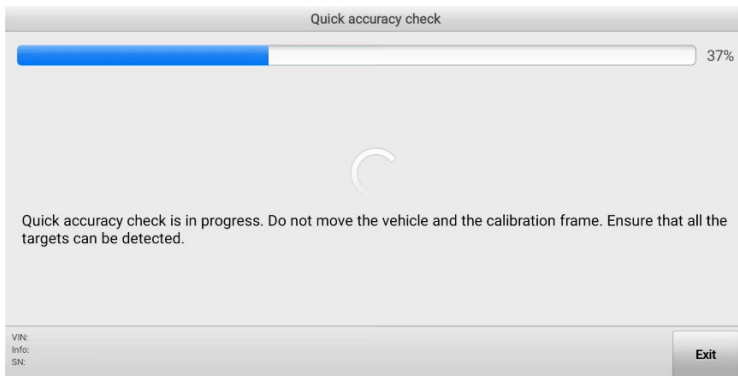



Figure 4-68 Quick Accuracy Check

6. The quick accuracy check result will be displayed after the check progress is completed.  indicates a successful calibration; while  indicates a failed calibration that requires recalibration.

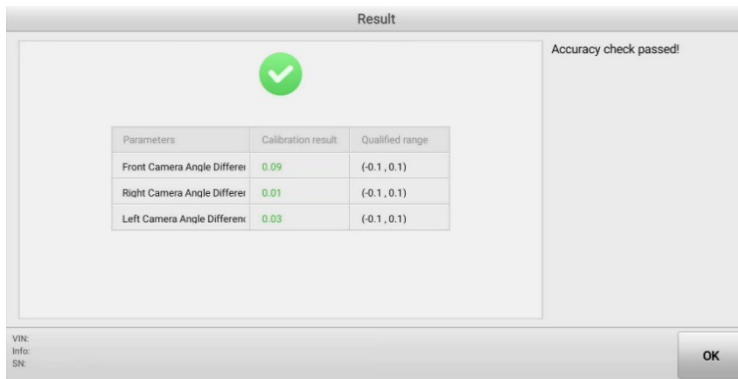

Figure 4-69 Quick Accuracy Check Result

Camera Check



The Camera Check function is performed to check the status of the five cameras on the wheel alignment frame.

➤ To perform camera check

1. Tap **Maintenance & Service**, then select **Camera check**. The views and status of the cameras, including the distance measuring camera, self-calibration camera, LF target camera, LR target camera, RF target camera, and RR target camera, will be displayed on the screen.
2. Tap **Description** to check the explanations for each icon displayed on the screen.

Table 4-1 Camera Descriptions

Icon	Name	Explanation
	Normal Target Dots	Target dots can be recognized normally.
	Abnormal Target/Target Dots	The target is dirty or blocked; clean it or remove the obstructions.
	Enabled Camera	The camera works normally.

Icon	Name	Explanation
	Not Enabled Camera	The camera is not used in the current function.
	Abnormal Camera	<p>The diagnostic tool fails to communicate with the cameras. Follow the steps below:</p> <ol style="list-style-type: none"> 1. Check if the power is ON; 2. Check if the current camera connection is normal; 3. Check if the diagnostic tool is connected to the camera Wi-Fi; 4. Record and upload logs. Fill in the problem description in detail.

Hardware Check

This section allows you to check the status of various components of the wheel alignment frame.

Version Information

This section allows you to check the version information of various components of the wheel alignment frame.

4.8.6.2 Calibration Record Report

All the calibration records are saved here; you can view when and what type of calibration the equipment has performed.

4.8.6.3 Accuracy Check Interval

This function enables you to set the accuracy check intervals. Four options are available: three months, six months, one year, or never. The default accuracy check interval is six months.

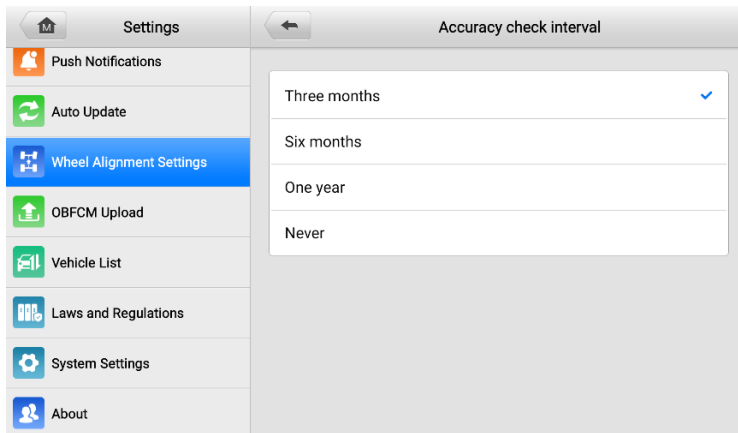

Figure 4-70 Accuracy Check Interval Setting Screen

4.8.6.4 Target Cleaning Interval

This function reminds the operator about the target cleaning frequency, which can be selected in terms of alignment numbers or intervals.

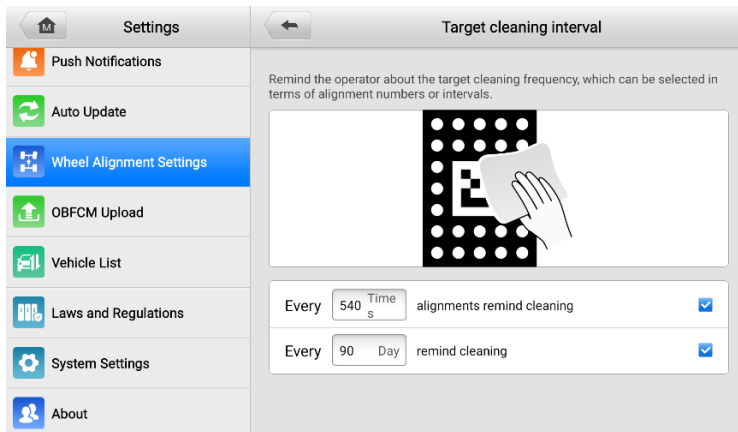

Figure 4-71 Target Cleaning Interval Setting Screen

4.8.7 Wheel Alignment Software Settings

Vehicle Inspection, Measurement Preparation, Measurement Results, Overhaul Report, Customized Specifications Management, and Restore Default Settings are included in

this section.

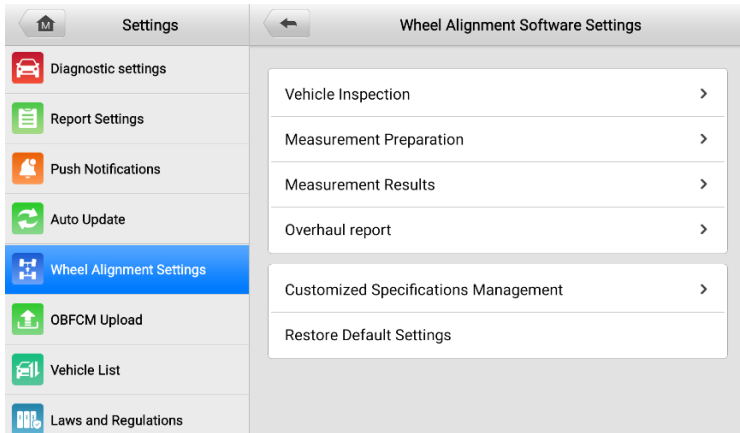

Figure 4-72 Wheel Alignment Software Settings Screen

4.8.7.1 Vehicle Inspection

This function enables you to:

1. Set whether to enable tire inspection or not. This setting will affect whether the tablet will guide you to perform Tread Depth & Pressure Inspection in the Vehicle Inspection procedure. For more details, refer to [Tread Depth & Pressure Inspection](#).
 - If the tire inspection is activated, you can set:
 - 1) Tread Depth Measuring Method: Single Check or All Tread Check.
 - 2) Minimum Tread Depth: When the tread depth is less than the minimum tread depth value you set, the tablet will prompt you to replace the tire immediately.
 - 3) Warning Tread Depth: When the tread depth is less than the value you set, the tablet will issue a warning.
2. Set whether to enable chassis inspection or not. This setting will affect whether the tablet will guide you to perform Chassis Inspection in the Vehicle Inspection procedure. For more details, refer to [Chassis Inspection](#).

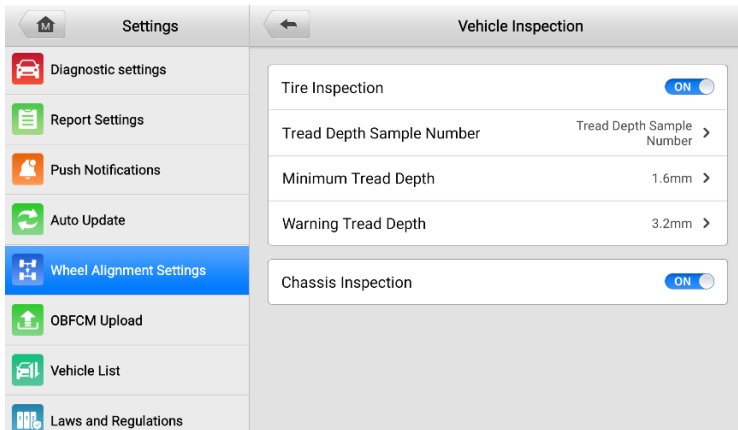

Figure 4-73 Vehicle Inspection Settings Screen

4.8.7.2 Measurement Preparation

This function enables or disables measurement preparation, and will affect whether the tablet guides you to measure the ride height. For more details, refer to [Ride Height Measurement](#).

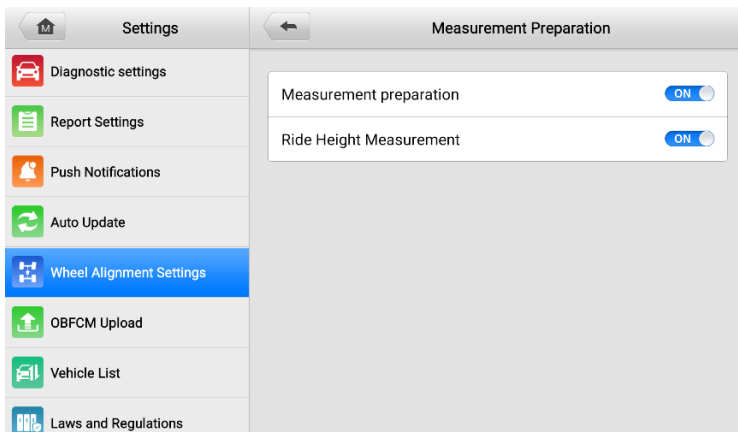

Figure 4-74 Measurement Preparation Setting Screen

4.8.7.3 Measurement Results

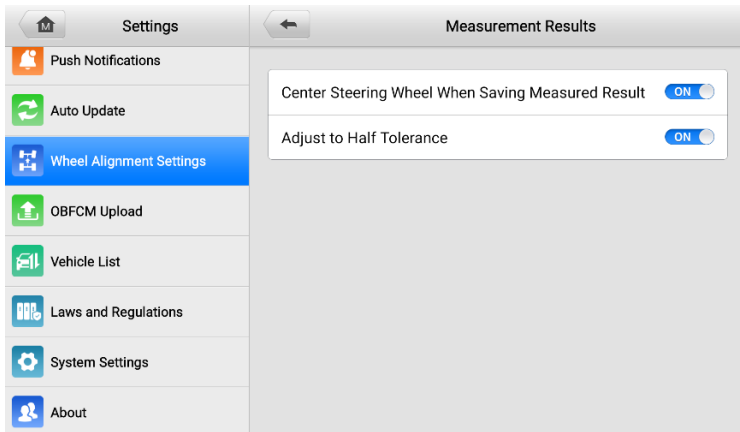

Figure 4-75 Measurement Results Setting Screen

This function enables you to:

1. Whether to center the steering wheel when saving the measured result.
 - Turn on the function
- 1) If the wheels are not in the straight-ahead position, tap **Save Before Repair** on the Measured Result screen to view the guide for setting the wheels straight ahead.

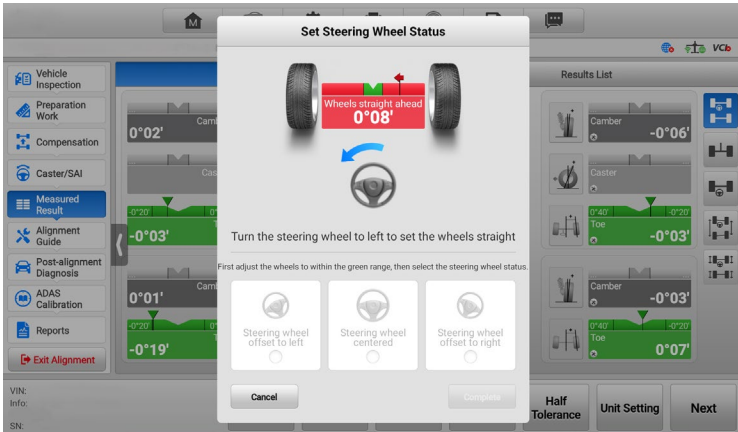

Figure 4-76 Save Before Repair Screen 1

- 2) When the wheels are in the straight-ahead position, the tablet will save the data automatically and display the following screen.

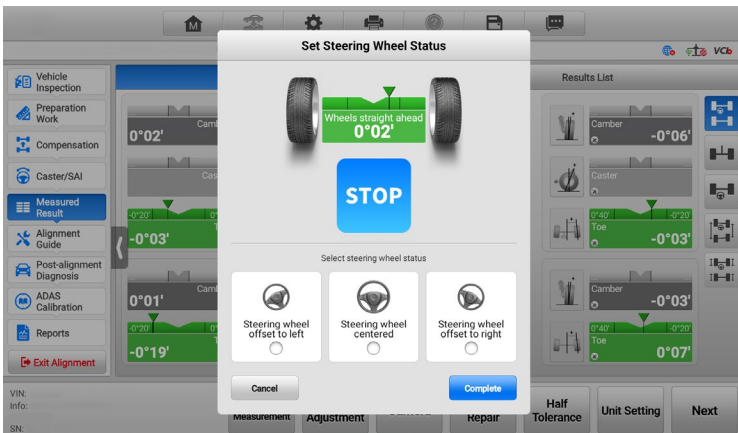

Figure 4-77 Save Before Repair Screen 2

- Turn off the function: the data will be saved directly after tapping **Save Before Repair** on the Measured Result screen.
2. Whether to switch to Half Tolerance mode.
 - 1) If the Half Tolerance mode is enabled, the Measured Result will be displayed in Half Tolerance mode, and the screen looks like the image below.



Figure 4-78 Measured Result (Half Tolerance) Screen

- 2) If Half Tolerance mode is disabled, the Measured Result will be displayed in Full Tolerance mode, and the screen looks like the image below.



Figure 4-79 Measured Result (Full Tolerance) Screen

4.8.7.4 Overhaul Report

This setting allows you to enable or disable the display of the chassis safety diagnostic report on the report screen after a wheel alignment operation. For more details, refer to [Reports](#).

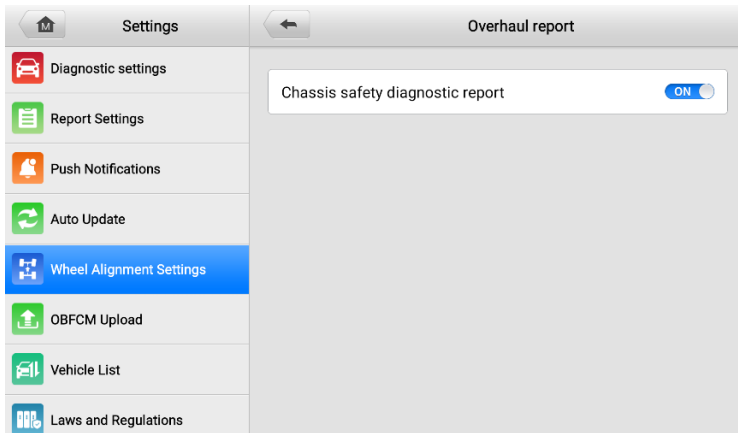

Figure 4-80 Overhaul Report Setting Screen

4.8.7.5 Customized Specifications Management

The function enables you to view or delete the customized specification data that has been stored for the vehicle. If you have not stored any customized specification data, the screen will display that no data is available when tapping the **Customized Specification Management** button.

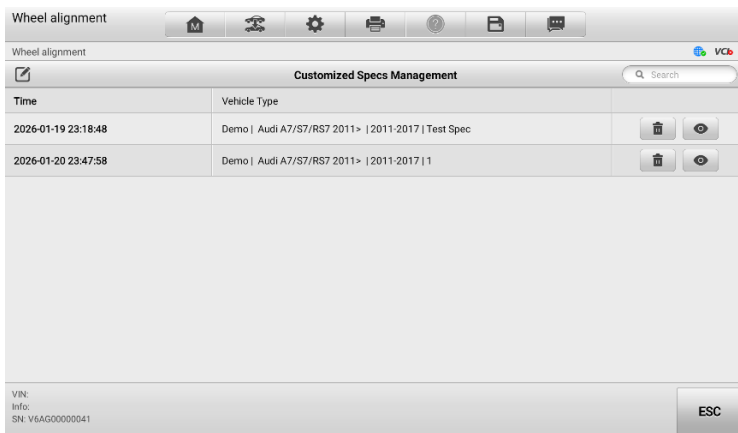

Figure 4-81 Customized Specs Management Screen

4.8.7.6 Restore Default Settings

This function restores the default settings of the wheel alignment software.

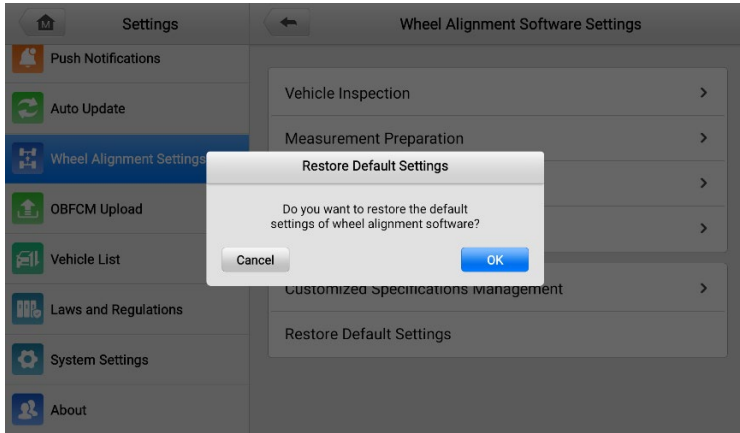

Figure 4-82 Restore Default Settings Screen

The default settings are as follows:

Table 4-2 Default Settings

Item	Default Setting
Angle Display Format	Degree & Minute
Toe Display Format	Degree & Minute
Ride Height Unit	mm
Tread Depth Unit	mm
Track Width & Wheelbase Unit	mm
Tire Pressure Unit	bar
Weight Unit	kg
Clamp Type	Rim Clamp

Item	Default Setting
Connect Tread Measuring Tool	Enable TBE Device Searching
Select Height Measuring Tool	Tape Measure
Mercedes Chassis Level Measuring Tool	Hand-held Inclinometer
Beep Setting	Turn On
Accuracy Check Interval	Six Months
Target Cleaning Interval	Times: 540 Times Days: 90 Days
Vehicle Inspection	Turn On
Tread Depth Sample Number	All Tread Check
Minimum Tread Depth	1.6 mm
Warning Tread Depth	3.2 mm
Chassis Inspection	Turn On
Measurement Preparation	Turn On
Center Steering Wheel When Saving Measured Result	Turn Off
Adjust to Half Tolerance	Turn On

4.9 Vehicle List

This option allows you to sort the vehicles either by alphabetical order or by frequency of

use.

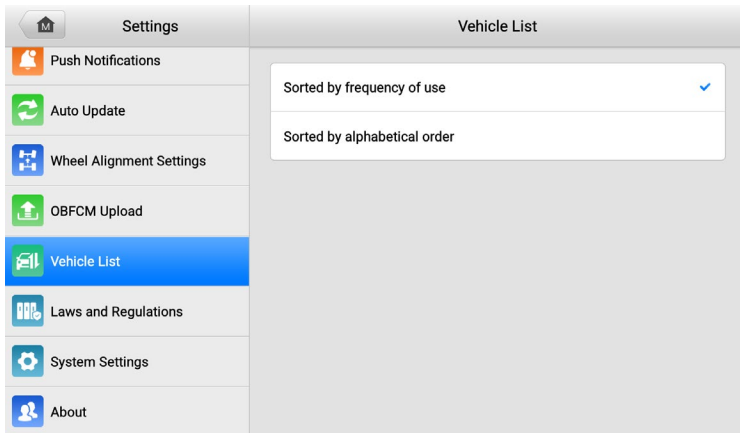

Figure 4-83 Vehicle List Screen

4.10 System Settings

This function provides you with direct access to the System Settings screen, where you can adjust various system settings for the tablet, including wireless and network settings, sound, display, and language settings.

4.11 About

The About function provides information about the MaxiSys diagnostics device, including the product name, version, hardware, and serial number.

5 Diagnostics

The Diagnostics application can retrieve ECU information, read & erase DTCs, and view live data. It can also access the electronic control modules of multiple vehicle control systems, including but not limited to the engine, transmission, antilock brake system (ABS), and airbag system (SRS).

5.1 Establishing Vehicle Communication

The Diagnostics operations require connecting the MaxiSys tablet to the test vehicle through the VCI device. To establish proper vehicle communication with the tablet, you need to perform the following steps:

1. Connect the VCI device to the vehicle's DLC for both communication and power source.
2. Connect the VCI device to the tablet via Bluetooth pairing or USB cable connection.
3. When the above steps are completed, check the VCI shortcut on the bottom bar of the screen. If a green BT or USB icon displays in the lower-right corner, the MaxiSys tablet is ready to start vehicle diagnosis.

5.1.1 Vehicle Connection

The method used to connect the VCI device to a vehicle's DLC depends on the vehicle's configuration as follows:

- A vehicle equipped with an On-Board Diagnostics Two (OBDII) management system supplies both communication and 12-volt power through a standardized J-1962 DLC.
- A vehicle not equipped with an OBDII management system supplies communication through a DLC connection, and in some cases supplies 12-volt power through the auxiliary power outlet adapter receptacle or a connection to the vehicle battery.

5.1.2 VCI Connection

After the VCI device is properly connected to the vehicle, the Power LED on the VCI device will turn on steadily, and a beeping sound will be heard, which indicates that it is ready to establish communication with the tablet.

Coming with the MaxiSys tool kit, the VCI device supports two communication methods with the tablet: Bluetooth or a USB cable.

Pairing Up via Bluetooth

In open areas, the working range for Bluetooth communication is about 50 m (164.04 feet), giving technicians greater mobility to perform vehicle diagnostics from anywhere in the repair shop.

To expedite multi-vehicle diagnostics, more than one VCI can be used in busy repair shops, enabling technicians to quickly pair their MaxiSys tablet with each VCI via Bluetooth and therefore eliminating the need to unplug the VCI from one vehicle and then connect it to another each time a new vehicle comes in for repairs.

➤ To pair the tablet with the VCI device via Bluetooth

1. Power up the tablet.
2. Select the **VCI Manager** application from the MaxiSys Job Menu.
3. When the **VCI Manager** application is launched, select **VCI BT** from the connection mode list, and swipe the Bluetooth toggle button to **ON**. The device will automatically scan for available VCI devices for Bluetooth pairing. The found devices are listed in the Settings section on the right side of the screen.

NOTE

If no VCI device is found, this may indicate that the signal strength is too weak to be detected. Reposition the VCI device and remove any objects that may cause signal interference. Tap the **Scan** button in the top-right corner to rescan for VCI.

4. Typically, the VCI device name displays as “Maxi-” followed by a serial number. Select the VCI device for pairing. (If more than one VCI is used in the shop, ensure the correct VCI is selected to pair.)
5. When the pairing is successful, the connection status displays as “Connected.”
6. The VCI icon on the tablet navigation bar at the bottom of the screen displays a green circle BT icon when the tablet and the VCI are connected.

Refer to [VCI Bluetooth Pairing](#) for additional information.

USB Cable Connection

The USB cable connection is a simple and quick way to establish communication between the tablet and the VCI device. After properly connecting the USB cable from the tablet to the VCI device, the VCI shortcut at the bottom of the screen displays a green USB cable badge, and the connection LED on the VCI device lights solid green, indicating connection between the devices is successful. The MaxiSys tablet is now ready to perform vehicle diagnostics.

 **NOTE**

When both the communication methods are applied at the same time, the MaxiSys system will use the USB communication as the default priority.

5.1.3 No Communication Message

- A. If the tablet is unable to connect to the VCI, an “Error” message displays. An “Error” message indicates the tablet is not communicating with the VCI device. Troubleshoot the error by performing the following steps:
- Ensure the VCI device is powered on.
 - When using the wireless connection, ensure the network is configured correctly, and the proper device has been connected.
 - If the tablet loses communication abruptly during diagnostics, ensure no objects are causing signal interruption.
 - Ensure the VCI device is properly positioned with the VCI front side up.
 - Move the tablet closer to the VCI device. If using a wired connection, ensure the cable is securely attached to the VCI.
 - Ensure the connection LED on the VCI device is lit for the selected communication type: Bluetooth or USB cable.
- B. If the VCI device is unable to establish a communication link, a message will display troubleshooting instructions. Possible causes for the communication error include:
- The VCI device is unable to establish a communication link with the vehicle.
 - A vehicle system has been selected for diagnosis that is not supported by the vehicle.
 - There is a loose connection.
 - There is a blown vehicle fuse.
 - The vehicle or the data cable has a wiring fault.
 - There is a circuit fault in the data cable or adapter.
 - The vehicle identification is incorrectly entered.

5.2 Getting Started

Before using the Diagnostics application for the first time, ensure the VCI device is properly connected to and is communicating with the tablet. See [Establish Vehicle Communication](#).

5.2.1 Vehicle Menu Layout

When the VCI device is properly connected to the vehicle and paired with the tablet, the platform is ready to start vehicle diagnosis. Tap the **Diagnostics** application button on the MaxiSys Job Menu, and the Vehicle Menu is displayed on the screen.



Figure 5-1 Vehicle Menu Screen











1. Top Toolbar Buttons
2. Manufacturer Buttons

5.2.1.1 Top Toolbar Buttons

The operations of the Toolbar buttons at the top of the screen are listed and described in the table below:

Table 5-1 Top Toolbar Buttons

Button	Name	Description
	Home	Returns to the MaxiSys Job Menu.

Button	Name	Description
	VID	Tap this button to open a drop-down list: <ul style="list-style-type: none"> ● Tap Auto Detect for auto VIN detection. ● Tap Manual Input to enter VIN code or license number manually. ● Tap Scan VIN/License to scan the VIN code/license number with the camera.
	All	Displays all the vehicle makes in the vehicle menu.
	Favorites	Displays user-selected favorite vehicle makes.
	History	Displays the stored test vehicle history records. This option provides direct access to the previously tested vehicle recorded during the previous test. See Vehicle History .
	America	Displays the American vehicle menu.
	Europe	Displays the European vehicle menu.
	Asia	Displays the Asian vehicle menu.
	China	Displays the Chinese vehicle menu.
	Search	Tap inside the search field to display a virtual keyboard and input the vehicle manufacturer to test.
	Cancel	Tap this button to exit the search screen or to cancel an operation.

5.2.1.2 Manufacturer Buttons

The Manufacturer buttons display the various vehicle brand names. Select the manufacturer button after the VCI device is properly connected to the test vehicle to manually select the vehicle information.

5.3 Vehicle Information Identification

The MaxiSys diagnostics system supports five methods of vehicle identification.

1. Auto Detect
2. Manual Input
3. Scan VIN/License
4. Manual Vehicle Selection
5. OBDII Direct Entry

5.3.1 Auto Detect

➤ **To identify vehicle information via auto detect**

1. Tap the blue **VID** button on the top left of the screen.

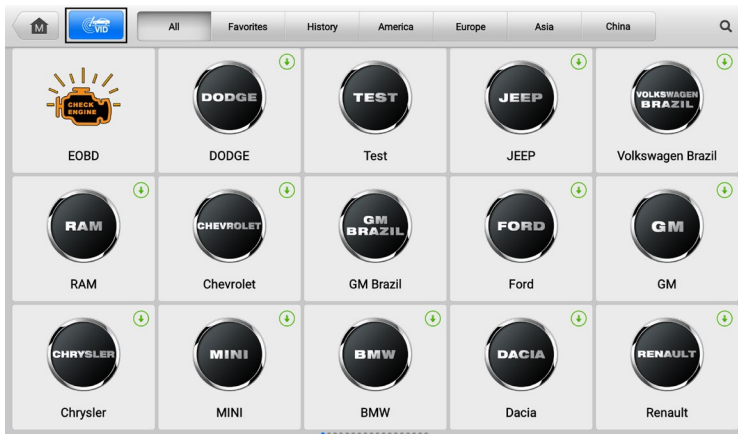

Figure 5-2 Auto Detect Screen 1

2. Select **Auto detect** from the drop-down menu. Then the vehicle will be identified automatically.



Figure 5-3 Auto Detect Screen 2



Figure 5-4 Auto Detect Screen 3

The VIN Auto Detect function is still available after selecting a vehicle manufacturer.

Select a vehicle manufacturer from the Vehicle Menu screen, select **Automatic Selection** from the Select Diagnostic Type screen, and tap **Read**. This enables the system to retrieve the VIN information automatically. Alternatively, you can input the VIN manually.

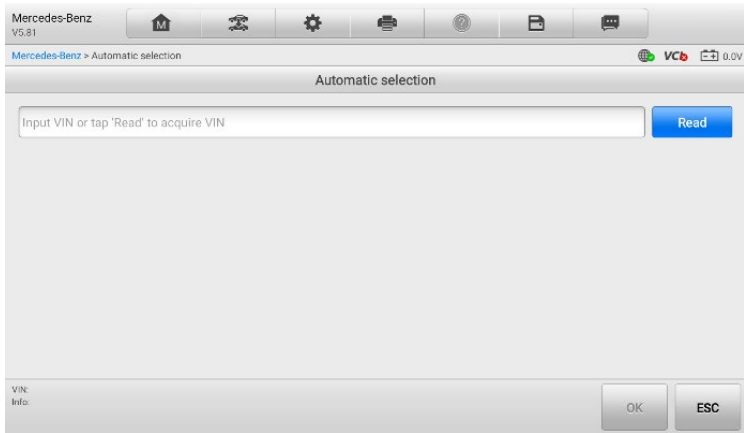

Figure 5-5 Automatic Selection Screen

5.3.2 Manual Input

- **To identify vehicle information via manual input**
 1. Select the blue **VID** button on the top left of the screen.
 2. Select **Manual input** from the drop-down menu.



Figure 5-6 Manual Input Screen 1

3. Tap the input box and enter the correct VIN or license number. Then tap **OK**, and the vehicle will be identified.



Figure 5-7 Manual Input Screen 2

5.3.3 Scan VIN/License

- **To identify vehicle information via VIN/license scanning**
 1. Select the blue **VID** button on the top left of the screen.
 2. Select **Scan VIN/License Plate** from the drop-down menu.



Figure 5-8 VIN Scanning Screen 1

3. Position the camera so that the VIN (located on the vehicle dash or vehicle door jamb) appears within the scanning frame. Then the VIN is scanned and

recognized automatically, and the result will appear in the Recognition Result dialog box.

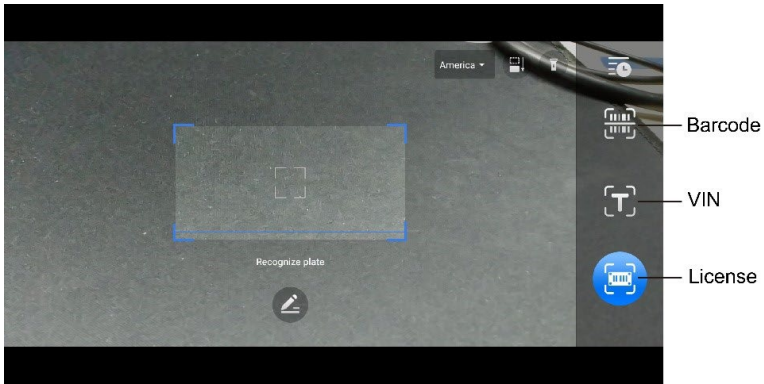

Figure 5-9 VIN Scanning Screen 2

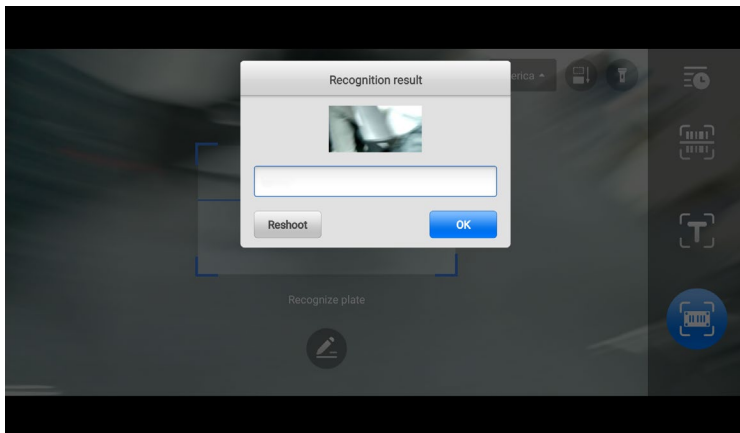

Figure 5-10 VIN Scanning Screen 3

4. Tap **OK** to confirm the VIN.

5.3.4 Manual Vehicle Selection

➤ **To identify vehicle information via manual selection**

1. Select the vehicle manufacturer icon.



Figure 5-11 Manual Selection Screen 1

2. Select **Manual Selection**. Then select the vehicle information, such as Brand, Model, Capacity, Engine Type, and Model Year. Then tap **OK** to confirm the VIN.

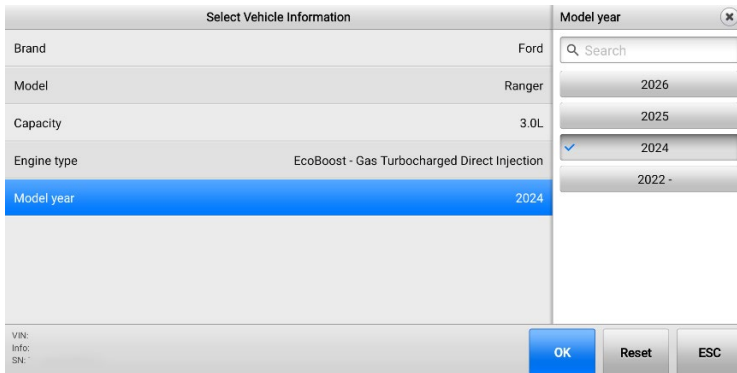

Figure 5-12 Manual Selection Screen 2

5.3.5 OBDII Direct Entry

The tablet may occasionally fail to identify the vehicle. For such vehicles, users can perform a generic OBDII or EOBBD diagnostics via the OBDII Direct Entry mode. For details, refer to [Generic OBDII Operations](#).

5.4 Navigation

5.4.1 Diagnostics Screen Layout

After the vehicle information is selected, tap **OK** in the bottom-right corner of the screen to open the Main Menu screen. This menu provides two functions: Auto Scan and Control Unit.

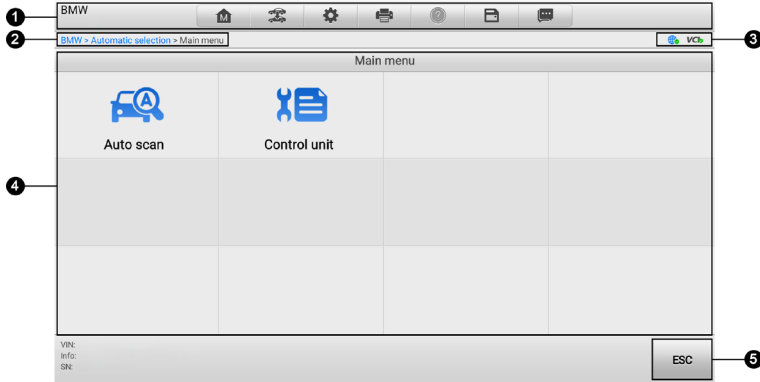



Figure 5-13 Main Menu Screen







1. Diagnostics Toolbar
2. Current Directory Path
3. Status Information Bar
4. Main Section
5. Function Buttons

5.4.1.1 Diagnostics Toolbar

The Diagnostics Toolbar contains buttons that allow you to print or save the displayed data and perform other operations. The table below provides a brief description of the operations of the Diagnostics Toolbar buttons:

Table 5-2 Diagnostics Toolbar Buttons

Name	Button	Description
Home		Tap to return to the MaxiSys Job Menu.

Name	Button	Description
Vehicle Swap		Exits the diagnostics session and returns to the Vehicle Menu screen to select another vehicle for testing.
Settings		Opens the Settings screen. See Settings .
Print		Saves and prints a copy of the displayed data. See Printing Settings .
Help		Provides instructions or tips for the operations of various diagnostic functions.
Save		Opens a submenu with options for data storage.
Data Logging		Use this function when encountering an error while testing or diagnosing a vehicle. This function will record the communication data and ECU information about the test vehicle and send it to Autel's technical staff to review and provide solutions. Go to the Support application to follow up on the processing progress. See Data Logging .

 **NOTE**

The Diagnostics Toolbar (located at the top of the screen) will be active throughout the diagnostic session for tasks such as printing and saving the displayed data, obtaining help information, or performing data logging.

➤ **To print data in Diagnostics**

1. Tap the **Diagnostics** application button on the MaxiSys Job Menu. The Print button on the Diagnostics Toolbar is available throughout all Diagnostics operations.
2. Tap **Print**, and a drop-down menu will display.
 - a) **Print this page** — prints a screenshot copy of the current screen.
 - b) **Print all data** — prints a PDF copy of all displayed data.
3. A temporary file will be created and sent to the printer via the computer.

4. When the file is sent, a confirmation message is displayed.

 **NOTE**

Make sure the tablet and the printer are connected either by Wi-Fi or LAN before printing. For more instructions on printing, see [Printing Settings](#).

➤ **To submit Data Logging reports in Diagnostics**

1. Tap the **Diagnostics** application button from the MaxiSys Job Menu. The Data Logging button on the Diagnostics Toolbar is available throughout all Diagnostics operations.
2. Tap **Data Logging** to display the error options. Select a specific error, then tap **OK**, and a submission form will display, allowing you to fill in the report information.
3. Tap **Send** in the upper-right corner of the screen to submit the report form via a network. A confirmation message displays when sent successfully.

5.4.1.2 *Current Directory Path*

The Current Directory Path shows all directory names that lead to the current page.

5.4.1.3 *Status Information Bar*

The Status Information Bar at the top-right of the Main Section displays the following items:

1. **Network Status Icon** — indicates whether a network is connected.
2. **VCI Icon** — indicates the communication status between the tablet and the VCI device.
3. **Battery Icon** — indicates the battery status of the vehicle.

5.4.1.4 *Main Section*

The Main Section varies depending on the stage of operations, which shows vehicle identification selections, the main menu, test data, messages, instructions, and other diagnostic information.

5.4.1.5 *Function Buttons*

The Function Buttons displayed at the bottom of the screen vary by operation. Functions include navigation, reporting, and code clearing. The functions of these buttons will be described in the following sections when relevant.

5.4.2 Screen Messages

Messages display when additional input is required before proceeding. There are mainly three types of on-screen messages: Confirmation, Warning, and Error.

5.4.2.1 Confirmation Messages

This type of message usually displays as an “Information” screen when you are about to perform an action that cannot be reversed, or when an action has been initiated, and confirmation is needed to continue.

When a user response is not required, the message displays briefly.

5.4.2.2 Warning Messages

This type of message displays when completing the selected action may result in an irreversible change or loss of data. An example of this type of message is the “Erase Codes” message.

5.4.2.3 Error Messages

Error messages display when a systemic or procedural error has occurred. Possible errors include cable disconnection and communication interruption.

5.5 Diagnostics Menu

The Diagnostics application enables you to establish a data connection to the vehicle’s ECU through the VCI device for vehicle diagnosis and maintenance.

The Main Menu screen (see [Figure 5-13 Main Menu Screen](#)) navigates users to read and clear codes and perform other comprehensive automotive diagnostics functions. After the function is selected, the tablet will establish communication with the vehicle through the VCI device and enter the corresponding function menu or selection menu.

5.6 Diagnostics Functions

There are two options available when accessing the diagnostics function:

1. Auto Scan — starts auto scanning for all the available systems on the vehicle.
2. Control Unit — displays a selection menu for all the available control units of the test vehicle.

Auto Scan

The Auto Scan function performs a comprehensive scanning of all the systems in the

vehicle ECU to locate faults and retrieve DTCs.

The main section of the Auto Scan screen displays a system list for most vehicles.

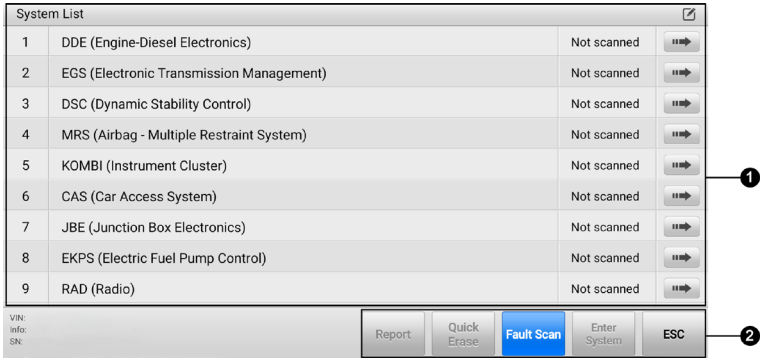

Figure 5-14 Auto Scan Screen

1. Main Section

- Column 1 — displays the system numbers.
- Column 2 — displays the scanned systems.
- Column 3 — displays the scan results.
 - ✧ **Fault | #:** Indicates there is/are detected fault code(s) present; “#” indicates the quantity of detected faults.
 - ✧ **Pass | No Fault:** Indicates the system was scanned and no fault has been detected.
 - ✧ **Not Scanned:** Indicates the system has not been scanned, or the vehicle control system has been detected, but the tablet cannot access it.
 - ✧ **No Response:** Indicates the system has not received a response.
- Column 4 — tap the button to enter a system for performing further diagnostics.

2. Function Buttons

The table below provides a brief description of the Function Buttons:

Table 5-3 Function Buttons in Auto Scan Screen

Name	Description
Report	Displays the diagnostic data in report form.

Name	Description
Quick Erase	Erases all fault information after scanning.
Fault Scan	Scans vehicle system modules.
Enter System	Enters the ECU system.
ESC	Returns to the previous screen or exits Auto Scan.

Control Unit

The Control Unit function allows you to manually locate a required control system for testing through a series of choices. Simply follow the menu-driven procedures, and make proper selections each time; the program will guide you to the diagnostics function menu.

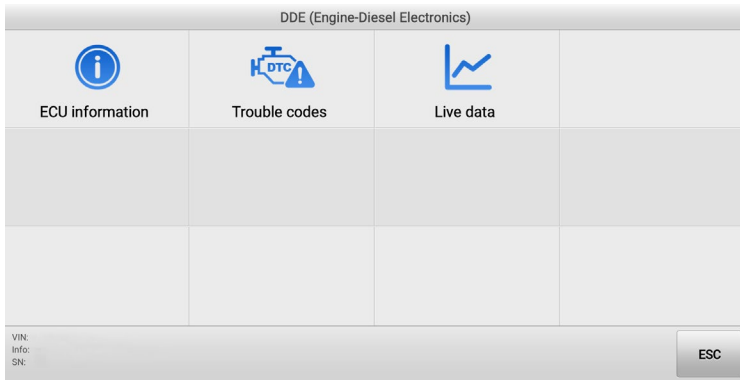

Figure 5-15 Diagnostics Function Screen

Available functions may vary by vehicle. The function menu may include:

- **ECU Information** — displays detailed ECU information. Select to display the information screen.
- **Trouble Codes** — contains Read Codes and Erase Codes. The former displays detailed DTC information retrieved from the vehicle control module. The latter allows you to erase DTCs and other data from the ECU.
- **Live Data** — retrieves and displays live data and parameters from the vehicle's ECU.

5.6.1 ECU Information

This function retrieves and displays the specific information about the tested control unit, including unit type, version numbers, and other information.

ECU information	
Programming date	17.12.2015
Kilometer reading when programming	153000
Part number	7799854
Production date (day, month, year)	28.11.2005
Supplier	Bosch
VIN: info: SN:	

ESC

Figure 5-16 ECU Information Screen

1. Main Section — the left column displays the item names; the right column displays the specifications or descriptions.
2. Function Button — in this case, only an **ESC** button is available; tap it to exit after viewing.

5.6.2 Trouble Codes

Tap **Trouble Codes** from the Diagnostics Function screen, and the tablet will automatically read the DTC information in the ECU.

Trouble codes		
DTC	Status	Description
003FC0	present	Digital Diesel Electronics (DDE), Mass Air Flow (MAF) sensor
VIN: SN:		

Freeze frame
Erase codes
Read codes
Search
ESC

Figure 5-17 Trouble Codes Screen

1. Main Section
 - Column 1 — displays the retrieved codes from the vehicle.
 - Column 2 — indicates the status of the retrieved codes.
 - Column 3 — displays detailed descriptions for the retrieved codes.

- **Snowflake Icon** — only displays when freeze frame data is available for viewing. Tap to display the Freeze Frame screen.

2. Function Buttons

- **Freeze Frame** — activated if there is freeze frame data for viewing. Tap to display the Freeze Frame screen.
- **Erase Codes** — tap to erase codes and other data from the ECU. It is recommended to read DTCs and make necessary repairs before erasing the codes.

After reading the retrieved codes from the vehicle and making certain repairs, you can erase the codes from the vehicle using this function. Before performing this function, make sure the vehicle's ignition key is in the ON (RUN) position with the engine off.

➤ **To erase codes**

1. Tap **Erase Codes** in the function buttons.
 2. A warning message displays to inform you of data loss when this function is applied.
 - ✧ Tap **Yes** to continue. A confirming screen displays when the operation is successfully done.
 - ✧ Tap **No** to exit.
 3. Tap **ESC** on the confirming screen to exit the Erase Codes screen.
 4. Check the Read Codes function again to ensure the operation is successful.
- **Read Codes** — retrieves and displays the DTCs from the vehicle control system. The Read Codes screen varies for each vehicle being tested.
 - **Search** — tap to search the selected DTC for additional information on the Internet.
 - **ESC** — tap it to return to the previous screen or exit the function.

5.6.3 Live Data

After entering the Live Data screen, parameter groups are displayed. Tap a group to view the detailed live data for the selected system.

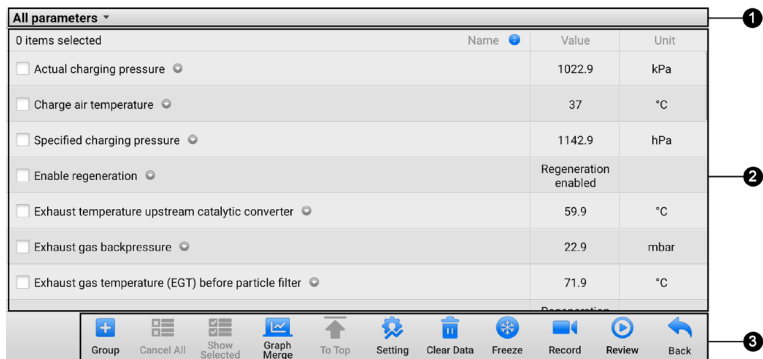

Figure 5-18 Live Data Screen

1. Top Toolbar: Data Group Selection — tap the drop-down button to select the data group needed.
2. Main Section
 - Name Column — displays the parameter names.
 - ◇ Check Box — tap to select or deselect the item.
 - ◇ Drop-down Button — tap to open a submenu that provides optional modes in which to display the data.
 - Value Column — displays the values of the parameter items.
 - Unit Column — displays the unit for the parameter values.

Tap the drop-down button on the right side of a parameter to open a submenu. Eight buttons are displayed: four Display Mode buttons and four control buttons.

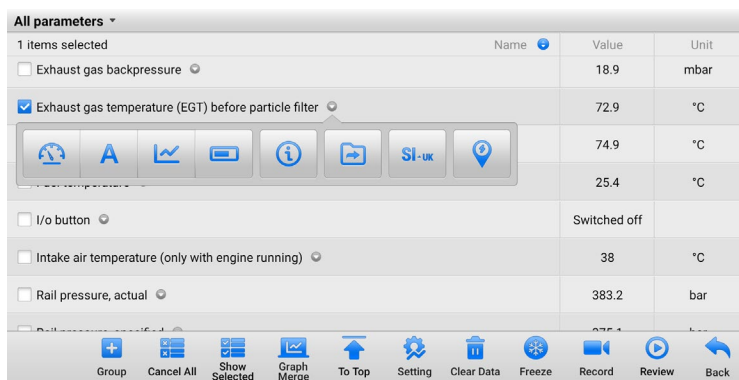





Figure 5-19 Display Mode and Control Buttons Screen

Display Mode

Four types of display modes are available for data viewing, allowing you to view various types of parameters in the mode best suited to represent the data.

Icon	Display Mode
	Analog Gauge Mode.
	Text Mode.
	Waveform Graph Mode. The digital-type parameters and status parameters are supported.
	Digital Gauge Mode. Only digital parameters are supported.

- a) **Analog Gauge Mode** — displays the parameters in gauge charts.



Figure 5-20 Analog Gauge Mode Screen

- b) **Text Mode** — the default mode that displays the parameters as a text list.
 c) **Waveform Graph Mode** — displays the parameters in waveform graphs.



Figure 5-21 Waveform Graph Mode Screen

In this mode, six control buttons are displayed on the right side of each parameter, allowing you to adjust the display status.

- 1) **Settings Button (SetY)** — sets the minimum and maximum value of the Y-axis.
- 2) **Scale Button for the X-axis** : four scales available for the X-axis: x1, x2, x4, and x8.
- 3) **Scale Button for the Y-axis** : three scales available for the Y-axis: x1, x2, and x4.
- 4) **Edit Button** — edit the waveform color and the line thickness.
- 5) **Zoom-in/Zoom-out Button** / — tap to view the selected data graph in full screen or to exit the full screen.
- 6) **Exit Button** — tap to exit the waveform graph mode.

NOTE

The **Settings Button (SetY)** is hidden in full-screen mode.

➤ **To edit the waveform color and line thickness**

1. Select a parameter to display in Waveform Graph mode.
2. Tap the **Edit** button, and an edit window is displayed.

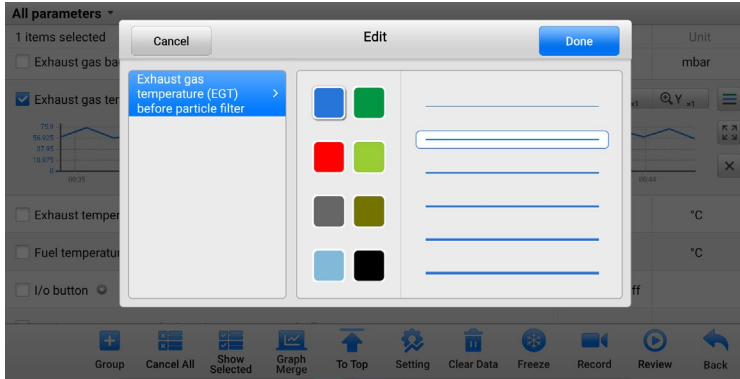

Figure 5-22 Waveform Editing Screen

3. The parameter item is selected automatically in the left column.
 4. Select a color from the second column.
 5. Select a line thickness from the right column.
 6. Tap **Done** to save the setting and exit, or tap **Cancel** to exit without saving.
- d) **Digital Gauge Mode** — displays the parameters in the form of a digital gauge graph.

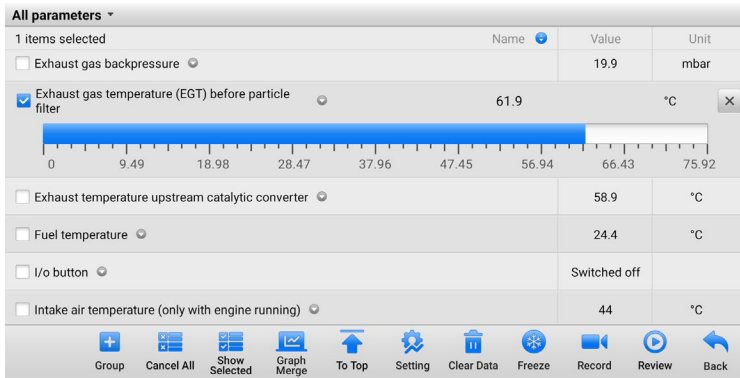





Figure 5-23 Digital Gauge Mode Screen

Control Button

Four control buttons are displayed: Information, Add to Group, Unit Switching, and Trigger Setting.

Icon	Description
	Information
	Add to Group
	Unit Switching
	Trigger Settings

- a) **Information** — active when additional information is available.
- b) **Add to Group** — tap to add the selected parameters to the custom group.
- c) **Unit Switching** — tap to switch the unit for the parameter value.
- d) **Trigger Settings**

Tap the drop-down button on the right side of a parameter to open a submenu, and tap the Trigger Settings button to display the “Trigger Settings” window.

On the Trigger Settings screen, you can set a standard range by filling in a minimum value and a maximum value. When this range is exceeded, the trigger function will be executed, and the device will automatically record and save the generated data. You can check the saved live data by tapping **Review** at the bottom of the screen.



Figure 5-24 Trigger Settings Screen

Two buttons and two input boxes are available in the Trigger Settings window.

- 1) **Trigger** — switches the trigger on and off. The trigger is ON by default.
- 2) **Buzzer alarm** — switches the alarm on and off. The alarm function makes a beep sound as an alert when the data reading reaches the preset minimum or maximum

point. The buzzer alarm will only sound at the first trigger.

- 3) **MIN** — tap this input box to display a virtual keyboard to enter the required lower limit value.
- 4) **MAX** — tap this input box to display a virtual keyboard to enter the required upper limit value.

When the trigger is successfully set, a trigger mark displays in front of the parameter name. The mark is gray when it is not triggered and displays orange when triggered. Moreover, two horizontal lines display on each of the data graphs (when Waveform Graph Mode is applied) to indicate the alarm point. The limit lines are shown in different colors to differentiate them from the parameter waveforms.

3. Function Buttons

The operations of the available Function Buttons on the Live Data screen are described below:

- **Group** — select live data items and tap this button to add them to a new customer group or an existing one.
- **Cancel All** — tap to cancel all selected parameter items. Up to 50 parameters can be selected at a time.
- **Show Selected/Show All** — tap to switch between viewing selected parameters and all available items.
- **Graph Merge** — select 2–5 live data items and tap the button to merge their data graphs (for Waveform Graph Mode only) to compare different parameters.

To exit Graph Merge mode, tap the **Cancel merging** button at the bottom of the screen.

- **To Top** — tap to move a selected data item to the top of the list.
- **Setting** — tap to set the recording duration.
- **Clear Data** — tap to clear all cached live data.
- **Freeze** — displays the retrieved data in freeze mode.
 - ✧ Previous Frame — moves to the previous frame of frozen data.
 - ✧ Next Frame — moves to the next frame of frozen data.
 - ✧ Play/Pause — tap to play/pause the frozen data.
 - ✧ Resume — tap to exit the freeze data mode and return to normal data display.
- **Record** — tap to start recording the live data of the selected data items. The recorded live data can be viewed in the **Review** section at the bottom of the Live Data screen or in the Data Manager application.
 - ✧ Complete — tap to stop data recording and to return to normal data display.

- ✧ Flag — displays when the Record function is applied. Tap to set flags to note points of interest when recording data. Notes can be added during playback in the Review or Data Manager. Select the preset flag to open a pop-up window and input notes.

- **Review** — tap to review the recorded data.

NOTE

Only the data recorded during the current operation can be reviewed on the Live Data screen. All historical data can be reviewed from Review Data in the Data Manager application.

- ✧ Previous Frame — switches to the previous frame of recorded data.
- ✧ Next Frame — switches to the next frame of recorded data.
- ✧ Play/Pause — tap to play/pause the recorded data.
- ✧ Show Selected/Show All — tap to switch between viewing selected parameters and all available items
- ✧ Graph Merge — merges selected data graphs.
- ✧ Back — exits the review and returns to the Live Data screen.

- **Back** — returns to the previous screen or exits the function.

5.7 Generic OBDII Operations

The OBDII/EOBD vehicle diagnosis option provides a quick way to check DTCs, isolate the cause of an illuminated malfunction indicator lamp (MIL), check monitor status before emissions certification testing, and perform other emissions-related services. The OBDII direct access option is also used for testing OBDII/EOBD compliant vehicles that are not included in the database.

5.7.1 General Procedure

➤ To access the OBDII/EOBD diagnostics functions

1. Tap the **Diagnostics** button from the MaxiSys Job Menu. The Vehicle Menu displays.
2. Tap the **EOBD** button. There are two options to establish communication with the vehicle.
 - Auto Scan — select it to establish communication using each protocol to determine which one the vehicle is using.
 - Protocol — select it to open a submenu of various protocols. A communication protocol is a standardized method of data communication between an ECM and a diagnostic tool. Global OBD may use several

different communication protocols.

3. Select a specific protocol if the **Protocol** option is selected. Wait for the OBDII/EOBD Diagnostic Menu to appear.

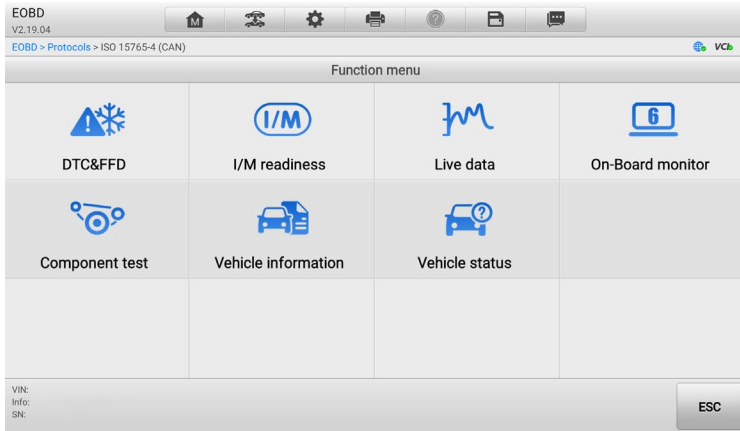

Figure 5-25 EOBD Diagnostic Menu

4. Select a function option to continue.
 - DTC & FFD
 - I/M Readiness
 - Live Data
 - On-Board Monitor
 - Component Test
 - Vehicle Information
 - Vehicle Status

NOTE

The supported functions may vary by vehicle.

5.7.2 Function Descriptions

This section describes the various functions of each diagnostic option.

5.7.2.1 DTC & FFD

When this function is selected, the screen displays a list of Stored Codes and Pending Codes. When the Freeze Frame data of certain DTCs are available for viewing, a snowflake button will display on the right side of the DTC item. The Erase Codes and

Read codes functions can be applied by tapping the Function Buttons at the bottom of the screen.

- **Current Codes**

Current codes are emission-related DTCs from the ECM of the vehicle. OBD II/EOBD Codes have a priority according to their emission severity, with higher-priority codes overwriting lower-priority ones. The priority of the code determines the illumination of the Malfunction Indicator Lamp (MIL) and the code erase procedure. Manufacturers rank codes differently, so DTCs may vary by vehicle.

- **Pending Codes**

These are codes whose storing conditions have been met during the last drive cycle, but that need to be met on two or more consecutive drive cycles before the DTC is stored. The purpose of displaying pending codes is to assist the service technician after a vehicle repair when diagnostic information is cleared, by reporting test results after a single driving cycle.

- a) If a test fails during the driving cycle, the DTC associated is reported. If the pending fault does not occur again within 40 to 80 warm-up cycles, the fault is automatically cleared from memory.
- b) Test results reported do not necessarily indicate a faulty component or system. If test results indicate another failure after additional driving, a DTC is stored to indicate a faulty component or system.

- **Freeze Frame**

In most cases, the stored frame is the last DTC reported. Certain DTCs, those that have a greater impact on vehicle emissions, have a higher priority. In these cases, the DTC of the highest priority is the one for which the freeze frame records are retained. Freeze frame data includes a “snapshot” of critical parameter values at the time the DTC is stored.

- **Erase Codes**

This option is used to clear all emission-related diagnostic data, including DTCs, freeze frame data, and specific manufacturer-enhanced data from the vehicle ECM. This option resets the I/M Readiness Monitor Status for all vehicle monitors to Not Ready or Not Complete status.

A confirmation screen displays when the clear codes option is selected to prevent accidental loss of data. Select **Yes** on the confirmation screen to continue, or select **No** to exit.

5.7.2.2 *I/M Readiness*

This function is used to check the readiness of the monitoring system. It is a function to use before having a vehicle inspected for state emissions compliance. Selecting I/M Readiness opens a submenu with two choices:

- Since DTCs Cleared — displays the status of monitors since the last time the DTCs were erased.
- This Driving Cycle — displays the status of monitors since the beginning of the current drive cycle.

5.7.2.3 *Live Data*

This function enables the display of real-time PID data from the ECU. Displayed data includes analog and digital input and output, and system status information broadcast in the vehicle data stream.

Live data can be displayed in various modes; see [Live Data](#) for detailed information.

5.7.2.4 *On-Board Monitor*

This function allows you to view the results of On-Board Monitor tests. The tests are useful after the service when a vehicle's control module memory is already erased.

5.7.2.5 *Component Test*

This function enables dual-directional control of the ECM so that the diagnostic tool can transmit control commands to operate the vehicle systems. This function is useful for determining how well the ECM responds to a command.

5.7.2.6 *Vehicle Information*

This function enables the display of the vehicle identification number (VIN), calibration identification number, calibration verification number (CVN), and other information about the test vehicle.

5.7.2.7 *Vehicle Status*

This function checks the current condition of the vehicle, such as the communication protocols of OBDII modules, the number of fault codes, and the status of the Malfunction Indicator Light (MIL).

5.8 Diagnostics Report

5.8.1 Pre-Scan and Post-Scan Functions

After performing pre-scan and post-scan functions by entering the same maintenance order number, tap **Data Manager > Vehicle History** to select the historical test record named with the maintenance order number. Both the pre-scan results and post-scan results will be displayed in the same historical test record, which can be generated as a PDF report for easily comparing the changes between pre-scan and post-scan.

- **Pre-Scan Function**

Select and tap a vehicle button from the Vehicle Menu screen. Enter the maintenance order number in the pop-up box to scan and detect the whole vehicle. You can also add pictures to record the current condition of the vehicle. Once the pre-scan is completed, you are not allowed to perform the pre-scan again, and the scan results cannot be modified.

- **Post-Scan Function**

After the pre-scan is complete, exit the current test vehicle and tap the vehicle button from the Vehicle Menu screen to reconnect. Enter the same maintenance order number in the pop-up box. The screen for post-scan will display. The post-scan record will be generated when the scan is completed. The pre-scan results and post-scan results will be displayed in the same historical test record.

 **NOTE**

The post-scan function can be performed repeatedly. After exiting the vehicle, you only need to tap the vehicle button from the Vehicle Menu screen to reconnect, then enter the same maintenance order number in the pop-up box, and follow the steps to rescan. The last one is the final post-scan result.

5.8.2 Diagnostics Report Saving, Viewing, and Sharing

The diagnostics report can be reviewed, saved, and shared with others in many ways.

5.8.2.1 Diagnostics Report Saving

- Via the **History** function
 - 1) Tap the **Diagnostics** application button on the MaxiSys Job Menu, and select **History** on the top toolbar.

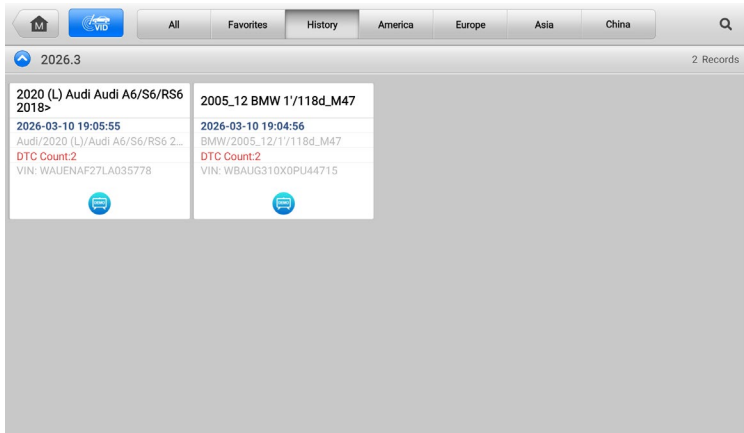

Figure 5-26 History Screen

- 2) Select a history record, and tap the **...** button in the upper-right corner.

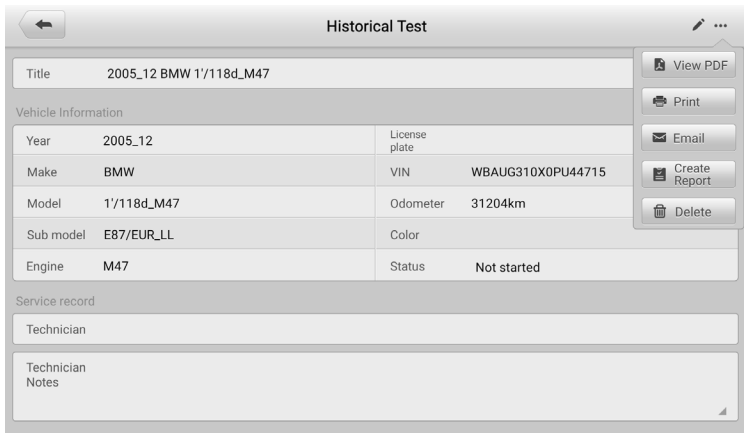

Figure 5-27 Historical Test Screen

- 3) Tap **Create Report**. Enter the license plate and current mileage. Tap **Save**.
- Via the **Auto Scan** function
 - 1) Enter the Auto Scan page and tap **Fault Scan** from the function buttons at the bottom of the screen.



Figure 5-28 Auto Scan Screen 1

- When the system scan is completed, tap **Report** from the function buttons at the bottom of the screen.

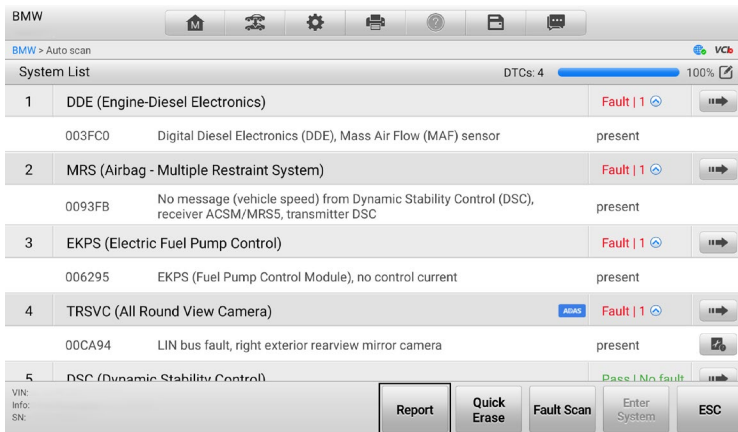



Figure 5-29 Auto Scan Screen 2

- Via the functions on the Diagnostics Toolbar

Diagnostics reports can also be saved while operating diagnostics functions, including Auto scan and Trouble codes.

- Tap the button on the Diagnostics Toolbar and select **Save as PDF**. Enter the odometer reading and tap **Save**. Tap the button on the upper-right of the screen and select a saved report to view it.

- ✧ Tap the  button on the Diagnostics Toolbar and select **Report to Cloud**. Enter the odometer reading. Tap **Save > View Report** to view the saved report.

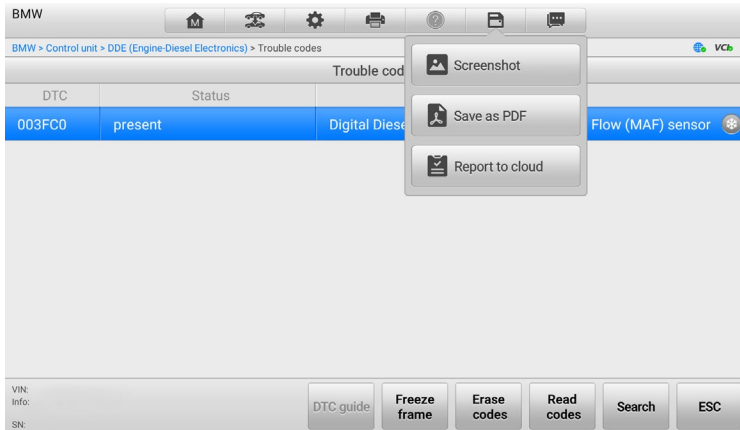



Figure 5-30 Trouble Codes Screen

5.8.2.2 Diagnostics Report Viewing

All the saved reports can be viewed in the Data Manager application.

- ✧ Tap **Data Manager > Vehicle History**. Select a specific vehicle history record and then tap  > **View PDF** in the upper-right corner to view the report.
- ✧ Once you have saved the reports by tapping the **Save as Report** button, tap **Data Manager > PDF** to view these reports.
- ✧ Once you have saved the reports by tapping the **Create Report** or **Report to Cloud** button, tap **Data Manager > Cloud Report** to view these reports.

5.8.2.3 Diagnostics Report Cloud Sharing

- 1) Tap **Data Manager > Cloud Report** to enter the Report List screen. Tap the **Diagnostics** button on the toolbar to display the diagnostics report.

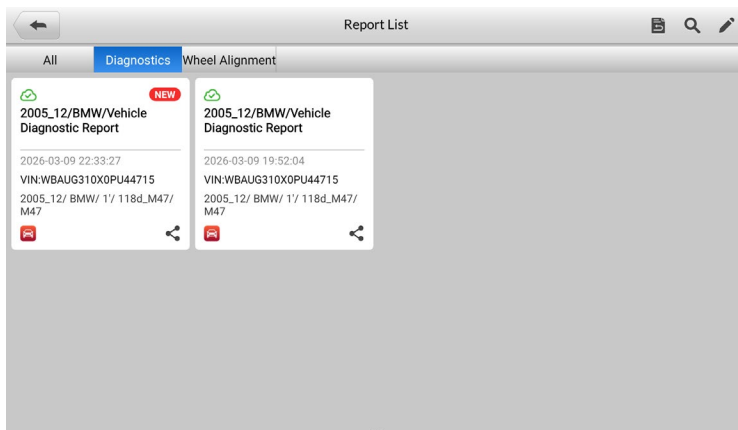



Figure 5-31 Report List Screen

2) Tap the  in the lower-right corner of the report.

 **NOTE**

A report marked with  indicates that it has been successfully uploaded to the cloud and can be shared with others, while a report marked with  indicates a failed cloud upload and cannot be shared.

3) There are three ways for report cloud sharing: scan the QR code, send by email, and send by SMS (via phone number).

5.9 Exit Diagnostics

The Diagnostics application operates while communication with the vehicle is still active. It is important to properly exit from the diagnostics operation screen to stop all communications with the vehicle before closing the Diagnostics application.

 **NOTE**

Damage to the vehicle electronic control module (ECM) may occur if communication is disrupted. Ensure all forms of communication links, such as data cable, USB cable, and wireless or wired network, are properly connected throughout the test. Exit all screens before disconnecting the test cable and power supply.

➤ **To exit the Diagnostics application**

- On an active diagnostics screen:
 1. Tap the **Back** or **ESC** button to exit a diagnostics session.
 2. Or tap the **Vehicle Swap** button on the Diagnostics Toolbar to return to the

Vehicle Menu screen.

- On the Vehicle Menu screen:
 1. Tap the **Back** button on the Navigation Bar at the bottom of the screen.
 2. Or tap the **Home** button on the Diagnostics Toolbar to exit the application directly and return to the MaxiSys Job Menu.
-

 **NOTE**

After exiting the Diagnostics application, the tablet will no longer communicate with the vehicle, and it is safe to open other MaxiSys applications.

6 Wheel Alignment Function

A vehicle's four wheels, steering mechanism, and front and rear axles are designed to maintain a specific relative position — a factory-set standard specification. This relative position may shift following component reinstallation or prolonged operation. The process of adjusting these parts back to their standard positions is defined as wheel alignment.

Proper wheel alignment ensures straight-line driving stability, enhances steering responsiveness, and reduces excessive tire wear and unnecessary power consumption. For these reasons, wheel alignment is a necessary procedure before vehicle operation.

In this chapter, technical specifications, precautions for use, wheel alignment preparations, and wheel alignment procedures are addressed.

6.1 Wheel Alignment Frame Specifications

The specifications of the wheel alignment frame are listed in the following table.

Table 6-1 Wheel Alignment Frame Specifications

Item	Description
Recommended Working Distance	2667 mm (105 in)
Supported Axle Distance	2032–5588 mm (80–220 in)
Supported Wheel Distance	1270–2490 mm (50–98.03 in)
Supported Rim Diameter (With Rim Clamp)	279–609 mm (11–24 in)
Supported Tire Diameter (With Tire Clamp)	482.6–939.8 mm (19–37 in)
Measurement Frequency (typ.)	9 times/s
Crossbar Lift Speed	50 mm/s

Item	Description
Operating Temp.	-10–50 °C (14 °F–122 °F)
Storage Temp.	-20–60 °C (-4 °F–140 °F)

6.2 Precautions for Wheel Alignment Operations

1. When the vehicle is on the lift, make sure the front wheels are centered with the steering wheel in the straight-ahead position.
2. After the vehicle is driven on the lift, wheel chocks should be placed on the front and rear of the two rear wheels to prevent the vehicle from rolling away.
3. Be careful when lifting the vehicle. Follow the safe operating procedures to lift vehicles.
4. When the vehicle is lifted to the required height, it can only be started after the insurance is in effect and safety is ensured.
5. Operating the lift is strictly prohibited when personnel are working underneath or around the vehicle.
6. Make sure the camera lens and target are clean.
7. When wheel clamps are required, ensure the pawls on each wheel clamp are in the same gear.
8. Strictly follow the software procedures and on-screen prompts.

6.3 Before Wheel Alignment

6.3.1 Preparatory Work

Before performing wheel alignment, please check and prepare:

1. The tablet is connected to an IWA500 Wi-Fi and Internet accessible network. Refer to [Wheel Alignment Frame Connection](#) and [Network Configuration](#) for details.
2. The ignition is turned off, and the IWA500 is connected to the charger to avoid battery drain, since the complete wheel alignment procedure may take a long time.
3. Prepare the following tools:

- 1) Wheel clamps (rim clamps), wheel clamps (tire clamps), and targets

NOTE

Here we select wheel clamps (rim clamps) for illustration.

- 2) Turnplate
- 3) Steering wheel holder stand tool and brake pedal depressor
- 4) Wheel chock
- 5) Steering wheel level

6.3.2 Function Selection

Two applications, Wheel Alignment and Advanced Wheel Alignment, are available on the Job Menu.

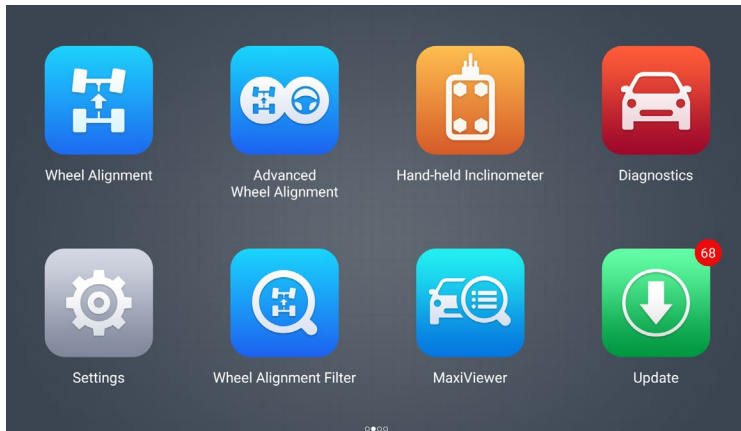

Figure 6-1 IWA500 Job Menu Screen

- 1) Select the **Wheel Alignment** application to perform the wheel alignment function.
- 2) Select the **Advanced Wheel Alignment** application to perform the wheel alignment and steering angle reset functions. Establish proper communication between the vehicle and tablet by connecting the VCI device to the vehicle's DLC. Refer to [Establish Vehicle Communication](#) for details.

NOTE

VCI connection is not required for the Wheel Alignment function, while it is mandatory for the Advanced Wheel Alignment function.

Table 6-2 Function Comparison

Function Procedures	Wheel Alignment	Advanced Wheel Alignment
Vehicle Inspection	✓	✓
Preparation Work	✓	✓
Compensation	✓	✓
Caster/SAI	✓	✓
Measured Result	✓	✓
Alignment Guide	✓	✓
SAS and Other Diagnosis Function		✓
ADAS Calibration		

Function Procedures	Wheel Alignment	Advanced Wheel Alignment
Reports	✓	✓

6.3.3 Vehicle Menu Layout

After selecting Wheel Alignment or Advanced Wheel Alignment from the MaxiSys Job Menu, the Vehicle Menu is displayed on the screen.







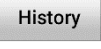





Figure 6-2 Vehicle Menu Screen

1. Top Toolbar Buttons
2. Manufacturer Buttons

6.3.3.1 Top Toolbar Buttons

The operations of the Toolbar buttons at the top of the screen are listed and described in the table below:

Table 6-3 Top Toolbar Buttons

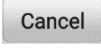
Button	Name	Description
	Home	Returns to the MaxiSys Job Menu.
	VID	Tap this button to open a drop-down list: <ul style="list-style-type: none"> ● Tap Auto Detect for auto VIN detection. ● Tap Manual Input to enter VIN code or license number manually. ● Tap Scan VIN/License to scan the VIN code/license number by camera.
	All	Displays all the vehicle makes in the vehicle menu.
	Favorites	Displays user-selected favorite vehicle makes.
	History	Displays the stored test vehicle history records. This option provides direct access to the previously tested vehicle recorded during the previous test. See Vehicle History .
	America	Displays the American vehicle menu.
	Europe	Displays the European vehicle menu.
	Asia	Displays the Asian vehicle menu.
	China	Displays the Chinese vehicle menu.
	Search	Tap inside the search field to display a virtual keyboard and input the vehicle manufacturer to test.
	Cancel	Tap this button to exit the search screen or to cancel an operation.

6.3.3.2 Manufacturer Buttons

The Manufacturer buttons display the various vehicle brand names. Select the

manufacturer button after the VCI device is properly connected to the test vehicle to manually select the vehicle information.

6.3.4 Vehicle Information Identification

After selecting an application to perform the desired functions, select an appropriate method to identify vehicle information. The supported identification methods for the two applications are detailed as follows:

Table 6-4 Methods to Identify Vehicle Information

Application Method	Wheel Alignment	Advanced Wheel Alignment
Auto Detect		✓
Manual Input	✓	✓
Scan VIN/License	✓	✓
Manual Selection	✓	✓

The procedures for vehicle information identification using Auto Detect, Manual Input, Scan VIN/License, and Manual Vehicle Selection in the Wheel Alignment function are identical to those in the Diagnostic function. For details, refer to [Vehicle Information Identification](#).

6.3.5 Parameters Customization

After vehicle information is selected, the **Specs** button becomes available in the function button section at the bottom of the screen. This button allows you to check and customize the wheel alignment parameters. It applies to vehicles whose parameters deviate from the original factory settings after chassis modification.

➤ **To customize wheel alignment parameters (take Audi vehicles as an example):**

1. Tap the **Specs** button to check the wheel alignment parameters. Then tap the **Customize Specs** button if any parameters require editing.

Front specifications		Rear specifications			
Front	Spec.	Measurement (Min.)	Measurement (Max.)	Adjustment (Min.)	Adjustment (Max.)
Total toe	0.00°	-0.50°	0.50°	-0.23°	0.23°
Left toe	0.17°	-0.33°	0.67°	--	--
Right toe	0.17°	-0.33°	0.67°	--	--
Left camber		--	--	--	--
Right camber		--	--	--	--
Cross camber	0.00°	-0.50°	0.50°	--	--
Left caster		--	--	--	--
Right caster		--	--	--	--

Instructions: Check the specification values
path:

VIN:
Info:
SN:

Customize Specs **Unit Setting** **ESC** **Start**

Figure 6-3 Alignment Specifications Screen

2. Tap to delete the parameters that need editing and input the correct values.

Front specifications		Rear specifications			
Front	Spec.	Measurement (-Tol.)	Measurement (+Tol.)	Adjustment (-Tol.)	Adjustment (+Tol.)
Total toe	<input type="text" value="0.00°"/>	<input type="text" value="0.50°"/>	<input type="text" value="0.50°"/>	<input type="text" value="0.23°"/>	<input type="text" value="0.23°"/>
Total toe (raised)	<input type="text" value="--"/>	<input type="text" value="--"/>	<input type="text" value="--"/>	<input type="text" value="--"/>	<input type="text" value="--"/>
Left toe	<input type="text" value="0.17°"/>	<input type="text" value="0.50°"/>	<input type="text" value="0.50°"/>	<input type="text" value="--"/>	<input type="text" value="--"/>
Right toe	<input type="text" value="0.17°"/>	<input type="text" value="0.50°"/>	<input type="text" value="0.50°"/>	<input type="text" value="--"/>	<input type="text" value="--"/>
Cross toe	<input type="text" value="--"/>	<input type="text" value="--"/>	<input type="text" value="--"/>	<input type="text" value="--"/>	<input type="text" value="--"/>
Left camber	<input type="text" value="--"/>	<input type="text" value="--"/>	<input type="text" value="--"/>	<input type="text" value="--"/>	<input type="text" value="--"/>
Right camber	<input type="text" value="--"/>	<input type="text" value="--"/>	<input type="text" value="--"/>	<input type="text" value="--"/>	<input type="text" value="--"/>
Cross camber	<input type="text" value="0.00°"/>	<input type="text" value="0.50°"/>	<input type="text" value="0.50°"/>	<input type="text" value="--"/>	<input type="text" value="--"/>

path:

VIN:
Info:
SN:

Save **Unit Setting** **ESC** **Start**

Figure 6-4 Edit Alignment Specifications Screen

3. Tap **Save** to enter the Save Specifications screen. Input the vehicle model and annotation for easy identification and retrieval. Then tap **OK** to save the parameters.

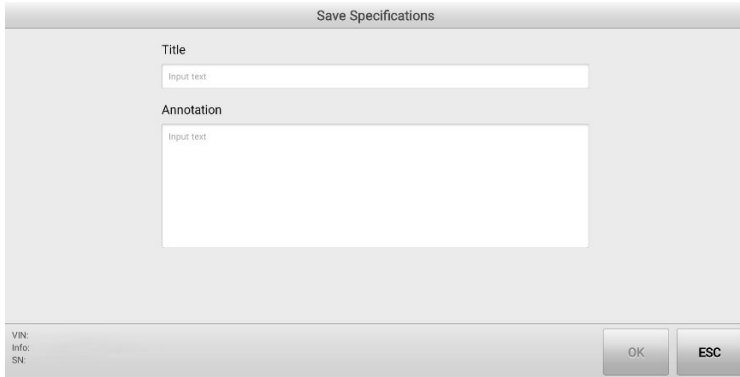

Figure 6-5 Save Specifications Screen 1

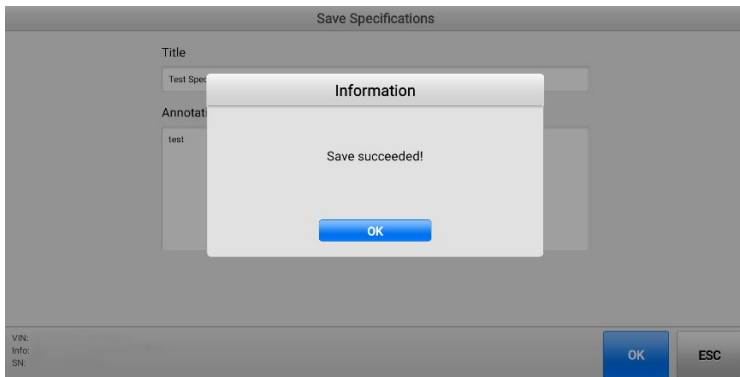

Figure 6-6 Save Specifications Screen 2

4. After the parameters are edited and saved, the tablet will return to the Wheel Alignment Parameters screen. Tap the **ESC** button, and the saved parameters will be automatically selected on the configuration information screen.

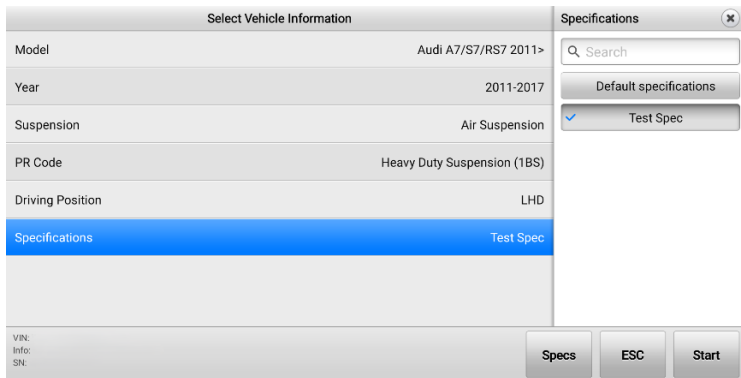

Figure 6-7 Select Configuration Screen

5. Tap **Start** and follow the screen step by step to continue to enter an information screen and finally enter the Vehicle Inspection screen.

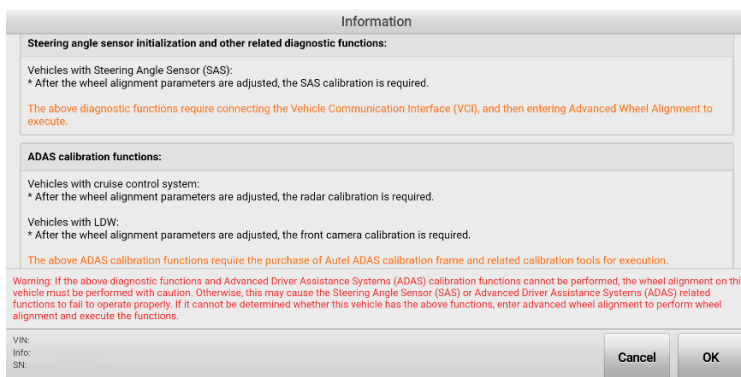

Figure 6-8 Wheel Alignment Information Screen

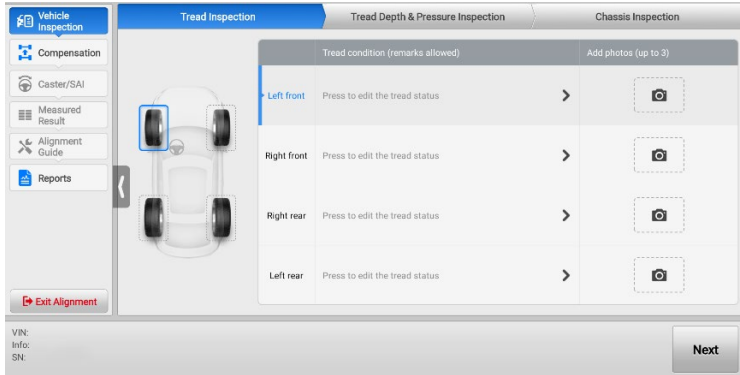

Figure 6-9 Wheel Alignment Procedure Screen

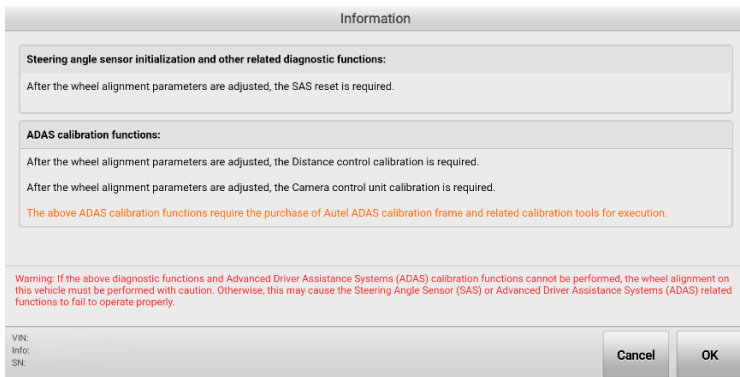

Figure 6-10 Advanced Wheel Alignment Information Screen

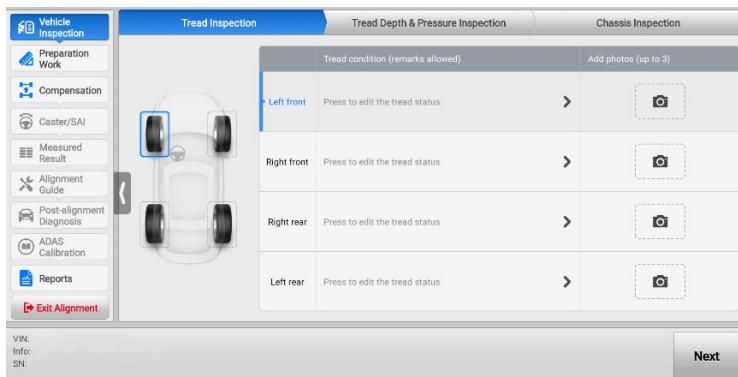

Figure 6-11 Advanced Wheel Alignment Procedure Screen

NOTE

The Advanced Wheel Alignment Application includes an additional SAS and Other Diagnosis Function compared to the Wheel Alignment application, while all other functions are identical. Therefore, the following steps for the wheel alignment function are described using the Advanced Wheel Alignment application as an example.

6.4 Wheel Alignment Procedures

6.4.1 Vehicle Inspection

Vehicle Inspection includes checking the tire tread condition and depth, adjusting the tire pressure to the vehicle's standard value, and inspecting chassis components based on fault types or vulnerability points — all of these steps are essential before performing wheel alignment, as tire abnormalities, pressure deviations, or faulty chassis parts can affect the accuracy of the test results.

IMPORTANT

Before performing wheel alignment procedures, access the settings menu via **Settings > Wheel Alignment Settings** to adjust the settings according to specific requirements and actual working conditions. All wheel alignment procedures are based on the default settings in **Wheel Alignment Settings**.

6.4.1.1 Tread Inspection

- a) Tread condition (remark allowed) column

Tap the tread status description area to select the corresponding status for each

tread and add notes if needed. Then tap **OK** and check the color indicator of the four tires. If any tire indicator is red or yellow on the screen, replace or repair the tire according to the actual condition.

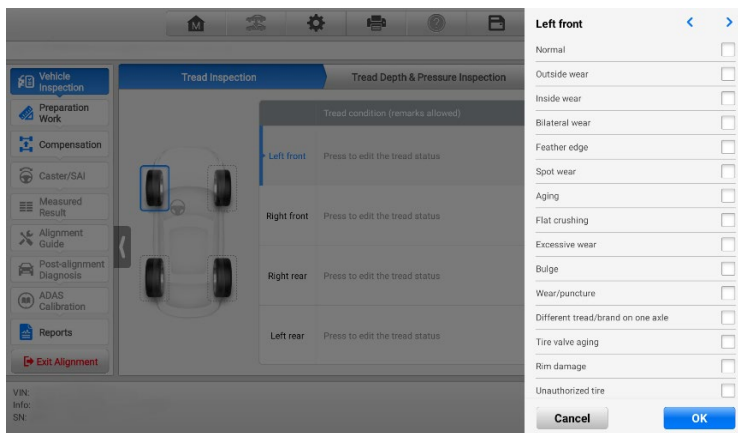

Figure 6-12 Tread Condition Screen

b) Add photos column

For better tread condition evaluation, tap the camera icon in the **Add Photos** column to add up to three photos per tread.

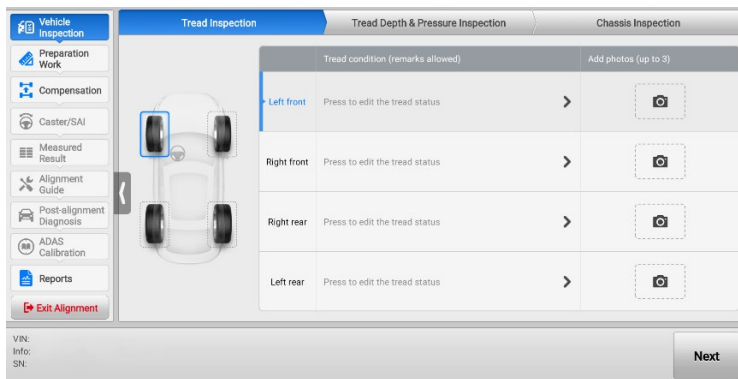

Figure 6-13 Tread Inspection Screen

6.4.1.2 Tread Depth & Pressure Inspection

Tap **Tread Depth & Pressure Inspection** to check the tread depth and pressure.



Figure 6-14 Tread Depth & Pressure Inspection Screen 1

1. Tread Depth Inspection

- a) Two modes are available for tread depth measurement: All Tread Check and Single Check. Tap **All Tread Check** or **Single Check** to switch the measurement mode.
 - All Tread Check: Measures the tread depth at three positions, including outside, middle, and inside of the tire (close to the vehicle body).
 - Single Check: Measures the tread depth at one of the following positions: outside, middle, or inside of the tire (close to the vehicle body).
- b) A tread depth measurement tool — such as the Autel MaxiTPMS TBE series device (hereinafter referred to as the **TBE device**) — is required for tread depth measurement. If you use the TBE device, the measured values will be automatically displayed in the corresponding input box; if using other tools, manually enter the values into the corresponding input box.

NOTE

After entering all the tread depth values and tread pressure values, check the color indicators of the four tires on the screen, and replace or repair the tire according to the actual condition.

When using the MaxiTPMS TBE200 (not included; contact the local dealers for purchase)

for tread depth measurement, connect the device to the tablet, and the tablet will automatically recognize and upload the tread depth data. The data can also be synchronized by pressing the **Load Tread Data** button.

Tap the blue **Connect Tread Measuring Tool** button and follow the on-screen prompts to pair the TBE device with the tablet. Alternatively, refer to [Connect Tread Measuring Tool](#) to achieve the connection prior to performing the wheel alignment function.

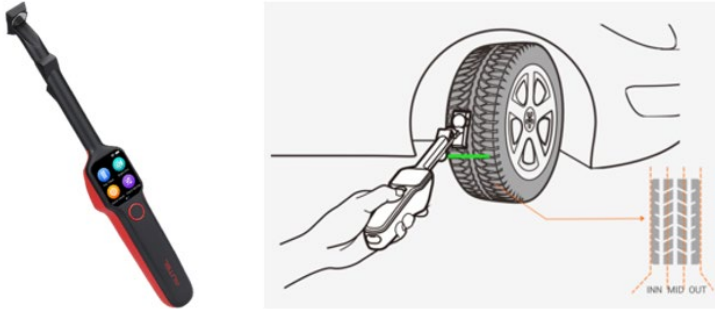

Figure 6-15 MaxiTPMS TBE Device and Use Diagram

2. Tread Pressure Inspection

- a) Input the standard tread pressure into the corresponding input box. The standard tire pressure is found on the tire and loading information placard, normally located on the B-pillar.

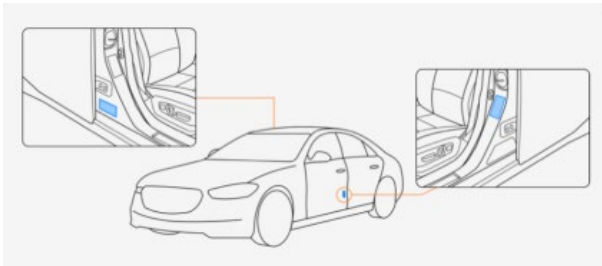

Figure 6-16 Standard Tire Pressure Value Location

- b) A tire pressure measurement tool — such as the Autel ITS600 series device (hereinafter referred to as the ITS600 device) — is required for tire pressure

measurement. If you use the ITS600 device, the measured values will be automatically displayed in the corresponding input box; if using other tools, manually enter the values into the corresponding input box.

When using the ITS600 device (not included; contact the local dealers to purchase) for tire pressure measurement, connect the device to the tablet, and the tablet will automatically recognize and upload the tire pressure data. The data can also be synchronized by pressing the **Load Pressure Data** button.

Tap the blue **Connect Tire Pressure Measuring Tool** button and follow the on-screen prompts to pair the TBE device with the tablet. Alternatively, refer to [Select Tire Pressure Measuring Device](#) to achieve the connection prior to performing the wheel alignment function.

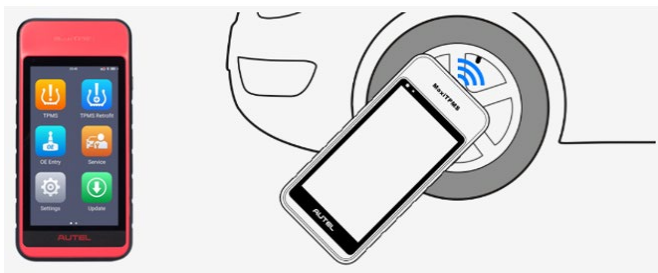

Figure 6-17 ITS600 Device and Use Diagram



Figure 6-18 Tread Depth & Pressure Inspection Screen 2

6.4.1.3 Chassis Inspection

Chassis inspection enables quick and accurate troubleshooting of chassis component

faults and records the inspection process.

Chassis inspection covers eight systems listed in the right-hand column, each with multiple subdivided inspection items. Follow the on-tablet operation guides to inspect all eight systems sequentially, or to inspect specific items by filtering. Tap any inspection item to view the component description, associated symptoms, and repair methods in the main section.

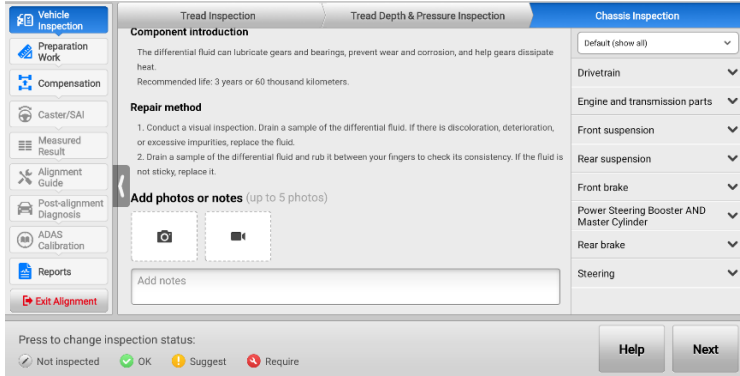



Figure 6-19 Chassis Inspection Screen 1

Tap the  icon to change the inspection status. For details about each status icon, tap the **Help** button.

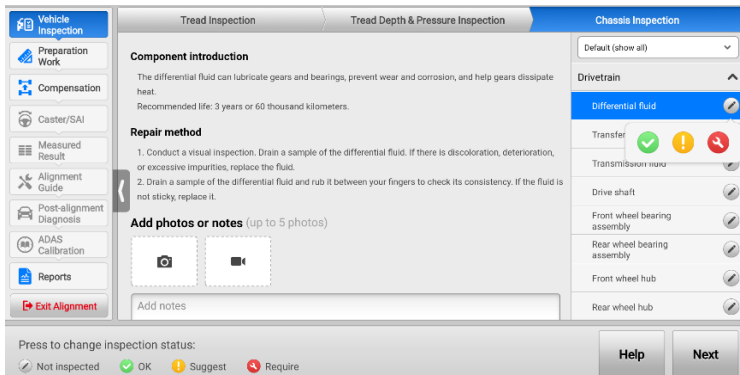

Figure 6-20 Chassis Inspection Screen 2

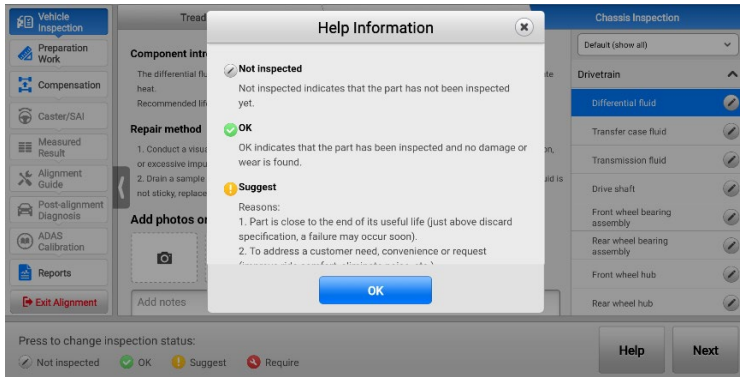



Figure 6-21 Chassis Inspection Status Icon Explanation Screen

- a) Tap the  button in the main section to capture and upload up to 5 images of the related component. Tap the  button to record and upload a 2–10-second video of the component.
- b) Tap the drop-down box in the upper right corner of the screen to display the items to be inspected, categorized by faults.

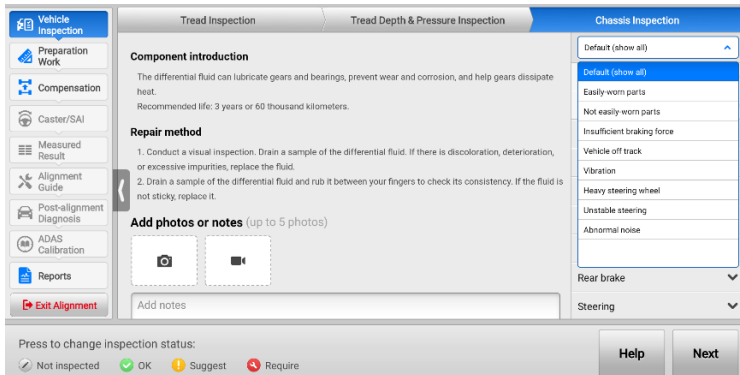

Figure 6-22 Chassis Inspection Screen 3

6.4.2 Preparation Work

For performing wheel alignment, the OE of some vehicle models has special requirements. In order to ensure the accuracy of the measurement results, the following preparations may be required before measuring the parameters related to wheel alignment.

1. Pre-alignment Notes
2. Diagnostic Functions
3. Ride Height Measurement

6.4.2.1 Pre-alignment Notes

The proper placement of the vehicle's fuel tank, spare tire, and jack in their dedicated positions is critical to accurate wheel alignment measurements. Additionally, the status of the comfort system (whether activated or deactivated) on certain vehicle models impacts the installation of the brake pedal depressor and steering wheel holder. OEMs impose strict requirements for these conditions. Therefore, it is mandatory to carefully verify the vehicle status in accordance with the pre-alignment notes before performing wheel alignment.

Pre-alignment requirements vary by vehicle model in accordance with OEM procedures. Carefully review and adhere to these requirements before operation.



Figure 6-23 Pre-alignment Notes (Sample 1)

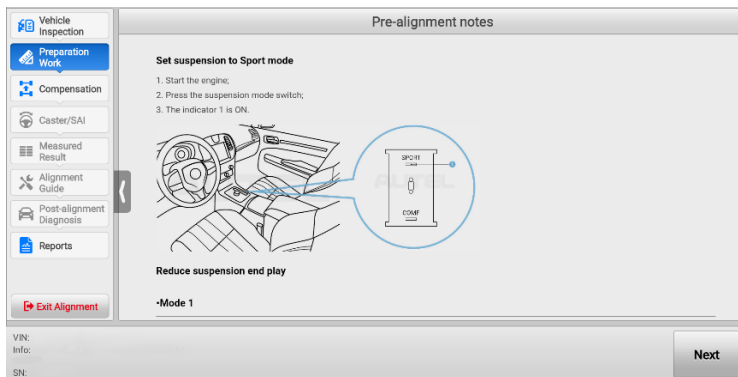

Figure 6-24 Pre-alignment Notes (Sample 2)

6.4.2.2 Diagnostic Functions

To ensure measurement accuracy and successful wheel alignment, the OE process for certain models requires relevant diagnostic functions (e.g., height adjustment, mode selection, and RDC reset) to be completed before wheel alignment parameter measurement.

NOTE

1. The diagnostic functions are only performed when you select the **Advanced Wheel Alignment** application.
2. The diagnostic functions vary by vehicle model. In the process of performing the diagnostic function, you need to read the notes carefully and follow the steps shown on the screen.

Take the ride height adjustment on BMW vehicles as an example. Ride height adjustment is required before measuring ride height in Load mode.

➤ **To perform ride height adjustment**

1. Follow the guides shown on the screen to ensure that the following conditions are met:
 - 1) The brake pedal depressor is already removed.
 - 2) The ignition is ON.
 - 3) The engine is OFF.

- 4) The VCI is connected properly.
2. If all the above conditions are met, tap **Next** to continue. Since the ride height adjustment procedure is precise and sensitive, adjustment errors can be caused by even the slightest disturbing influences acting on the vehicle, which adversely affect driving stability and comfort, so please carefully read the precautions for height adjustment and operate as required:
 - 1) The vehicle is parked with all four wheels on flat ground.
 - 2) The load status of the vehicle must not be changed.
 - 3) The vehicle is not raised or placed on a vehicle lift.
 - 4) The front wheels are in the straight-ahead position.
 - 5) The doors must not be open.
 - 6) The engine must not be started.
 - 7) The battery charger should be connected.

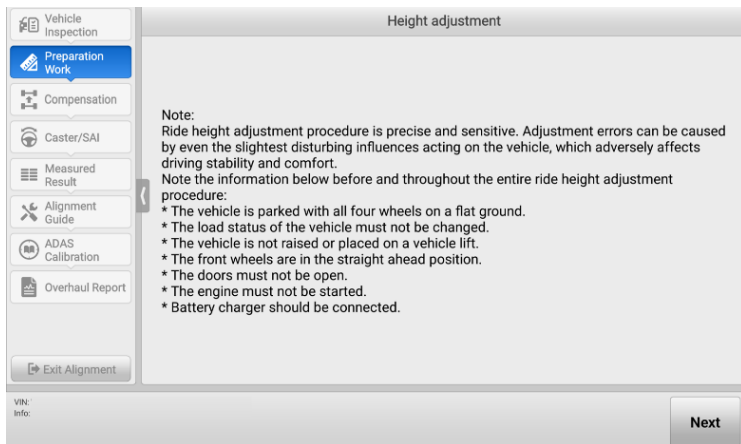

Figure 6-25 Height Adjustment Screen 1

3. Tap **Next** to continue if all the above conditions are met. The tablet will guide you to measure and enter the corresponding vehicle height value according to the actual situation.

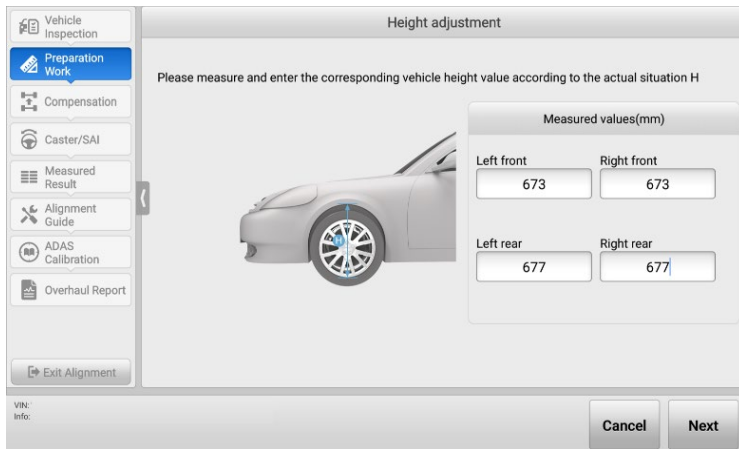

Figure 6-26 Height Adjustment Screen 2

4. After measuring and entering the vehicle height values, tap **Next** to write the values to the Vertical Dynamics Platform (VDP) control unit.



Figure 6-27 Height Adjustment Screen 3

5. Tap **Next** to continue. If the tablet displays the following screen, it indicates the ride height adjustment was successful.

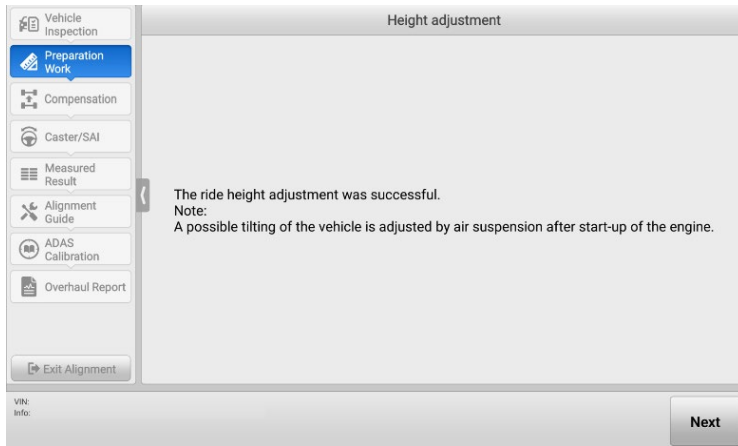

Figure 6-28 Height Adjustment Screen 4

6.4.2.3 Ride Height Measurement

The ride height measurement needs to be performed when the following conditions exist in the OE process of some vehicle models:

1. There is a standard value for the ride height.
2. The ride height value affects the standard value for wheel alignment.

NOTE

If the measured ride height value is not within the range of the standard value for ride height, you need to check if the vehicle body or the component on the chassis is deformed or damaged.

1. Measure with tape or other tools
 - a) For vehicles (e.g., Volkswagen) with a standard ride height, use a tape measure or other tools to measure the ride height, and enter the values into the corresponding input box.

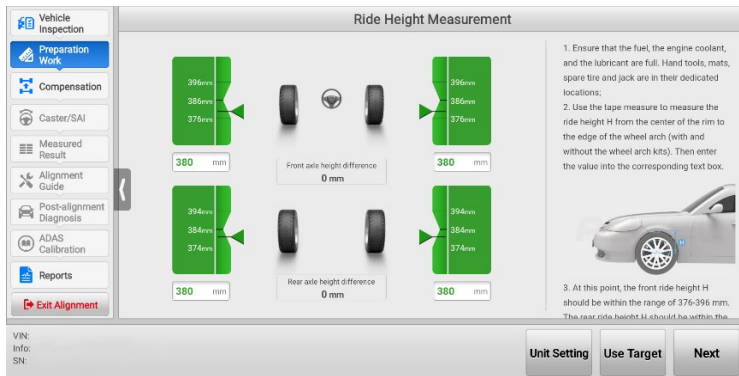

Figure 6-29 Measure Ride Height with Tape 1

- b) For vehicles (e.g., Renault) without standard values for the ride height or those requiring multiple measurements per tire, use a tape measure or other tools to measure the ride height, and enter the values into the corresponding input box.

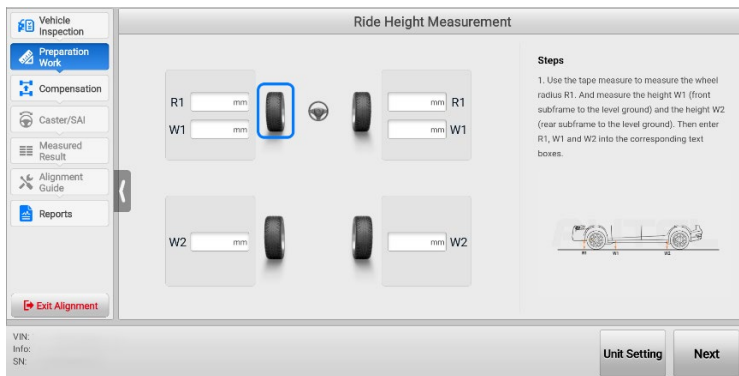

Figure 6-30 Measure Ride Height with Tape 2

2. Measure with the ride height target

The ride height can be measured with the ride height target if one of the following conditions is met:

- There is a standard value for the ride height, and the ride height is measured from the lower edge of the wheel trim to the center of the wheel rim.
- BMW vehicles, for which the ride height is measured from the lower edge of the wheel trim to the center of the wheel rim, and for which the rim size is selected before entering the whole wheel alignment procedures screen.

NOTE

- A dedicated ride height target to measure the ride height is required, and can be purchased by contacting the local dealer or manufacturer.
- After measuring the ride height, be careful to remove the ride height target to avoid vehicle body damage.

➤ To install a ride height target for ride height measurement

1. Follow the guide shown on the screen: install the wheel clamps (rim clamps), wheel targets, and ride height targets after ensuring the distance between the frame and the front wheel center is within 2.03–3.30 m (7.23–10.83 ft).

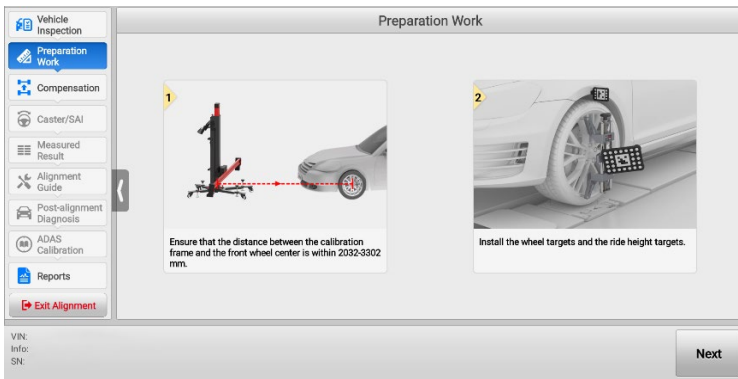

Figure 6-31 Preparation Work

2. Tap **Next** to enter the following screen. The crossbar height will be automatically adjusted to search for the targets. The ride height value will automatically display in the corresponding input box.

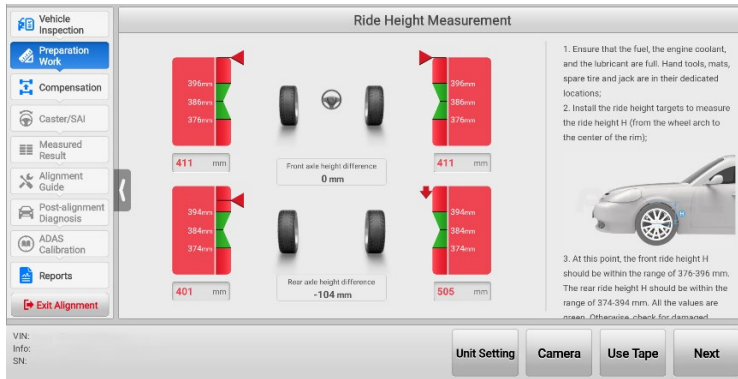

Figure 6-32 Measure Ride Height with Ride Height Target

3. Indicated by Tilt Angles

For vehicles (e.g., Mercedes-Benz), the ride height is indicated by the tilt angles. Use the Inclination Sensor (for Mercedes-Benz) to measure the tilt angles of the corresponding chassis components, and enter the tilt angles into the corresponding input box.

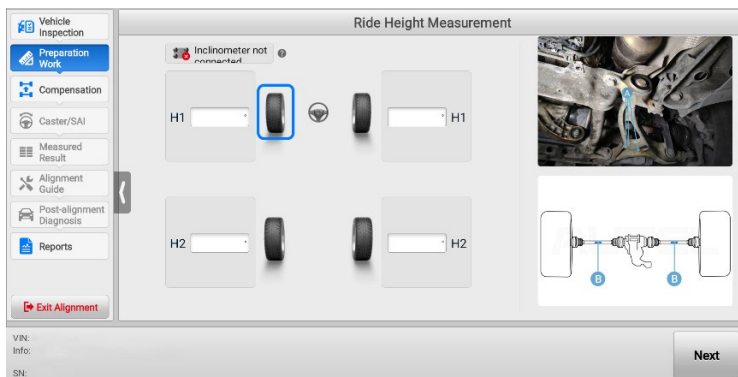

Figure 6-33 Measure and Input Tilt Angles

When using the hand-held inclinometer (not included; contact the local dealers to purchase) for ride height measurement, connect the device to the tablet as shown in the picture below. Press **OK** to measure the tilt angle. The hand-held inclinometer will automatically upload the data to the tablet.

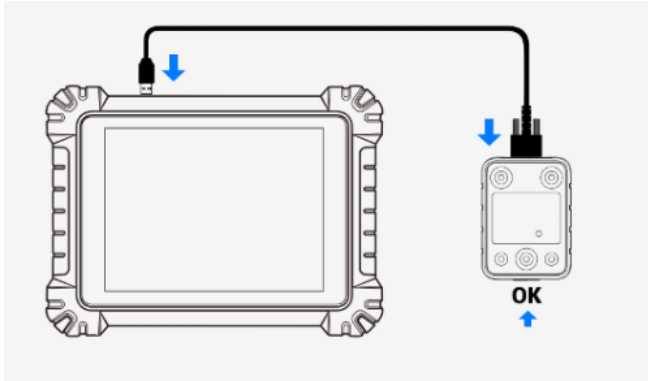

Figure 6-34 Connect Hand-held Inclinometer

6.4.3 Compensation

This function is mainly used to compensate for errors caused when installing tools such as the wheel clamp (rim clamp/tire clamp) and target.

NOTE

- If the wheel clamp (rim clamp/tire clamp) or target is removed or loosened during compensation, it will result in inaccurate measurement results. In this case, perform the compensation again.
 - Do not obstruct the target during the compensation.
-

6.4.3.1 Rolling Compensation

1. Follow the guides shown on the tablet to complete the following preparations:
 - Insert turnplate/slip plate pins and install the turnplate bridge.
 - Drive the vehicle on the alignment rack and place the wheel chocks to prevent movement.
 - Steer ahead, lock the steering wheel, place the transmission in neutral, and release the parking brake.
 - Install the wheel clamps (rim clamps) and targets (if not previously installed).

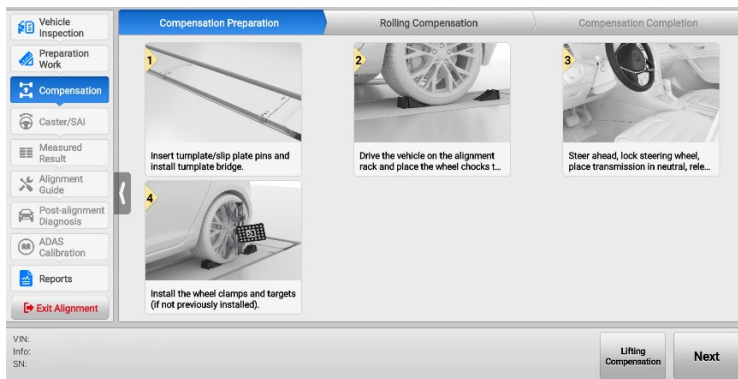

Figure 6-35 Rolling Compensation Preparations (Use Rim Clamp)

NOTE

When driving the vehicle onto the lift, the width from the turntable bridge to each wheel should be the same, and the front wheel of the vehicle should stop at the center of the turnplate.

2. Tap **Next**. The crossbar height will be adjusted automatically to search for the targets. Then follow the guides shown on the tablet to push the vehicle backward and forward to complete compensation.

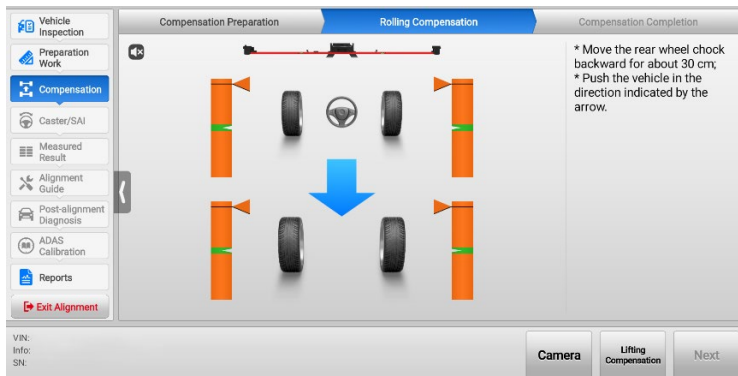

Figure 6-36 Start Rolling Compensation 1 (Use Rim Clamp)

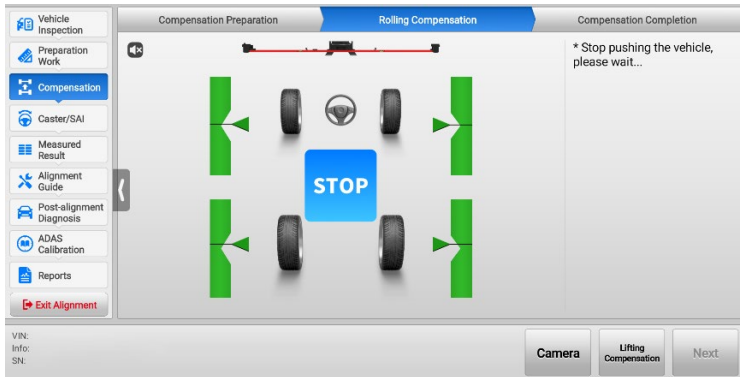

Figure 6-37 Start Rolling Compensation 2 (Use Rim Clamp)

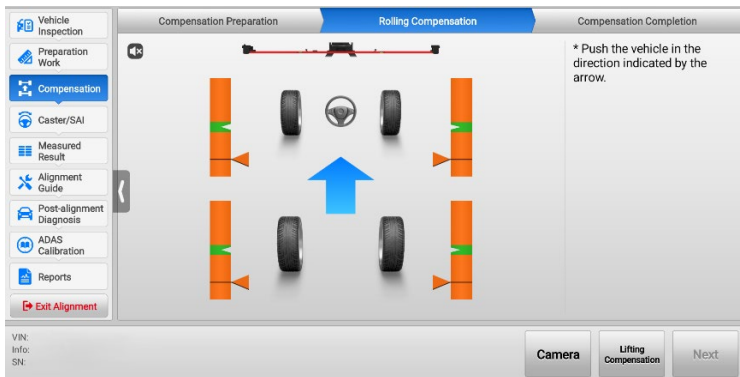

Figure 6-38 Start Rolling Compensation 3 (Use Rim Clamp)

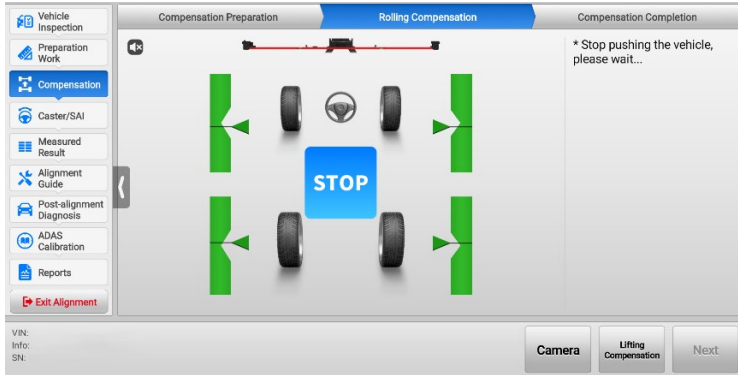

Figure 6-39 Start Rolling Compensation 4 (Use Rim Clamp)

NOTE

Do not touch the wheel clamps and targets when pushing the vehicle.

- After the compensation is completed, the tablet will enter the next screen automatically. Follow the illustration shown on the tablet to place wheel chocks in the front and rear of the wheel to prevent wheel movement.

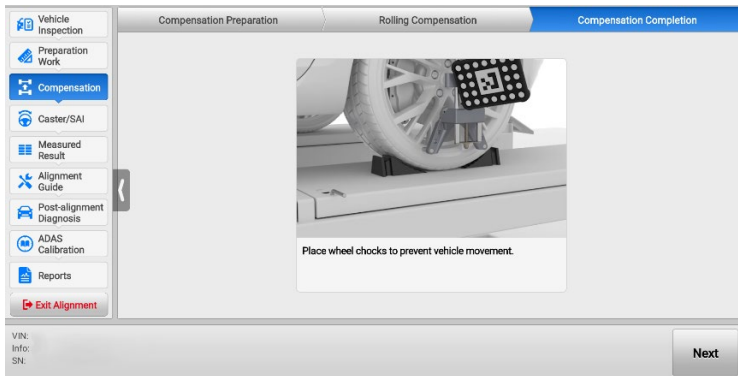

Figure 6-40 Complete Rolling Compensation (Use Rim Clamp)

6.4.3.2 Lifting Compensation

- Follow the guides shown on the tablet to complete the preparations:

- Steer ahead, lock the steering wheel, place the transmission in neutral, and release the parking brake.
- Raise the vehicle.
- Install the wheel clamps (rim clamps) and targets (if not previously installed).

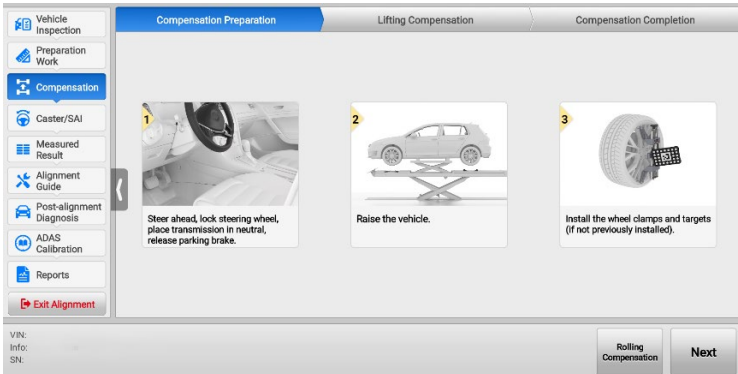

Figure 6-41 Lifting Compensation Preparation (Use Rim Clamp)

2. Tap **Next**. The crossbar height will be adjusted automatically to search for the targets. Then follow the guides shown on the tablet to rotate the tire to the collection range.

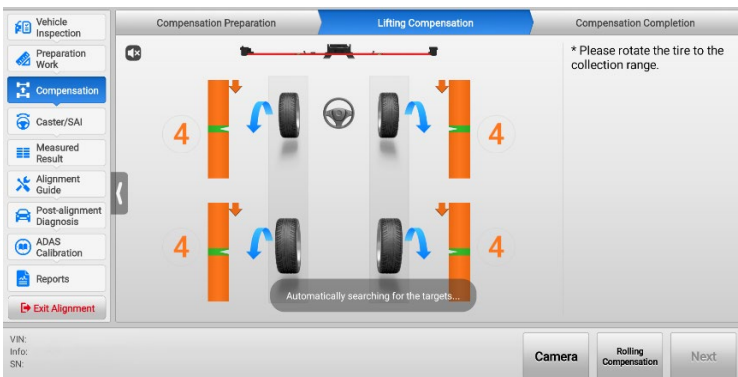

Figure 6-42 Start Lifting Compensation 1 (Use Rim Clamp)

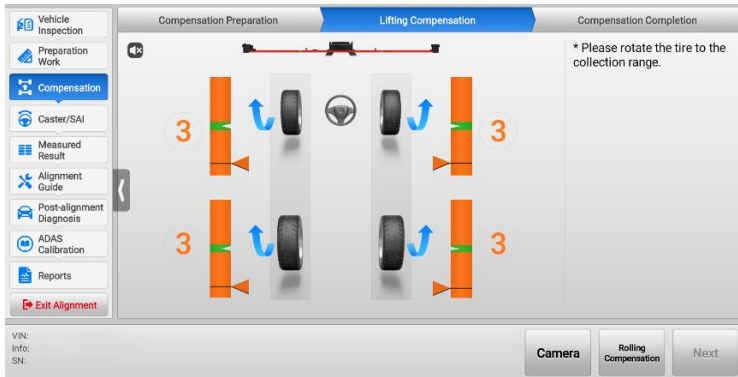

Figure 6-43 Start Lifting Compensation 2 (Use Rim Clamp)

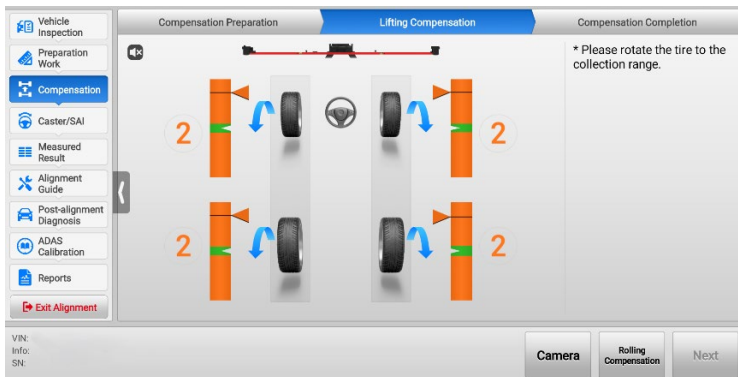

Figure 6-44 Start Lifting Compensation 3 (Use Rim Clamp)

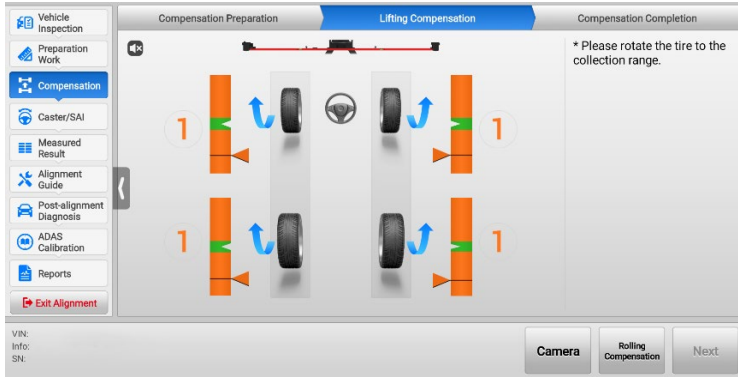

Figure 6-45 Start Lifting Compensation 4 (Use Rim Clamp)

3. After the compensation is completed, the tablet will enter the following screen automatically. Follow the guides shown on the tablet to complete the following operations:
 - Remove turnplate/slip plate pins and remove turnplate bridge.
 - Lower the wheels and jounce the vehicle.
 - Place wheel chocks to prevent vehicle movement.

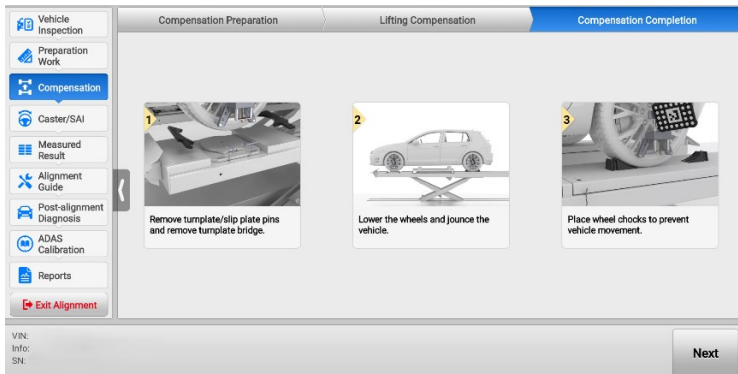



Figure 6-46 Complete Lifting Compensation (Use Rim Clamp)

 **NOTE**

- Make sure the four targets installed on the wheels are level before lowering the vehicle. If the targets are not level, both subsequent measured results and wheel alignment results may be adversely affected.
 - Before lowering the vehicle, the turnplate, slip plate pins, and turnplate bridge must be removed. Otherwise, the measurement results may be inaccurate due to the unnatural forces on the vehicle.
 - Before lowering the vehicle, shake it so that the components of the chassis are evenly stressed.
-

6.4.4 Caster/SAI/IA Angle Measurement

This function guides measuring the Caster angle, SAI (Steering Axis Inclination) angle, IA (Included Angle) angle, toe-out on turns, and maximum steering angle. Measuring these angles facilitates the identification of potential issues in the vehicle's front suspension and steering system.

6.4.4.1 *Select Measurement Angle*

- a) The Caster angle, SAI angle, and IA angle are measured by default.
- b) Select toe-out on turns to measure the Caster angle, SAI angle, IA angle, and toe-out on turns together.
- c) Select the maximum steering angle to measure the Caster angle, SAI angle, IA angle, and maximum steering angle together.
- d) Select both toe-out on turns and the maximum steering angle to measure the Caster angle, SAI angle, IA angle, toe-out on turns, and maximum steering angle together.



Figure 6-47 Caster/SAI/IA Measurement

6.4.4.2 Angle Measurement Preparation

Follow the guides shown on the tablet to complete the following operations:

1. Remove the steering wheel holder to ensure that the steering wheel can be turned.
2. Start the vehicle. Fully depress the brake pedal and install the brake pedal depressor. Stop the vehicle.
3. Remove turnplate/slip plate pins and remove turntable bridge.
4. Install wide-angle targets on the front wheels (This step is required only when measuring the maximum steering angle).

NOTE

- If the brake pedal depressor is installed without starting the vehicle, the brakes will not be locked properly, which may result in inaccurate measurement data.
- The measured results of toe-out on turns and maximum steering angle will be displayed in the Result Lists in the Measured Result section.

6.4.4.3 Start Angle Measurement

After the above preparations are successfully made, tap **Next** to start angle measurement. Then follow the guides shown on the tablet to turn the steering wheel left or right within the collection range step by step. Once the measurement procedures are completed, the system will enter the Measured Result section automatically.

6.4.5 Measured Result

This section enables the following functions:

1. View measured results for toe, camber, caster, symmetry value, rolling angle, etc.
2. View and modify wheel specifications.

6.4.5.1 Graphical Result



Figure 6-48 Measured Result Screen (Graphical Result)

- a) Tap the single image on the screen, and the selected image will be zoomed in.

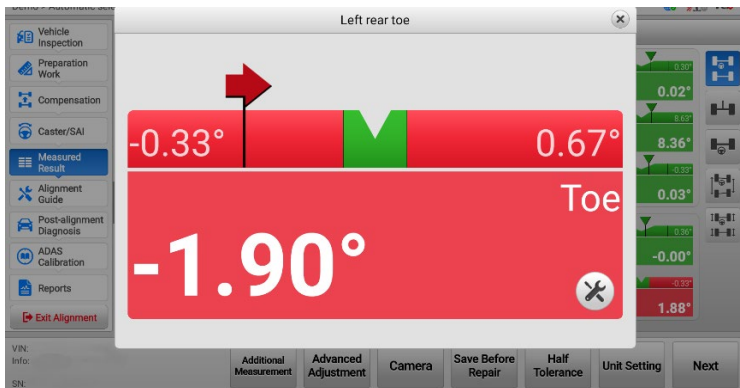





Figure 6-49 Zoom-in Image

- b) Tap the  button on the above screen to open the adjustment guide screen. The guide for the selected image will then be displayed; follow the on-screen instructions to perform adjustments. Once the adjustment is completed, tap  to exit the adjustment guide screen.
- c) Tap the buttons, such as  in the middle part of the screen, to view the Parameter Descriptions. Refer to [Glossary](#) for details.
- d) Tap the buttons, such as  on the right side of the screen, to view the Graphical Result-Rear, the Graphical Result-Front, the Graphical Result-Symmetry Value, and the Graphical Result-Rolling Diameter, respectively.
- e) Tap **Additional Measurement** to perform bump steer measurement. Refer to [Additional Measurement](#).
- f) Tap **Advanced Adjustment > Raise Vehicle** to raise the vehicle for adjustment. Refer to [Raise Vehicle](#).
- g) Tap **Advanced Adjustment > Wheel Off Adjustment** to remove the vehicle for adjustment. Refer to [Wheel Off Adjustment](#).
- h) Tap the **Camera** button to check the cameras' working condition.

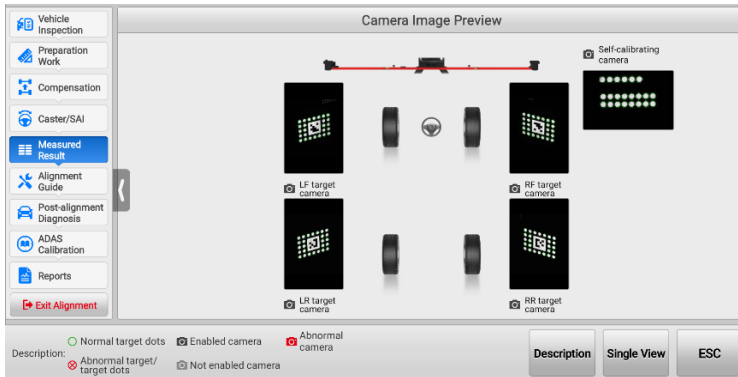

Figure 6-50 Camera Image Preview Screen

- The **Camera** button is available at any time for checking the working status of the cameras, and its functionality is not restricted to the current screen.
- Tap **Description** to check the explanations for each icon displayed on the screen. Refer to [Table 4-1 Camera Descriptions](#) for details.

- Tap **Full view** or **Single view** to switch the preview method for the camera image.
 - Tap **ESC** to exit the Camera Image Preview screen.
- i) Tap **Save Before Repair** to save the measurements before alignment. Then the tablet will prompt you and ask if you want to overwrite it.
 - j) Tap **Full Tolerance** or **Half Tolerance** to switch the graphical display mode.
 - **Full Tolerance**: equals the OE specification's tolerance.
 - **Half Tolerance**: half of the OE specification's tolerance.
 - k) Tap **Unit Setting** to switch the units.
 - l) Tap **Next** to enter the Alignment Guide section.

6.4.5.2 Additional Measurement

This function works by lifting the vehicle to simulate suspension movement during real-world driving and collects toe and camber angle data to identify potential bump steer problems.

➤ To perform a bump steer measurement

1. Tap **Additional Measurement** on the Measured Result screen to view relevant information about bump steer. Then tap **OK**.

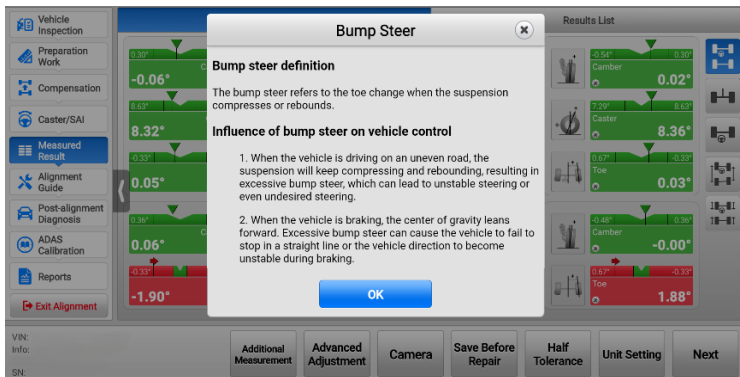

Figure 6-51 Bump Steer

2. Follow the guides shown on the tablet to prepare for the measurement.
 - 1) Steer ahead and lock the steering wheel of the vehicle.

- 2) Install the ride height target.
- 3) Remove turnplate/slip plate pins and remove turnplate bridge.

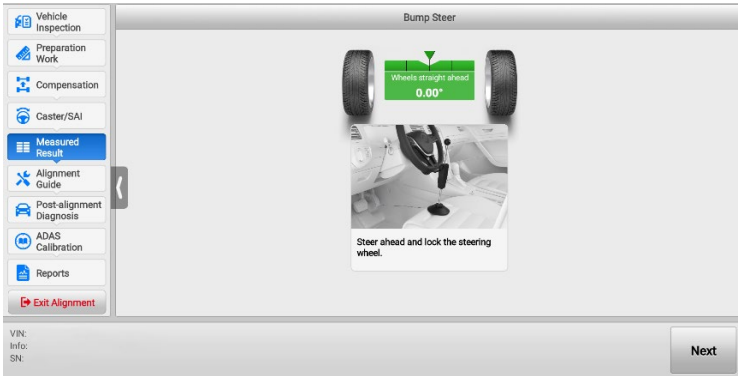

Figure 6-52 Measurement Preparation 1

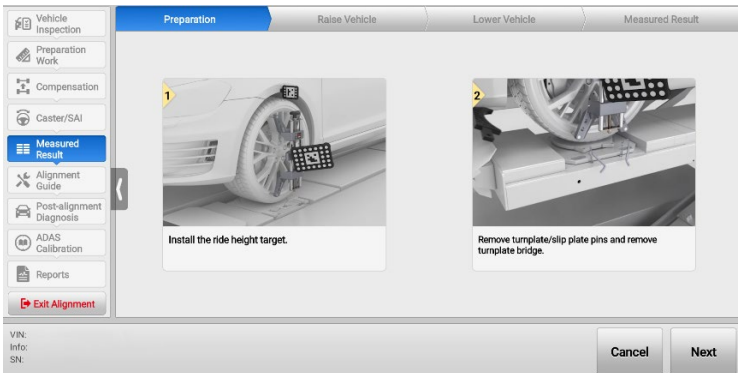

Figure 6-53 Measurement Preparation 2

3. Follow the guides shown on the tablet to raise the vehicle until the ride height falls within the green range. Once data collection is completed, the tablet will enter the vehicle lowering screen automatically.

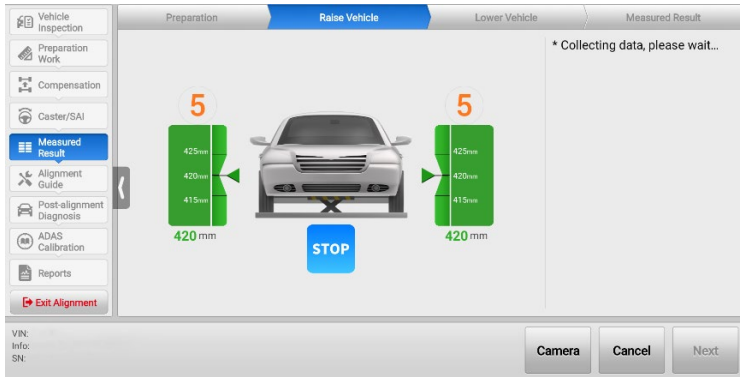

Figure 6-54 Raise Vehicle 1

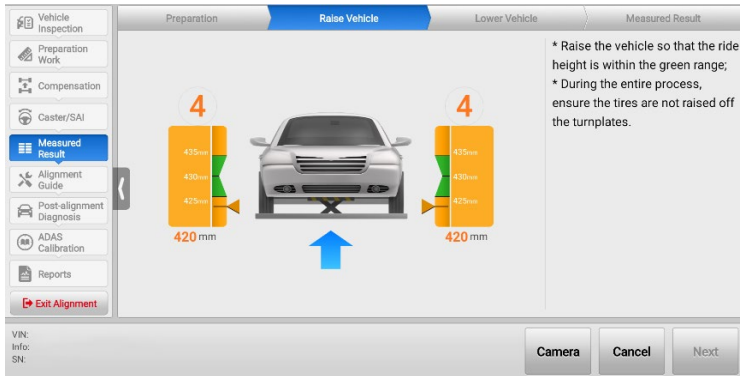

Figure 6-55 Raise Vehicle 2

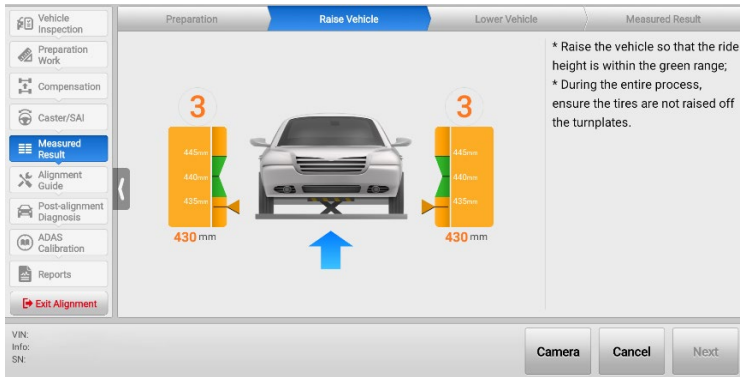

Figure 6-56 Raise Vehicle 3

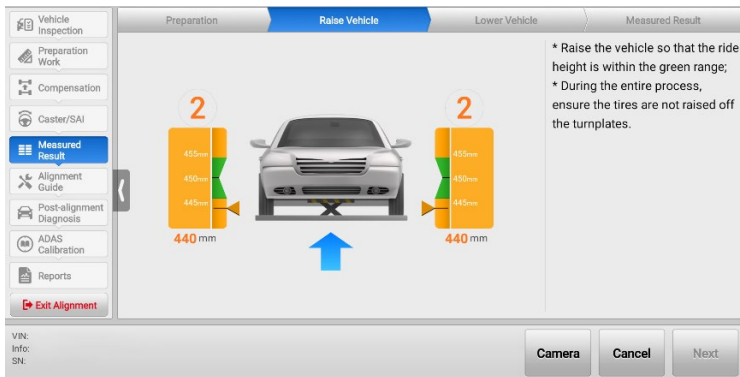

Figure 6-57 Raise Vehicle 4

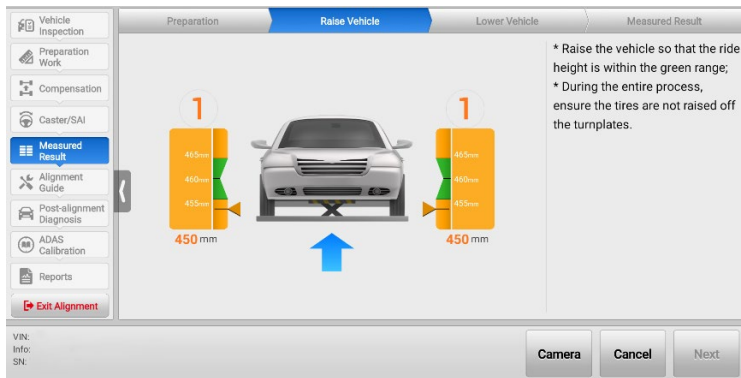

Figure 6-58 Raise Vehicle 5

4. Lower the vehicle and jounce the vehicle.

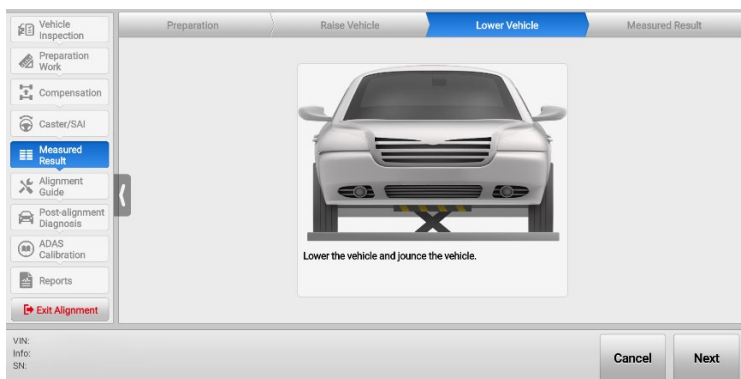

Figure 6-59 Lower Vehicle

5. Then tap **Next** to view the measured results. You can tap the **Adjustment Help** button to view adjustment suggestions and follow the guides to adjust the bump steer.

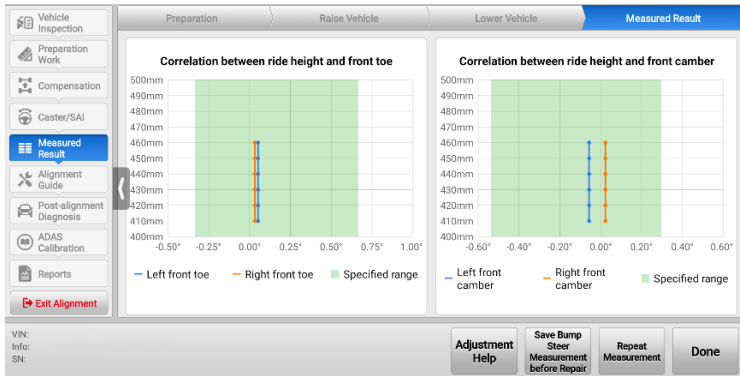

Figure 6-60 Measured Result Screen

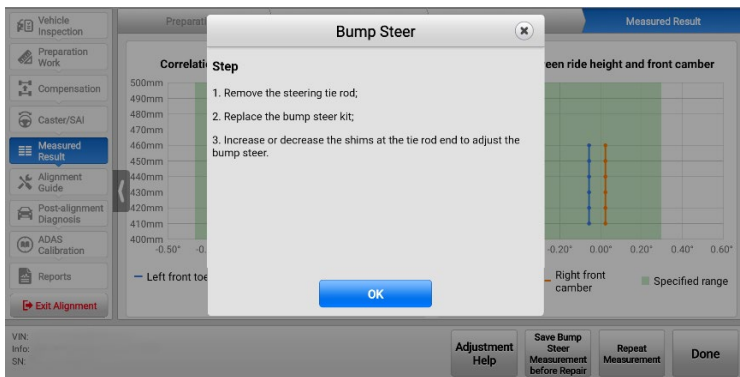

Figure 6-61 Adjustment Help Screen

6.4.5.3 Raise Vehicle

This function applies to vehicles that need to be raised to adjust the wheel alignment parameters.

➤ **To raise a vehicle**

1. Tap **Advanced Adjustment > Raise Vehicle** on the Measured Result screen.
2. Follow the guides shown on the tablet to raise the vehicle:
 - 1) Set the steering wheel at center position. Lock the steering wheel.
 - 2) Start the engine, install the brake pedal depressor, and then stop the engine.
 - 3) Raise the vehicle and lock the lift.

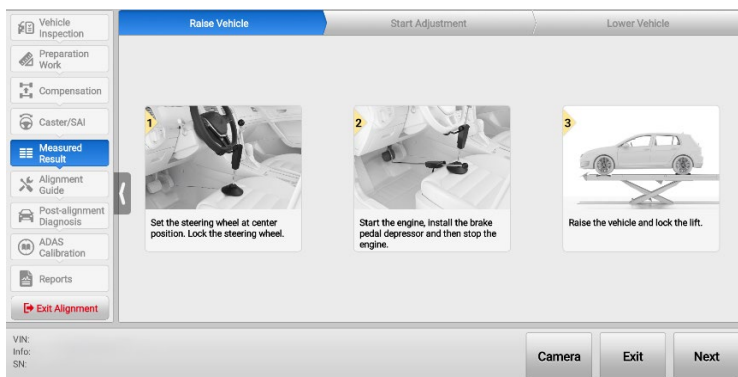

Figure 6-62 Raise Vehicle

3. After the vehicle is raised and the lift is locked, tap **Next** to collect data, and the tablet will enter the Start Adjustment screen. Tap **Next** to perform the adjustment, and the tablet will enter the Lower Vehicle screen automatically.

➤ **To lower the vehicle**

1. Lower the vehicle as shown in the guides on the screen.
 - 1) Remove turnplate/slip plate pins and remove turnplate bridge.
 - 2) Lower the wheels and jounce the vehicle.
 - 3) Place wheel chocks to prevent vehicle movement.

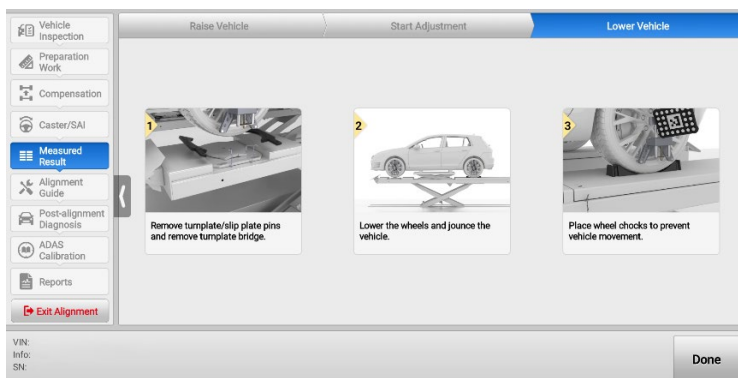

Figure 6-63 Lower Vehicle

2. After lowering the vehicle, tap **Done**. The tablet will return to the Measured Result screen.

6.4.5.4 *Wheel Off Adjustment*

This function applies to vehicles that need to have their wheels removed to adjust the wheel alignment parameters.

➤ **To raise a vehicle**

1. Tap **Advanced Adjustment > Wheel Off Adjustment** on the Measured Result screen.
2. Follow the guides shown on the tablet to raise the vehicle:
 - 1) Set the steering wheel to the center position. Lock the steering wheel.
 - 2) Start the engine, install the brake pedal depressor, and then stop the engine.
 - 3) Raise the vehicle and lock the lift.

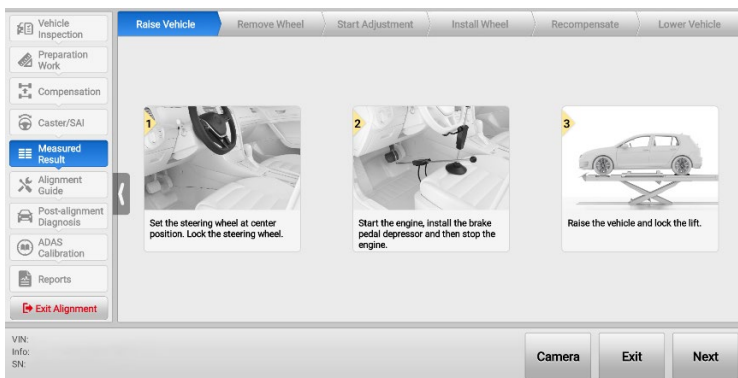

Figure 6-64 Raise Vehicle

3. After the vehicle is raised and the lift is locked, tap **Next** to collect data. Then the tablet will enter the Remove Wheel screen.

➤ **To remove the wheel**

1. After raising the vehicle, follow the guides on the screen to remove the wheels:
 - 1) Remove the wheel clamps (rim clamps) and targets.
 - 2) Remove the wheels.

3) Install the hub adapters and targets.

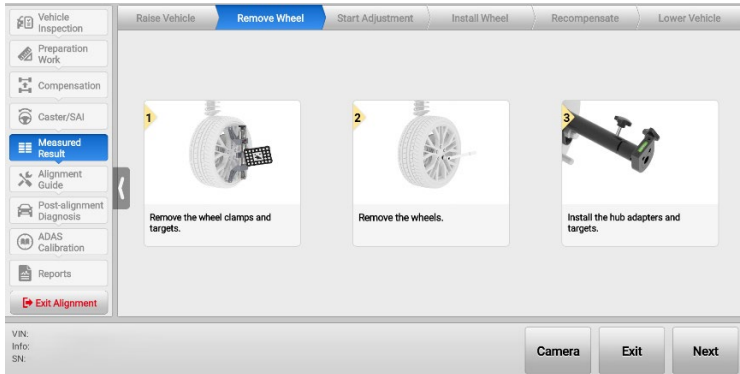

Figure 6-65 Remove Wheel

2. After the wheels are removed, tap **Next** to collect data, and the tablet will enter the Start Adjustment screen. Tap **Next** on the screen to perform the adjustment, and the tablet will enter the Install Wheel screen automatically.

➤ **To install the wheel**

1. Install the wheels as shown in the guides on the screen:
 - 1) Remove the targets and hub adapters.
 - 2) Install the wheels.
 - 3) Install the wheel clamps (rim clamps) and targets.
 - 4) Remove the brake pedal depressor.

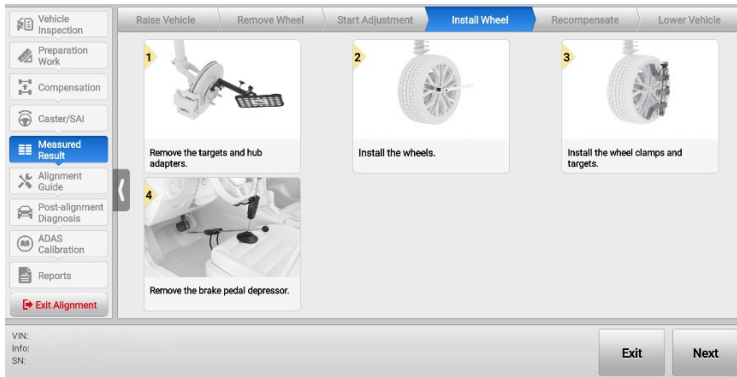

Figure 6-66 Install Wheel

2. After the wheels are installed, tap **Next** to enter the Recompensate screen.

➤ **To perform lifting recompensation**

1. The crossbar height will be adjusted automatically to search for the targets. Then follow the guides shown on the tablet to rotate the tire to the collection range.

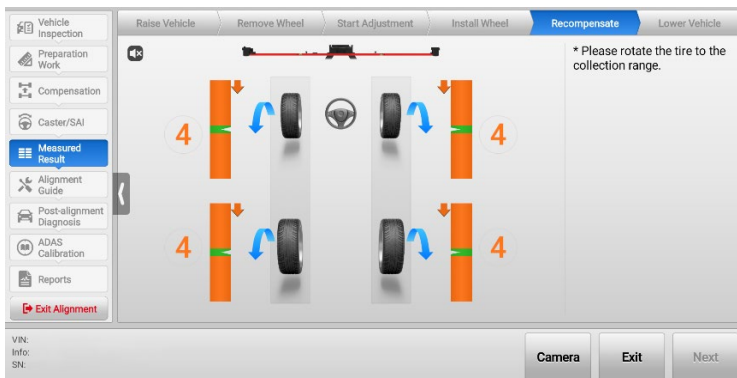

Figure 6-67 Start Lifting Compensation 1

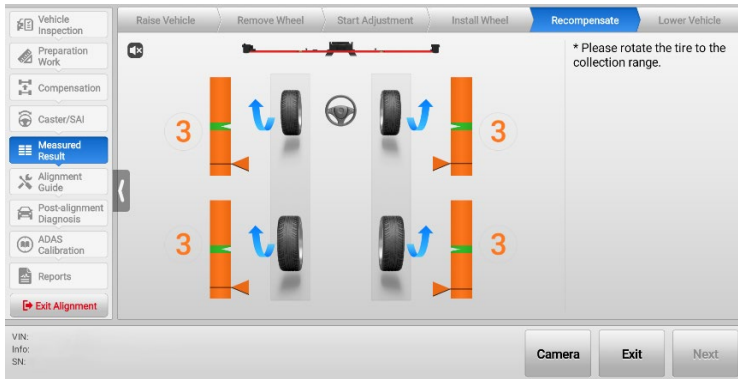

Figure 6-68 Start Lifting Compensation 2

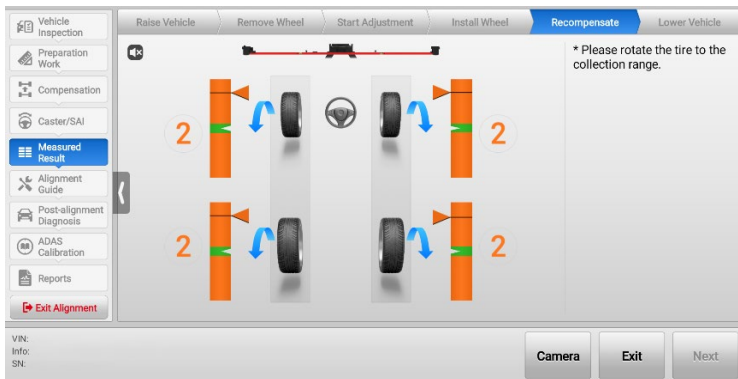

Figure 6-69 Start Lifting Compensation 3

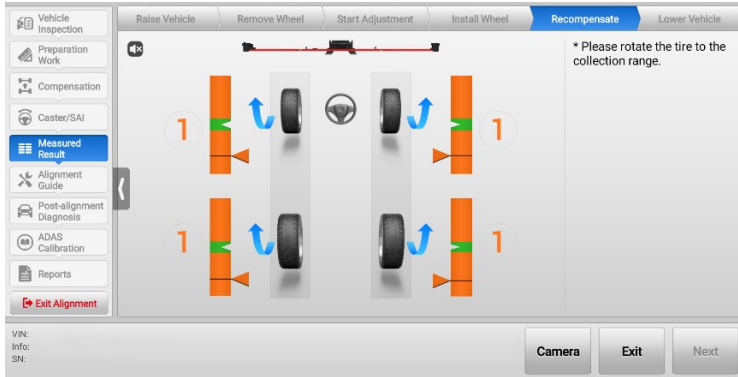

Figure 6-70 Start Lifting Compensation 4

2. After the collection is completed, the tablet will enter the Lower Vehicle screen.

➤ **To lower the vehicle**

1. Lower the vehicle as shown in the guides on the screen:
 - 1) Install the brake pedal depressor.
 - 2) Remove turnplate/slip plate pins and remove turnplate bridge.
 - 3) Lower the wheels and jounce the vehicle.
 - 4) Place wheel chocks to prevent vehicle movement.

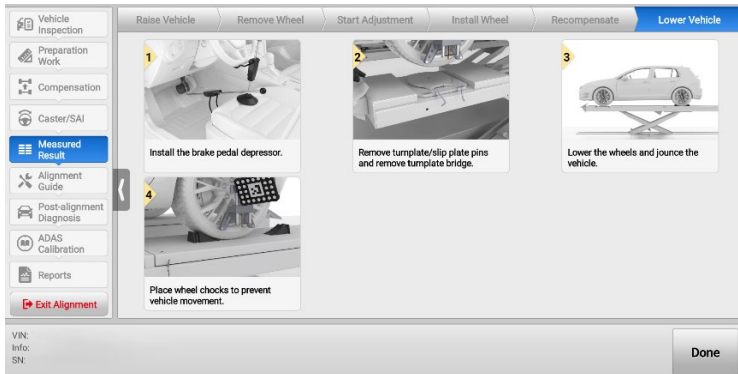

Figure 6-71 Lower Vehicle

2. After lowering the vehicle, tap **Done**, and the tablet will return to the Measured Result screen.

6.4.5.5 Results List

The results can also be displayed in a list format. You can save the list before wheel alignment.

Vehicle Inspection	Graphical Result		Results List		
	Left	Right	Front axle	Measured	
Preparation Work			Total toe	0.08°	
Compensation	Toe	0.05°	0.03°		
Caster/SAI	Camber	-0.07°	0.02°	Cross camber	-0.09°
Measured Result	Caster	8.32°	8.36°	Cross caster	-0.04°
Alignment Guide	SAI	1.35°	-1.20°	Cross SAI	2.55°
Post-alignment Diagnosis	IA	1.29°	-1.18°	Set back	0.01°
ADAS Calibration	Toe-out on turns			Wheels straight ahead	0.01°
Reports	Left maximum steer			--	--
Exit Alignment	Right maximum steer			--	--
	Ride height	380 mm	380 mm	--	--
	Rear axle	Left	Right	Rear axle	Measured
	Toe	-1.90°	1.87°	Total toe	-0.03°
	Camber	0.00°	-0.02°	Cross camber	0.02°

VIN:
Info:
SN:

Camera Save Before Repair Half Tolerance Unit Setting Next

Figure 6-72 Measured Result Screen (Results List)

6.4.6 Alignment Guide

In the Alignment Guide section, the detailed alignment procedures with illustrations on the screen make the adjustment of wheel specifications more convenient and faster.

NOTE

1. During front toe adjustment, some vehicle models support both Normal Mode and Guide Mode. The Guide Mode is enabled by default. You can tap either mode to switch between them as needed.
2. To reduce the influence of other alignment adjustments on the front caster, remeasure the caster angle before front caster adjustment.

6.4.6.1 Alignment Procedures

According to the OE process requirements, the detailed and complete alignment procedures will be provided to guide you to adjust the wheel specifications.

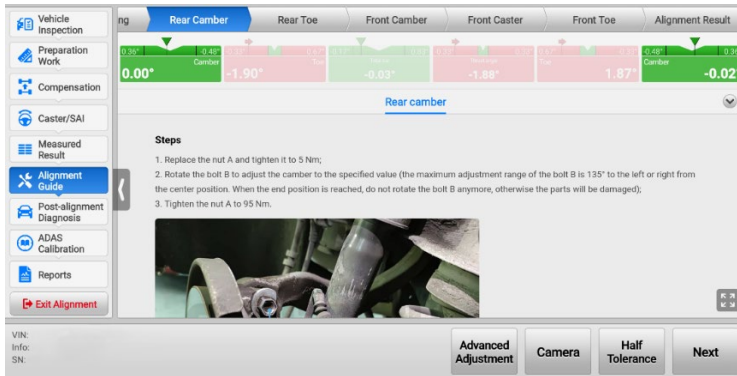

Figure 6-73 Parameters Adjustment Procedures Screen 1

- Follow the sequence displayed at the top of the main screen section to complete all wheel alignment parameter adjustments. The adjustment sequence is critical; failure to follow the specified order (Rear Camber -> Rear Toe -> Front Caster -> Front Toe -> Alignment Result) will lead to redundant operations.
- Check the highlighted red images on the screen, and perform adjustments as shown in the screen guides. Once the angle parameters are adjusted to their correct values, the red highlights will switch to green. Tap **Next** to adjust the remaining parameters using the same method.
- For certain wheel specifications, the OE process does not provide an adjustment method, and the tablet will display the interface as below.

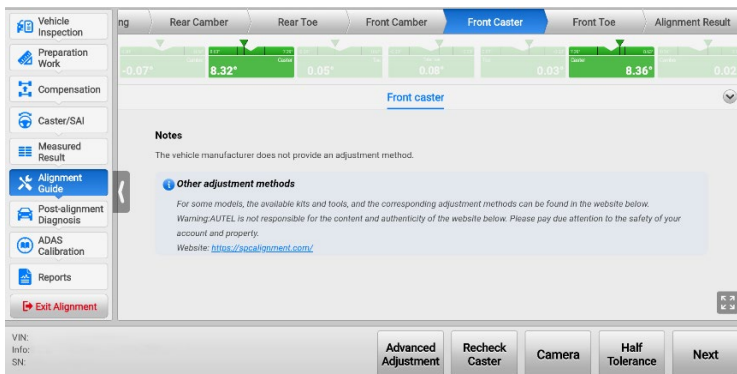

Figure 6-74 Parameters Adjustment Procedures Screen 2

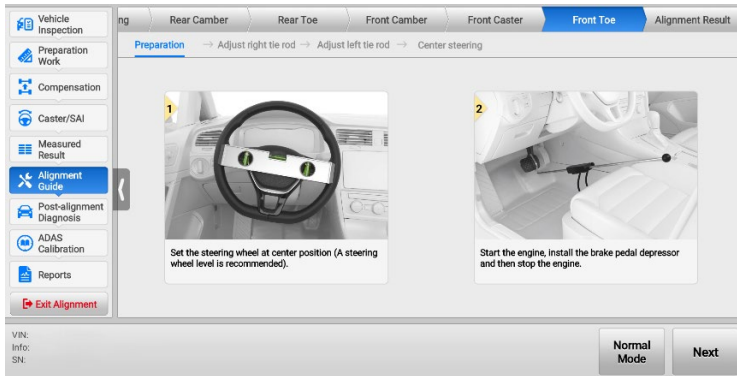

Figure 6-76 Front Toe Adjustment Preparation

2. Tap **Next** to collect data and follow the screen guides to adjust the right tie rod.
 - 1) Loosen the lock nut and adjust the right tie rod to the tolerance range.
 - 2) Jounce the front part of the vehicle to set all bottom components in their natural state.
 - 3) Tighten the lock nut.

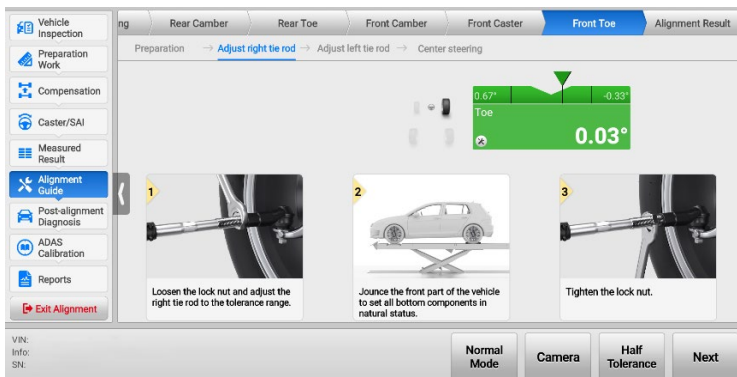

Figure 6-77 Adjust Right Tie Rod

3. Tap **Next** to collect data and then enter the left tie rod adjustment guide screen.
 - 1) Loosen the lock nut and adjust the left tie rod to the tolerance range.

- 2) Jounce the front part of the vehicle to set all bottom components in their natural state.
- 3) Tighten the lock nut.

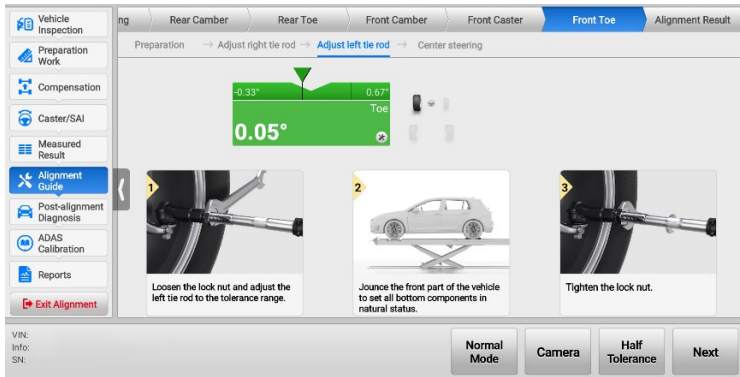

Figure 6-78 Adjust Left Tie Rod

4. Tap **Next**. Then follow the guides shown on the tablet to set the wheels straight ahead. If the steering wheel is not centered, tap **Readjust** to adjust the front toe again.

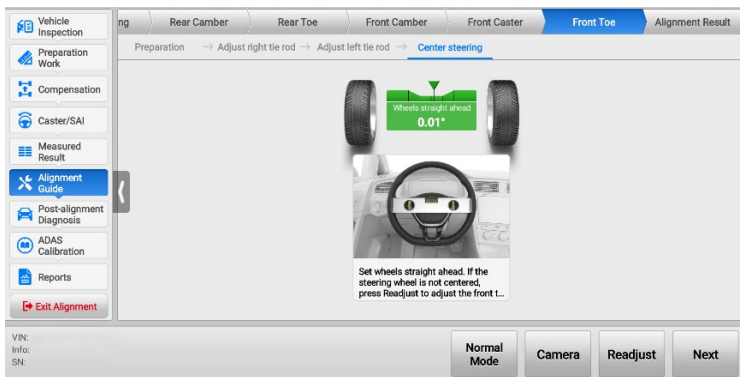

Figure 6-79 Center Steering

6.4.6.3 Recheck Caster

In some OE manuals, the caster angle must be rechecked after front caster adjustment to ensure it falls within the standard range. When rechecking, neither the crossbar nor the vehicle should be raised or lowered.

➤ **To recheck the caster**

1. Tap **Recheck Caster** on the Front Caster screen. Follow the screen guides to complete the following operations:
 - 1) Remove the steering wheel holder stand tool to ensure that the steering wheel can be turned.
 - 2) Start the vehicle. Fully depress the brake pedal and install the brake pedal depressor. Stop the vehicle.
 - 3) Remove the turnplate/slip plate pins and remove the turnplate bridge.

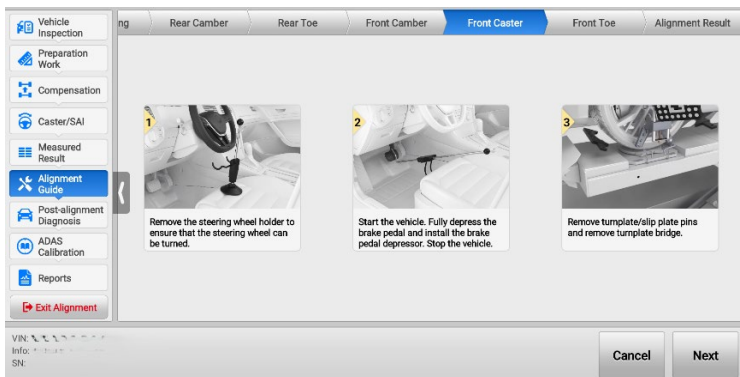

Figure 6-80 Recheck Caster Preparations

2. After completing the above preparations, tap **Next** to enter the next screen.
3. Then turn the steering wheel left or right within the collection range. Once centered, stop, and the tablet will automatically return to the Front Caster screen.



Figure 6-81 Steering Wheel Adjustment

6.4.7 Post-alignment Diagnosis

Some vehicles need to perform related diagnostic functions after the wheel alignment parameters are adjusted, such as SAS reset.

6.4.7.1 Steering Angle Sensor (SAS) Reset

After adjusting the thrust angle and toe angle, a SAS reset is required under some circumstances. Failure to perform a SAS reset may affect the functionality of security systems such as VSC, ESC, and TCS.

➤ To perform a SAS reset

1. Follow the guides shown on the tablet to check if the following conditions are met:
 - 1) The ignition is ON.
 - 2) The engine is OFF.
 - 3) The VCI is connected properly.

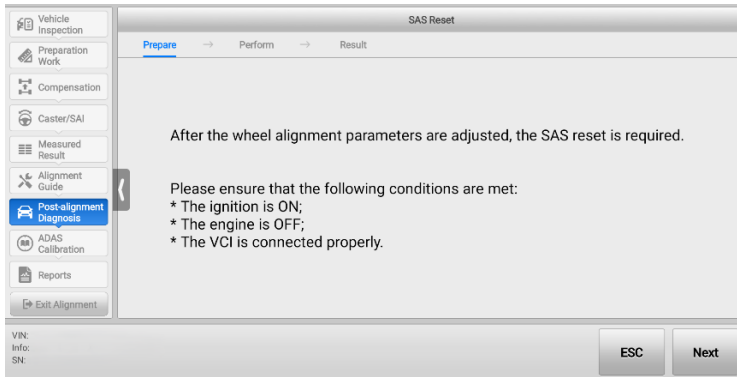

Figure 6-82 SAS Reset Screen 1

2. If the above conditions are met, tap **Next** to enter the next screen. Then follow the screen guides to turn the steering wheel slowly to the center position, set the front wheels straight ahead, and release the steering wheel.

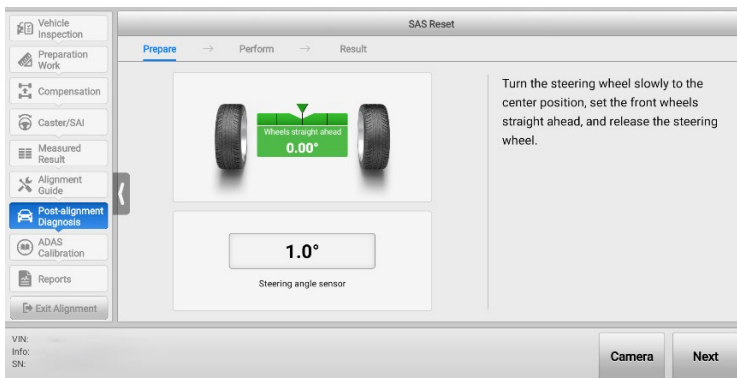

Figure 6-83 SAS Reset Screen 2

3. Tap **Next**. Follow the on-screen instructions to turn the steering wheel to the right for about 30° and then perform the following steps:
 - 1) Turn the steering wheel slowly to the left end stop and hold for about 5 s;
 - 2) Turn the steering wheel slowly to the right end stop and hold for about 5 s;
 - 3) Turn the steering wheel slowly to the center position, set the front wheels straight ahead, and release the steering wheel.

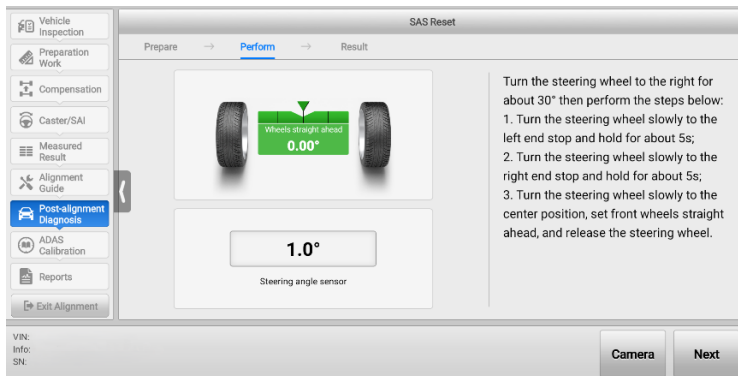



Figure 6-84 SAS Reset Screen 3

4. If the above operations are completed, tap **Next** to enter the SAS reset result screen.  indicates a successful SAS reset;  indicates a failed SAS reset.

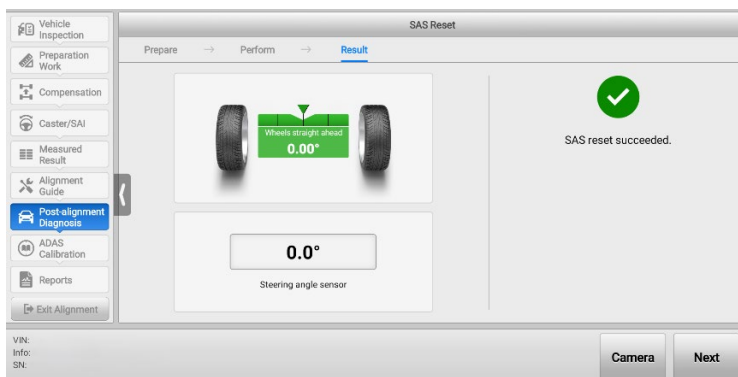

Figure 6-85 SAS Reset Screen 4

6.4.8 Reports

In this section, after performing wheel alignment, you can:

- 1) Check the Wheel Alignment Report, the wheel alignment parameters, etc.
- 2) Save reports and share reports to the cloud.

6.4.8.1 Fill in Customer Information

Before accessing the Reports section, complete the customer information. As shown in the customer information table below, the items marked with an asterisk (*) are mandatory fields that require corresponding information to be filled in.

Figure 6-86 Customer Information Table

6.4.8.2 Report Types

Ten reports can be seen if all the functions are enabled during the whole wheel alignment procedure, including reports of Chassis Safety Diagnostics, Wheel Alignment, Pre-repair & Post-repair, Pre-repair, Current Values, Symmetry Value, Chassis Inspection, Tire Inspection, Ride Height, and Bump Steer.

- 1) Chassis Safety Diagnostic Report: Inspection items, including tread, tread depth, chassis, and the four-wheel conditions; repair suggestions according to the inspections.

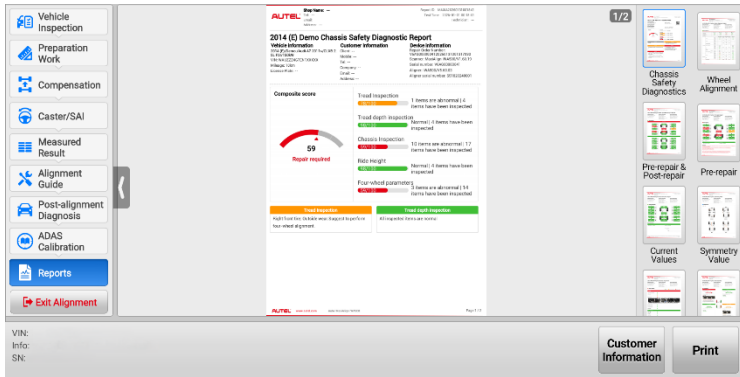

Figure 6-87 Chassis Safety Diagnostic Report

- 2) Wheel Alignment Report: All inspection results, including tread depth, tire pressure, rolling diameter, ride height, and front and rear axle specifications.

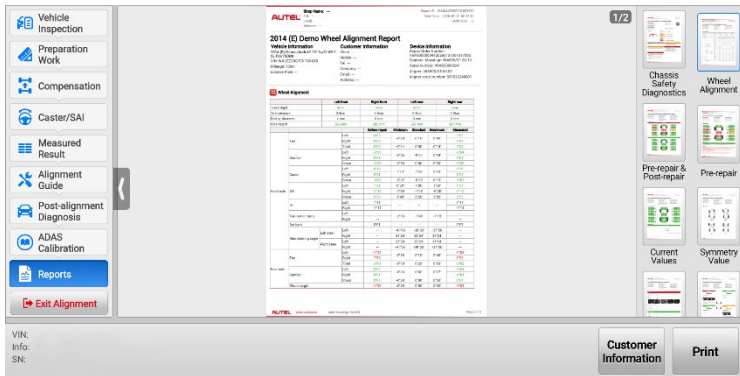

Figure 6-88 Wheel Alignment Report

NOTE

- The tread depth values and tire pressure values are available only when the tread depth & pressure inspection is performed.
- The ride height values are available only when the ride height measurement is performed.

- 3) Pre-repair & Post-repair Report: A comparative graph of pre-repair and post-repair results.

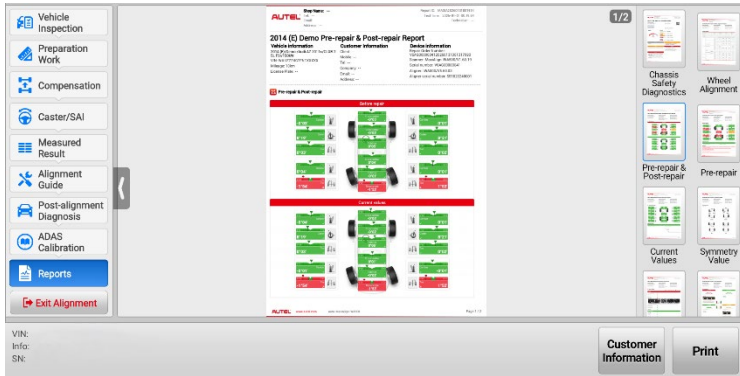

Figure 6-89 Pre-repair & Post-repair Report

- 4) Pre-repair Report: A graph of pre-repair results. Additional symptom descriptions will be provided if any of the measured values deviate from the specification values.

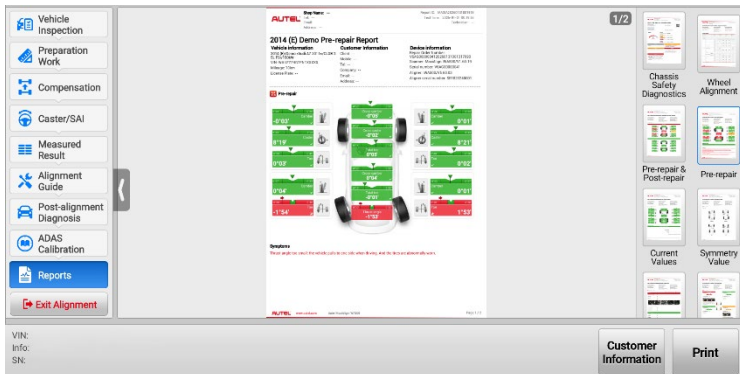

Figure 6-90 Pre-repair Report

- 5) Current Value Report: A graph of current wheel alignment results. Additional symptom descriptions will be provided if any of the current values deviate from the specification values.

- 7) Chassis Inspection Report: Record chassis inspection data. This report is only available if the chassis inspection has been performed.

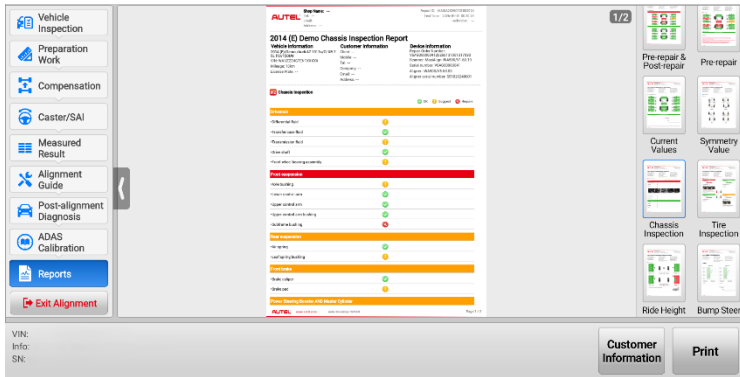

Figure 6-93 Chassis Inspection Report

- 8) Tire Inspection Report: Record the check data of tread condition, tread depth, and tire pressure. This report is available only if the tread depth & pressure inspection has been performed.

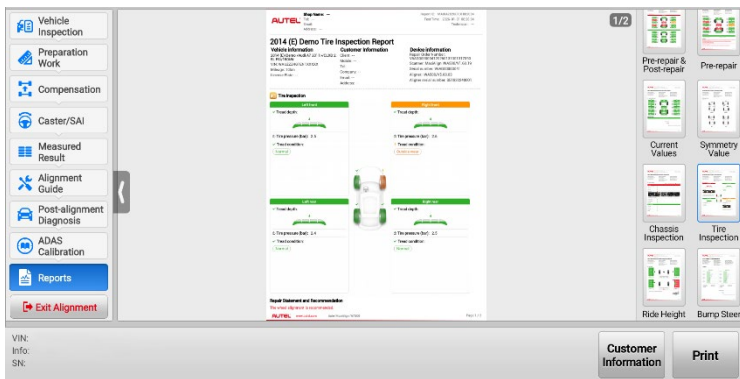

Figure 6-94 Tire Inspection Report

- 9) Ride Height Report: A graph of ride height or ride height difference. This report is available only if the ride height measurement has been performed.



Figure 6-95 Ride Height Report

- 10) Bump Steer Report: Two graphs illustrating the correlation between ride height and front toe, and between ride height and front camber, respectively. This report is only available if the bump steer measurement has been performed.

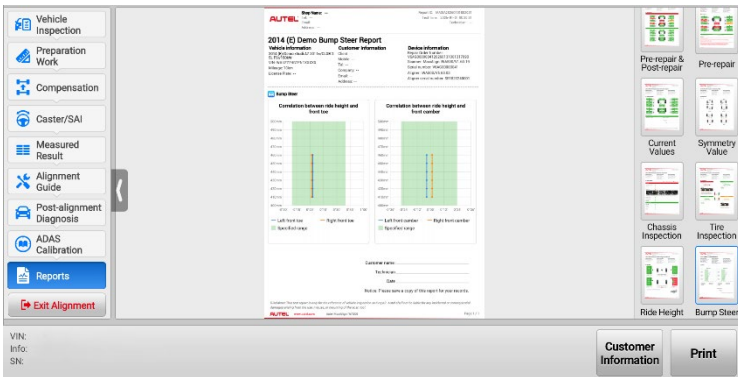



Figure 6-96 Bump Steer Report

If a report displays the  icon and no measurement data appear when tapped to view, it indicates the corresponding function has not been performed. You may tap the procedure button on the left to perform the function; the corresponding report data will then be generated.

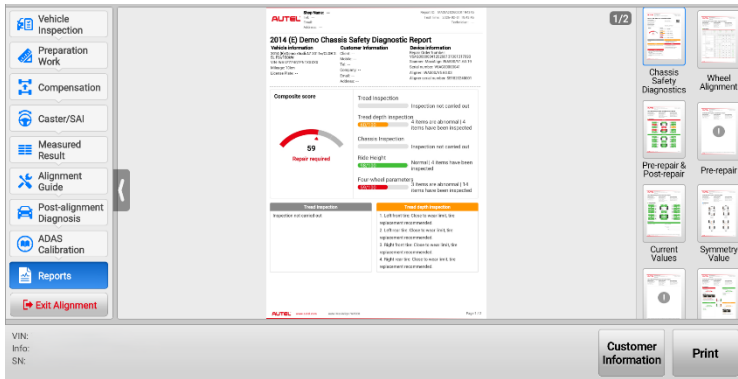

Figure 6-97 Report with No Data Generated 1

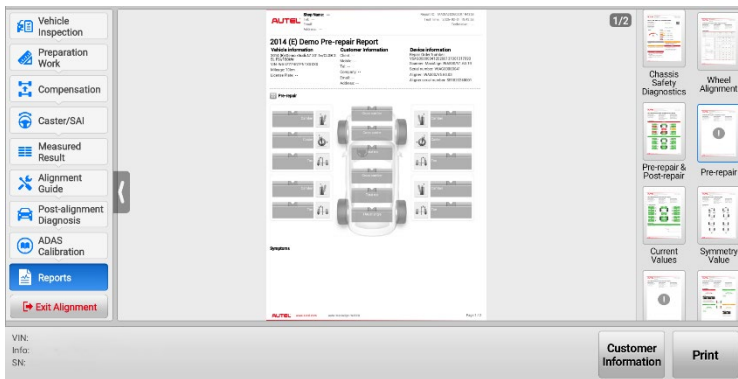



Figure 6-98 Report with No Data Generated 2

6.4.8.3 Save Report and Report Cloud Sharing

After performing a vehicle inspection and wheel alignment, you can save the reports and share them to the cloud, and then share the cloud reports via QR code, email, or SMS to customers in real time.

➤ To save reports

1. On the Wheel Alignment Reports screen, tap the  button on the top toolbar to open the drop-down list. Tap **Save current PDF file**.

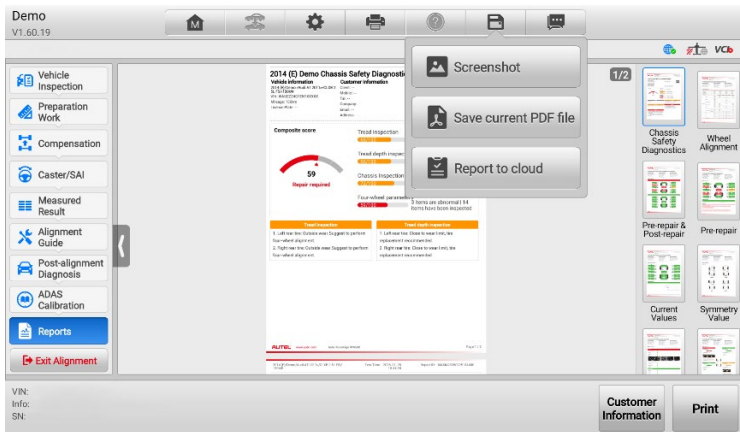

Figure 6-99 Save Report Screen 1

2. On the Save as PDF screen, input the file name and tap **Save**.



Figure 6-100 Save Report Screen 2

3. Once the tablet displays the following screen, it indicates that the reports have been saved successfully. Tap **OK** and return to the Reports screen.

Four-Wheel Parameters

Left rear toe in, Right rear toe in, and Front angle
Exceeding specified ranges, so, set them up again.
After the wheel alignment parameters are adjusted, the
Distance to 0.01mm should be recorded.
All the wheel alignment parameters are adjusted, the
Camera external calibration is required.

Figure 6-103 PDF Report Sample, Page 2

Wheel Alignment

	Left front	Right front	Left rear	Right rear		
Incl. angle	-0.000°	0.000°	0.000°	0.000°		
tire pressure	2.4bar	2.4bar	2.4bar	2.4bar		
Rolling diameter	475mm	475mm	475mm	475mm		
axle height	550mm	550mm	550mm	550mm		
		Before repair	Minimum	Standard	Maximum	Measured
Toe	Left	0.00°	-0.20°	0.10°	0.42°	0.00°
	Right	0.00°	-0.20°	0.10°	0.42°	0.00°
	Total	0.00°	-0.40°	0.20°	0.84°	0.00°
	Left	-0.00°	0.70°	0.51°	0.74°	-0.00°
	Right	0.00°	0.70°	0.51°	0.74°	0.00°
Camber	Overall	-0.00°	-0.30°	0.00°	0.30°	-0.00°
	Left	0.00°	-0.10°	0.00°	0.10°	0.00°
	Right	0.00°	-0.10°	0.00°	0.10°	0.00°
	Left	0.00°	-0.10°	0.00°	0.10°	0.00°
	Right	0.00°	-0.10°	0.00°	0.10°	0.00°
Caster	Left	0.00°	0.70°	0.60°	0.70°	0.00°
	Right	0.00°	0.70°	0.60°	0.70°	0.00°
	Overall	0.00°	0.70°	0.60°	0.70°	0.00°
	Left	1.21°	0.90°	1.00°	1.32°	1.21°
	Right	-1.12°	-1.30°	-1.50°	-0.90°	-1.12°
Front axle SAI	Overall	2.32°	1.90°	2.00°	2.32°	2.32°
	Left	1.32°	--	--	--	1.32°
	Right	-1.12°	--	--	--	-1.12°
Toe out/in across	Left	--	-2.10°	-1.80°	-1.10°	--
	Right	--	-2.10°	-1.80°	-1.10°	--
	Overall	0.00°	--	--	--	0.00°
Set back	Left over	Left over	41.58k	40.56k	40.56k	41.58k
	Right over	Right over	31.72k	30.70k	30.70k	31.72k
	Left over	Left over	31.72k	30.70k	30.70k	31.72k
	Right over	Right over	41.58k	40.56k	40.56k	41.58k
	Total	Total	-1.54°	0.70°	0.10°	0.42°
Toe	Left	-0.01°	-0.10°	0.20°	0.30°	-0.02°
	Right	1.53°	0.70°	0.10°	0.42°	1.52°
	Total	-0.01°	-0.10°	0.20°	0.30°	-0.02°
	Left	0.00°	-0.10°	0.00°	0.00°	-0.01°
	Right	0.00°	-0.22°	0.02°	0.21°	-0.01°
Near side	Total	0.00°	-0.10°	0.00°	0.00°	-0.01°
	Left	0.00°	-0.22°	0.00°	0.00°	0.00°
	Right	0.00°	-0.22°	0.00°	0.00°	0.00°
Thrust angle	Left	0.00°	0.00°	0.00°	0.00°	0.00°
	Right	0.00°	0.00°	0.00°	0.00°	0.00°

Figure 6-104 PDF Report Sample, Page 3

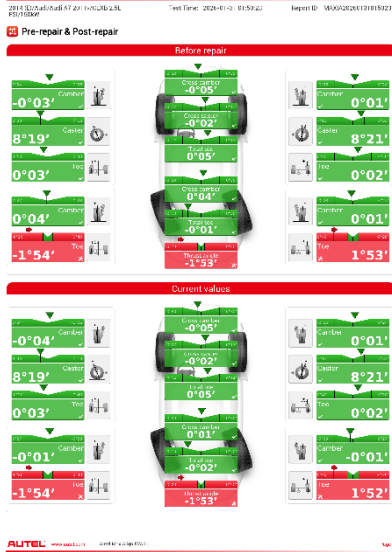



Figure 6-105 PDF Report Sample, Page 4



Figure 6-106 PDF Report Sample, Page 5

➤ **To report to the cloud**

1. On the Wheel Alignment Reports screen, tap the  button to open the drop-down list, and tap the **Report to Cloud** button.

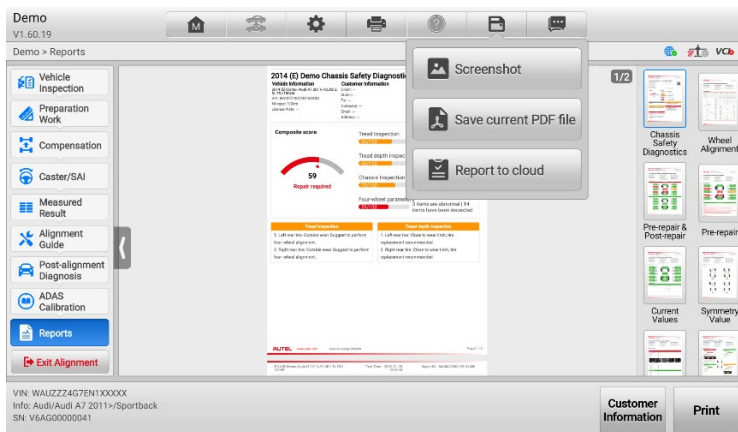

Figure 6-107 Report to Cloud Screen 1

2. Once the tablet displays the following screen, it indicates that the reports have been saved to the cloud successfully. Tap **Close** to return to the Reports screen, or tap **View Report** to view the report.

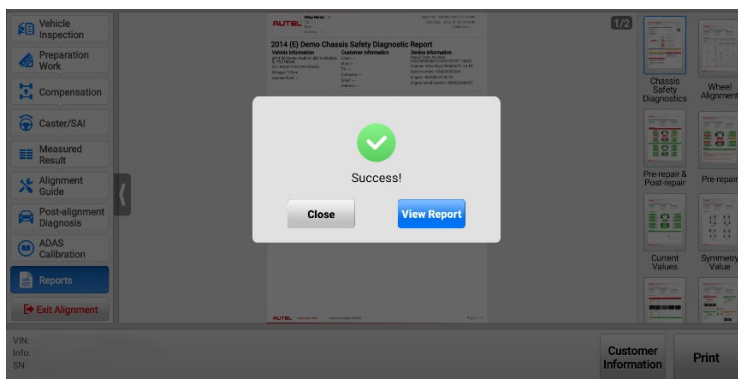

Figure 6-108 Report to Cloud Screen 2

➤ **To share reports**

1. Either tap **View Report** (refer to [Figure 6-101 Save Report Screen 3](#)) or tap the **Data Manager** application, select the **Cloud Report** icon, and select a specific report to access the Test Report screen.

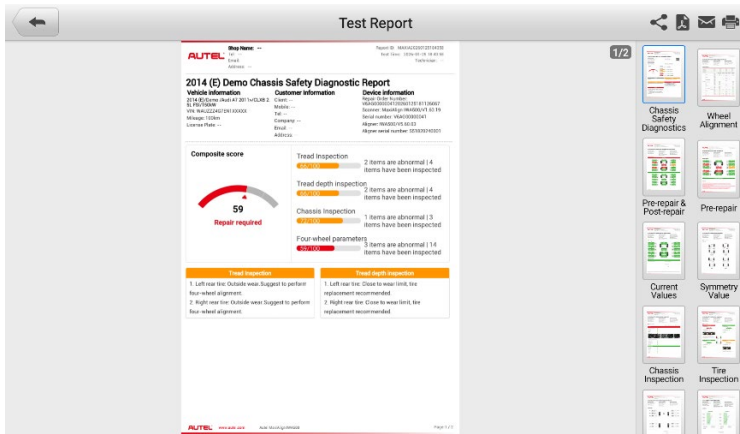





Figure 6-109 Test Report Screen

NOTE

On the *Report List* screen under **Data Manager > Cloud Report**, a report marked with  indicates that it has been successfully uploaded to the cloud and can be shared with others; while a report marked with  indicates a failed cloud upload and cannot be shared.

2. Tap the  button on the top toolbar to share the report.
- 1) Scan the QR code to view the report directly. The QR code for each report is different.

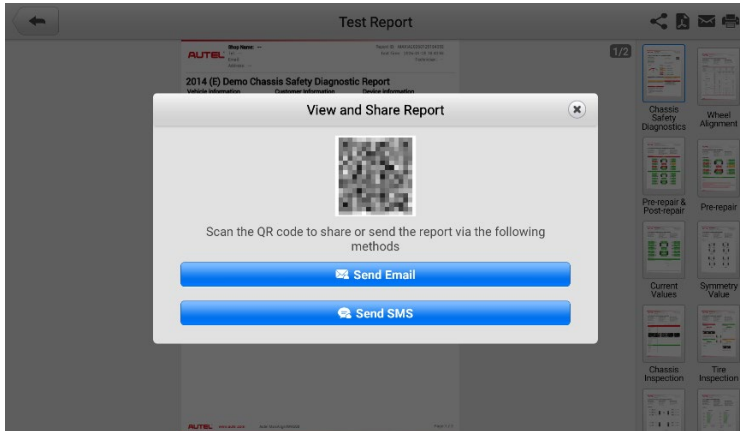

Figure 6-110 Report Cloud Sharing Method Screen

- 2) Tap **Send Email**, input the Email address, and then tap **Send** to share the report.

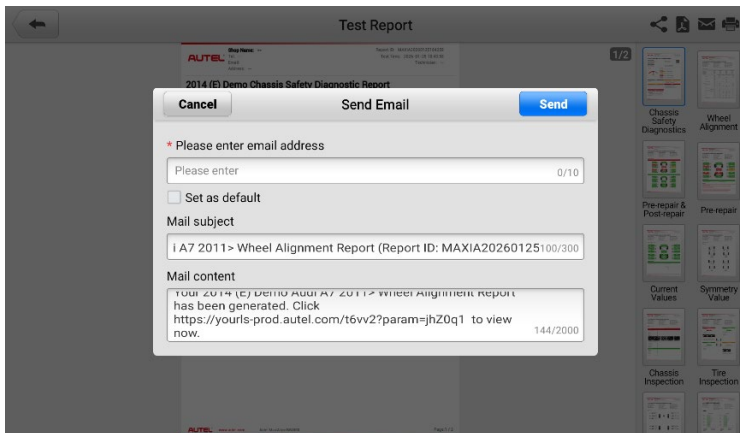

Figure 6-111 Send Email Screen

- 3) Tap **Send SMS**, input the phone number, and then tap **Send** to share the report.

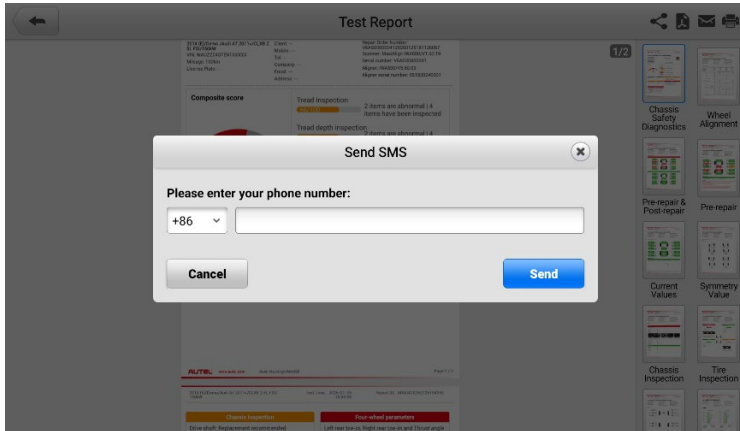
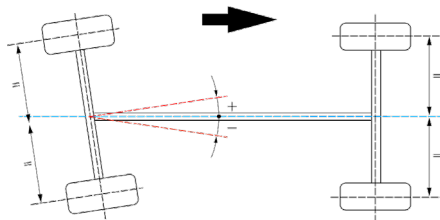

Figure 6-112 Send SMS Screen

6.5 Glossary

6.5.1 Geometry Centerline

Geometry Centerline refers to the intersection of the longitudinal center plane of the body and the horizontal plane of the front and rear axles (blue dotted line).



6.5.2 Thrust Angle

❖ Definition

The thrust angle is the angle between the longitudinal geometric center plane of the vehicle and the thrust line (the driving axis is the perpendicular line of the rear axle center). As shown in the picture below.

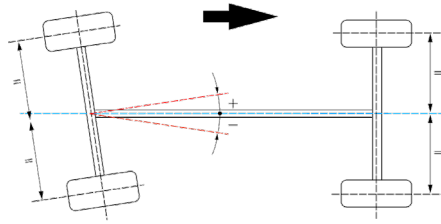

✧ Function

Ensure that the vehicle is driven straight ahead.

✧ Effects of abnormal thrust angle

- The steering wheel is tilted when the vehicle is driven straight ahead.
- The tires are abnormally worn, and the vehicle pulls to one side.

6.5.3 Toe

✧ Definition

The toe is the angle between the center plane of the wheel rotation and the longitudinal plane of the vehicle (as shown in the picture below).

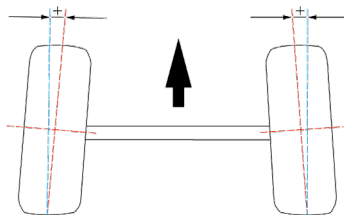

✧ Function

Eliminate or reduce the adverse effects when the front ends of the two wheels spread outward due to the camber in driving. Ensure that the wheels do not roll outwards. Prevent the wheels from sliding laterally and reduce tire wear and fuel consumption.

◇ Effects of abnormal toe

- One side of the tire is abnormally worn.
- The vehicle has excessive vibrations when driving at high speeds.
- The steering wheel is tilted when driving straight ahead.

6.5.4 Total Toe

The sum of the toe-in of the coaxial left and right wheels.

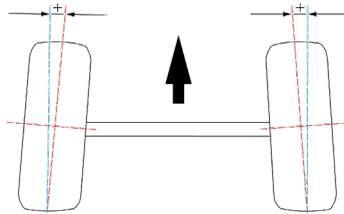

6.5.5 Camber

◇ Definition

The camber is the angle between the wheel rotation plane and the longitudinal plane perpendicular to the vehicle bearing plane. If the upper part of the wheel is tilted outward relative to the rotation plane, the camber is positive. If the upper part of the wheel is tilted inward, it is the negative camber (as shown in the picture below).

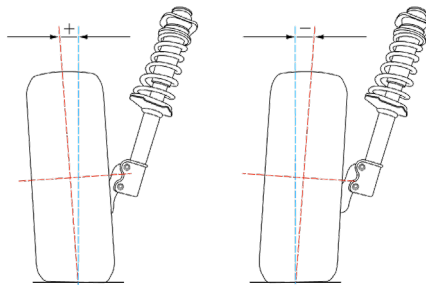

◇ Function

Improve the safety of the front wheels and make the steering lighter when driving.

✧ Effects of abnormal camber

- When the camber is too large, the outer side of the wheel is worn. The vehicle has excessive vibrations, and the steering wheel is unstable when driving at high speeds.
- When the camber is too small, the inner side of the wheel is worn. The steering is heavy, and there is not enough force to return the steering wheel automatically to the center position.
- When the left camber and the right camber are not equal, the vehicle slides laterally and deviates when driving.

6.5.6 Front Caster

✧ Definition

The kingpin is the center of rotation when the wheel is turning. The caster is the angle between the kingpin axis and the perpendicular line of the vehicle bearing plane (as shown in the picture below).

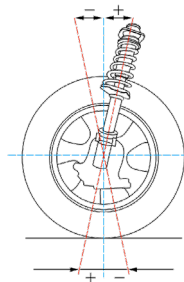

✧ Function

Create a force to return the steering wheel automatically to the center position. Ensure the vehicle stability when driving straight ahead. It also makes the steering wheel lighter and easier to return after the vehicle changes direction.

✧ Effects of abnormal caster

- When the left caster and the right caster are not equal, the left wheels are not synchronized with the right wheels when the vehicle changes direction. The vehicle will also deviate when driving.
- When the caster is too small, the steering wheel is unstable.
- When the caster is too large, the steering is heavy.

6.5.7 Steering Axis Inclination (SAI)

◇ Definition

The steering axis inclination is the angle between the kingpin axis and the vertical line in the lateral vertical plane of the vehicle (as shown in the picture below).

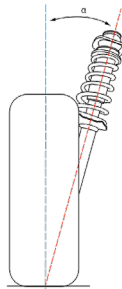

◇ Function

When the wheels deviate from the straight-ahead position due to external force, the front wheels will automatically return to the straight-ahead position.

◇ Effects of abnormal steering axis inclination

- When the steering axis inclination is too large, the required steering force becomes larger, and the steering becomes difficult.
- When the steering axis inclination is too small, the steering system cannot fully return to the center position after the vehicle makes a turn.
- When the left steering axis inclination and the right steering axis inclination are not equal, the vehicle may pull to one side.

6.5.8 Included Angle (IA)

✧ Definition

The included angle is the angle γ between the kingpin axis and the wheel axis. The value of the included angle is the sum of the steering axis inclination α and the camber β (as shown in the picture below).

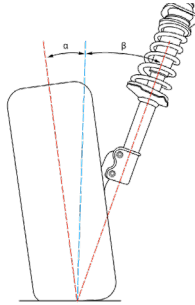

✧ Function

The included angle is used for diagnosing the suspension system misalignment and the suspension component deformation.

✧ Effects of abnormal included angle

- When the included angle is too small, the steering axis inclination is normal, and the camber is too small, the shaft journal may be bent.
- When the included angle is normal, the steering axis inclination is too small, and the camber is too large, the lower control arm may be bent.
- When the included angle is normal, the steering axis inclination is too large, and the camber is too small, the upper control arm may be bent.
- When the included angle is too large, the steering axis inclination is too small, and the camber is too large, the lower control arm and the shaft journal may be bent.

6.5.9 Toe-out on Turns

✧ Definition

The Ackerman angle is the difference between the outer wheel steering angle and the inner wheel steering angle when the vehicle makes a turn.

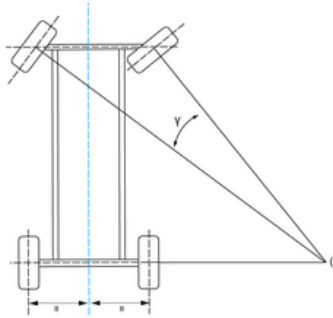

✧ Function

Ensure that the two front wheels point in the correct direction for more grip.

✧ Effects of abnormal Ackerman angle

- The tires may have a feathering condition.
- The tires may slide laterally, jump, or make abnormal noises due to insufficient grip when the vehicle makes a turn.

6.5.10 Maximum Steering Angle

✧ Definition

The maximum steering angle is the angle that the wheel rotation plane covers when the front wheels turn from the straight-ahead position to the left or right limit position.

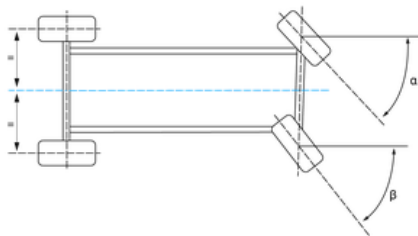

✧ Function

Control the minimum turning radius and ensure the vehicle's driving stability and maneuverability.

✧ Effects of abnormal maximum steering angle

- The vehicle may slide while driving.
- There may be noise when the vehicle makes a turn.
- The steering wheel may shake.
- The steering is heavy.
- In extreme cases, the vehicle may roll over.

6.5.11 Ride Height

The location and method of ride height vary by vehicle manufacturer. See below for details.

- Ride height of vehicle manufacturers such as Volkswagen, Audi, Porsche, etc.

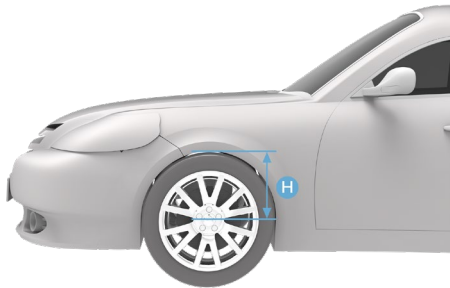

- Ride height of vehicle manufacturers such as BMW.

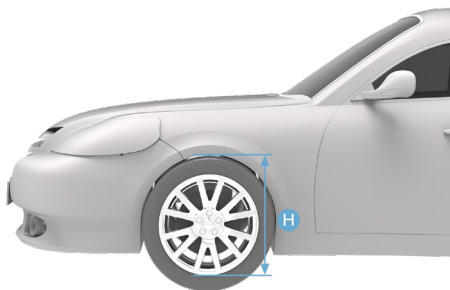

- Ride height of vehicle manufacturers such as Mercedes-Benz, Maybach, etc., determined by measuring the inclination of chassis-related components.

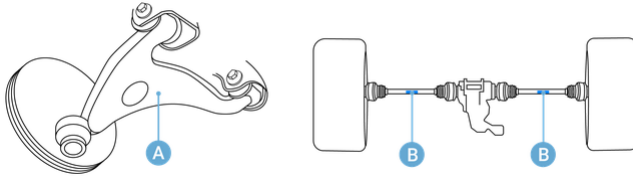

- Ride height of vehicle manufacturers such as Renault, Peugeot, more than one value that needs to be measured on one tire position.

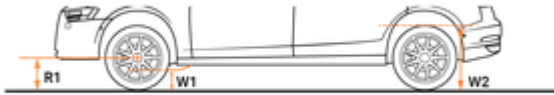

6.5.12 Setback Angle

- ◇ Definition

The setback angle is the angle between the vertical line of the wheel center connecting line and the thrust line.

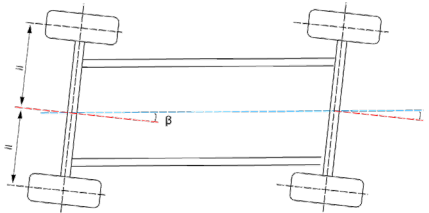

- ◇ Function

To diagnose the axle deformation.

- ◇ Effects of abnormal setback angle

- The setback angle leads to the difference between the left and right wheelbases, and the vehicle pulls to the side of the shorter wheelbase.

6.5.13 Wheel Straight Ahead

Half of the difference value of the front wheel left toe minus right toe.

6.5.14 Symmetrical Value

The geometric dimensions of the vehicle are usually symmetrical, which is used to preliminarily judge whether the vehicle has had an accident and the health status of the chassis, and assist in the four-wheel alignment.

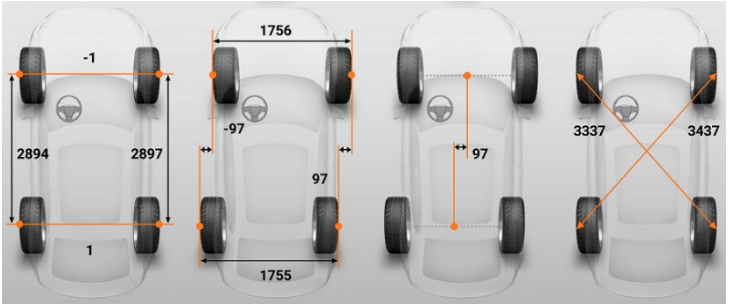

6.5.15 Rolling Diameter

The rolling radius R is equal to the distance from the center of the wheel to the ground. The rolling diameter is equivalent to two rolling radii.

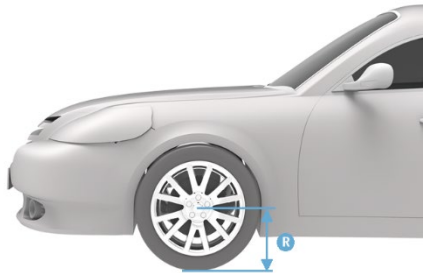

7 Hand-held Inclinometer

Connect the hand-held inclinometer to the tablet and launch the application to measure the Mercedes-Benz vehicles' ride height. This measurement serves as the data basis for adjusting the values of wheel camber, caster, and toe during wheel alignment.

➤ **To measure the ride height of Mercedes-Benz vehicle**

1. Connect the hand-held inclinometer to the tablet using the supplied USB cable.

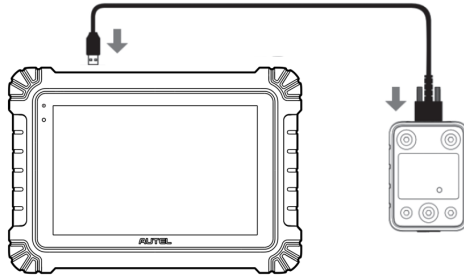

Figure 7-1 Connecting MaxiSys Tablet to Hand-held Inclinometer

2. Tap the **Hand-held Inclinometer** application button on the MaxiSys Job Menu to open the vehicle series selection screen.

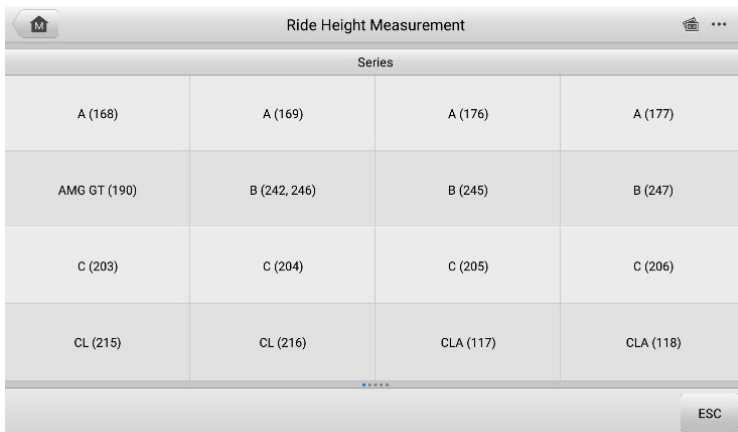

Figure 7-2 Vehicle Series Selection Screen

3. Follow the on-screen instructions to measure the ride height. The measured results will be automatically uploaded to the tablet and displayed in the corresponding input box.

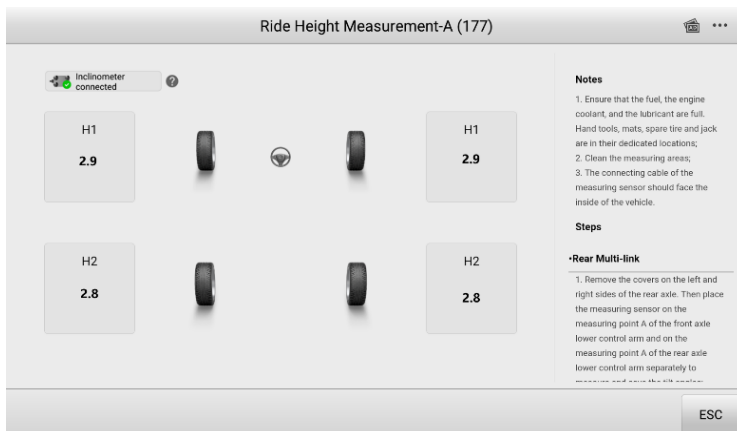

Figure 7-3 Ride Height Measurement Result Screen

NOTE

Tap the **...** button in the upper-right corner of the screen to open the drop-down menu options: Calibrate, Update, and Help. A quick reference guide on how to use the Autel hand-held inclinometer will be displayed after tapping the **Help** option.

8 Wheel Alignment Filter

The Wheel Alignment Filter application allows you to check whether a specific vehicle supports wheel alignment and SAS functions using our tools.

➤ **To perform Wheel Alignment Filter function**

1. Tap the **Wheel Alignment Filter** application from the MaxiSys Job Menu.
2. Tap the product type in the top-left corner to open the drop-down list. Select a tool. Here we select IWA500 for illustration.

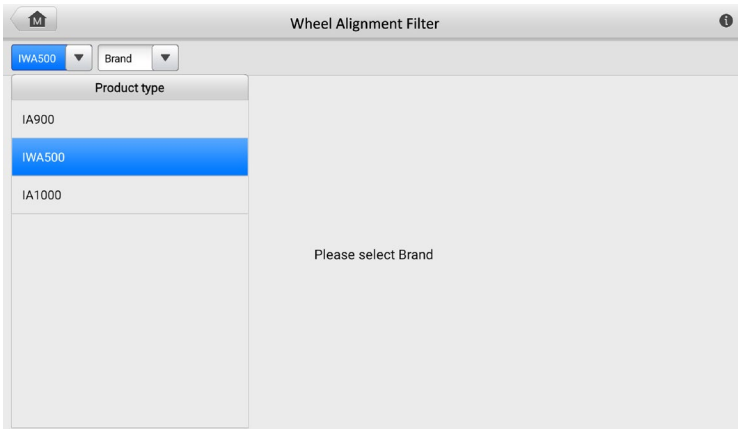

Figure 8-1 Wheel Alignment Filter Screen 1

3. Select the vehicle's brand, model, and year from the drop-down list.

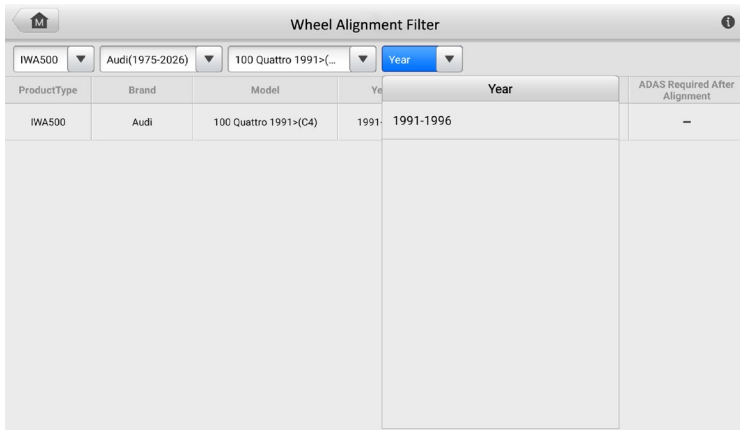

Figure 8-2 Wheel Alignment Filter Screen 2

- The screen will display whether the vehicle supports wheel alignment and SAS functions using our tools. The ● icon indicates support, while the — icon indicates no support.

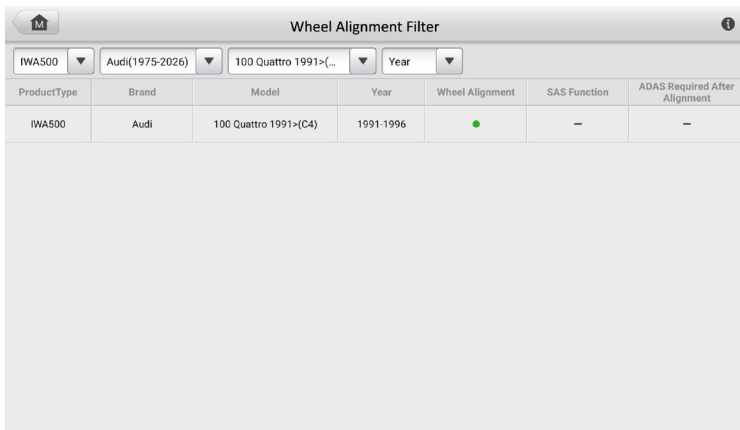

Figure 8-3 Wheel Alignment Filter Screen 3

9 MaxiViewer

The MaxiViewer application allows you to search for the functions supported by our tools and the version information. There are two ways for searching, either by searching the tool and the vehicle or by searching the functions.

➤ **To search by the vehicle**

1. Tap the **MaxiViewer** application button on the MaxiSys Job Menu. The MaxiViewer screen displays.
2. Tap the tool name in the top-left corner to drop down the tool list. Tap the one you want to search.
3. Tap the vehicle brand, model, and year you want to search.

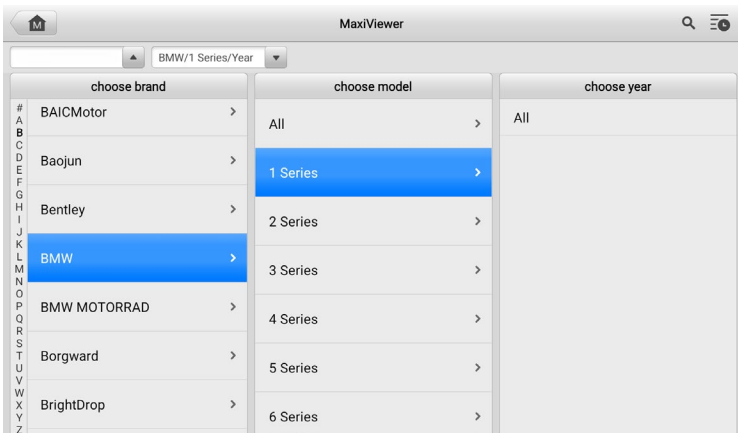
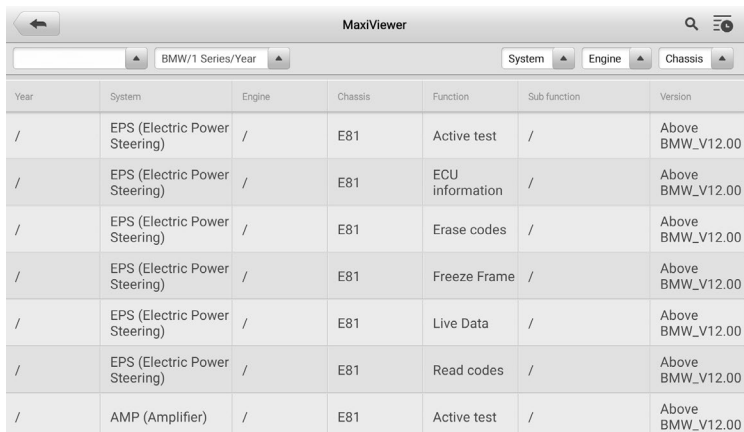

Figure 9-1 Function Viewer Screen 1

4. All the functions supported by the selected tool for the selected vehicle display as several columns.



The image shows the MaxiViewer application interface. At the top, there is a search bar with a magnifying glass icon and a list icon. Below the search bar, there are three dropdown menus: 'BMW/1 Series/Year', 'System', 'Engine', and 'Chassis'. The main area is a table with the following columns: Year, System, Engine, Chassis, Function, Sub function, and Version. The table contains seven rows of data.

Year	System	Engine	Chassis	Function	Sub function	Version
/	EPS (Electric Power Steering)	/	E81	Active test	/	Above BMW_V12.00
/	EPS (Electric Power Steering)	/	E81	ECU information	/	Above BMW_V12.00
/	EPS (Electric Power Steering)	/	E81	Erase codes	/	Above BMW_V12.00
/	EPS (Electric Power Steering)	/	E81	Freeze Frame	/	Above BMW_V12.00
/	EPS (Electric Power Steering)	/	E81	Live Data	/	Above BMW_V12.00
/	EPS (Electric Power Steering)	/	E81	Read codes	/	Above BMW_V12.00
/	AMP (Amplifier)	/	E81	Active test	/	Above BMW_V12.00

Figure 9-2 Function Viewer Screen 2

➤ **To search by the functions**

1. Tap the **MaxiViewer** application button on the MaxiSys Job Menu. The MaxiViewer screen displays.
2. Tap the tool name in the top-left corner to drop down the tool list. Tap the one you want to search.
3. Tap the search icon in the top-right corner and enter the function you want to search for in the box. The screen will display all vehicles that support this function, along with information such as the vehicles' year, system, function, sub-function, and version.

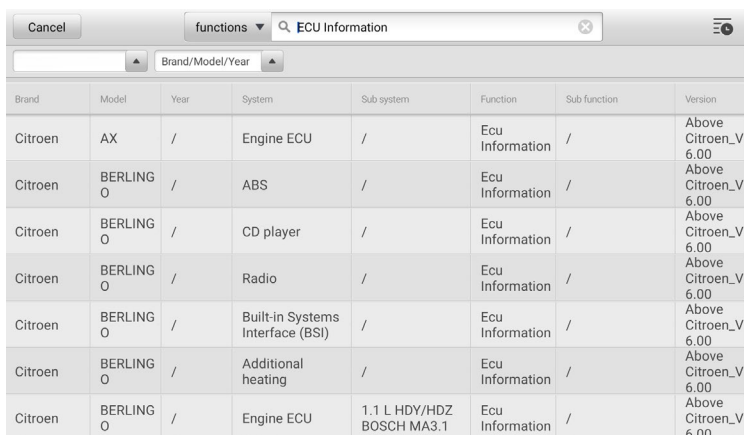

The image shows the MaxiViewer application interface with a search filter applied. At the top, there is a search bar with a magnifying glass icon and a list icon. Below the search bar, there is a dropdown menu labeled 'functions' and a search input field containing 'ECU Information'. Below the search bar, there are three dropdown menus: 'Brand/Model/Year', 'System', 'Engine', and 'Chassis'. The main area is a table with the following columns: Brand, Model, Year, System, Sub system, Function, Sub function, and Version. The table contains seven rows of data.

Brand	Model	Year	System	Sub system	Function	Sub function	Version
Citroen	AX	/	Engine ECU	/	Ecu Information	/	Above Citroen_V 6.00
Citroen	BERLINGO	/	ABS	/	Ecu Information	/	Above Citroen_V 6.00
Citroen	BERLINGO	/	CD player	/	Ecu Information	/	Above Citroen_V 6.00
Citroen	BERLINGO	/	Radio	/	Ecu Information	/	Above Citroen_V 6.00
Citroen	BERLINGO	/	Built-in Systems Interface (BSI)	/	Ecu Information	/	Above Citroen_V 6.00
Citroen	BERLINGO	/	Additional heating	/	Ecu Information	/	Above Citroen_V 6.00
Citroen	BERLINGO	/	Engine ECU	1.1 L HDY/HDZ BOSCH MA3.1	Ecu Information	/	Above Citroen_V 6.00

Figure 9-3 Function Viewer Screen 3

 **NOTE**

Fuzzy search is supported. Type in part of a function-related keyword to find all the available information.

10 Update



The Update application on the tablet downloads the latest version of the software. The updates improve the MaxiSys applications' capabilities, typically by adding new tests, new model coverage, or adding new or enhanced applications.

The tablet automatically searches for available updates for all of the MaxiSys software when it is connected to a network. Any updates that are found can be downloaded and installed on the device.

NOTE

Ensure the tablet is registered before using the Update application. See [Autel User Center](#) for a comprehensive registration guide.

➤ To update the software

1. Power up the tablet, and ensure that it is connected to a power source and has a stable network connection.
2. Tap the **Update** application button from the MaxiSys Job Menu. The Update screen displays.
3. On the Update screen, tap the **Get** button to update the specific item(s) or tap the **Update All** button to update all available items.
4. Tap **More** to view the details about all the available updates. You can also tap the **Get** or **Update All** button to update.
5. During the update, tap the  icon to suspend the updating process. Tap the  icon to resume the update, and the process will continue from the pause point.
6. When the updating process is completed, the software will be installed automatically. The new version will replace the older version.

NOTE

For the account management, proceed to the Member Center tab.

11 Data Manager

The Data Manager application allows you to store, print, and review saved files, manage workshop information and customer information records, and store test vehicle histories.

Selecting the **Data Manager** application opens the file system menu. Nine main functions are available.

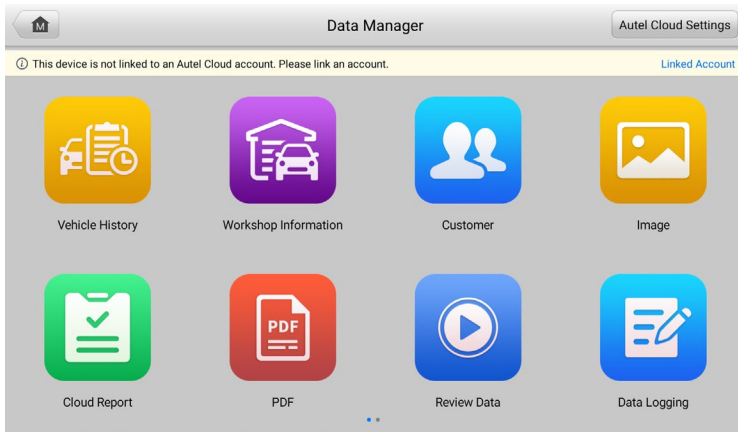

Figure 11-1 Data Manager Main Screen

In the Data Manager application, data can be backed up to Autel Cloud automatically or manually. Before backing up data, you first need to link the device to Autel Cloud.

➤ **To link the device to Autel Cloud**

1. On the Data Manager main screen, tap **Link Account** to access Autel Cloud.
2. Tap **Add your device**, enter the device serial number and device registration password, and tap **Save**. The linked device will appear on the Device List screen. (To find the device serial number and device registration password, go to **Settings > About**.)

➤ **To switch a linked account**









1. Tap **Data Manager** on the MaxiSys Job Menu.
2. On the Data Manager main screen, tap **Switch Linked Account** to access Autel Cloud. Log in to Autel Cloud with your account.

➤ **To back up data to Autel Cloud automatically**

1. On the Data Manager main screen, tap **Autel Cloud Settings**, and toggle the **Automatic Upload** buttons to **On**.
2. Data, including reports, images, PDF files, review data, and reference values, are backed up to Autel Cloud automatically.

The table below briefly describes each of the function buttons in the Data Manager application.

Table 11-1 Buttons in Data Manager

Button	Name	Description
	Vehicle History	Tap to review the diagnostics and wheel alignment history record.
	Workshop Information	Tap to edit the workshop information.
	Customer	Tap to create new customer information.
	Image	Tap to review the screenshots.
	Cloud Report	Tap to review the saved reports and share cloud reports.
	PDF	Tap to review the reports stored as PDF files.
	Review Data	Tap to review the recorded data.
	Data Logging	Tap to review the communication data and ECU information about the vehicle. The saved data can be reported and sent to the technical center via the Internet.
	Uninstall Apps	Tap to uninstall applications.

11.1 Vehicle History

This function stores historical records of wheel alignment and diagnostics. Test information is summarized and displayed in an easy-to-read table listing. The Vehicle History also provides direct access to previously tested vehicles and allows you to directly restart a wheel alignment or diagnostic session without needing to perform auto or manual vehicle selection.

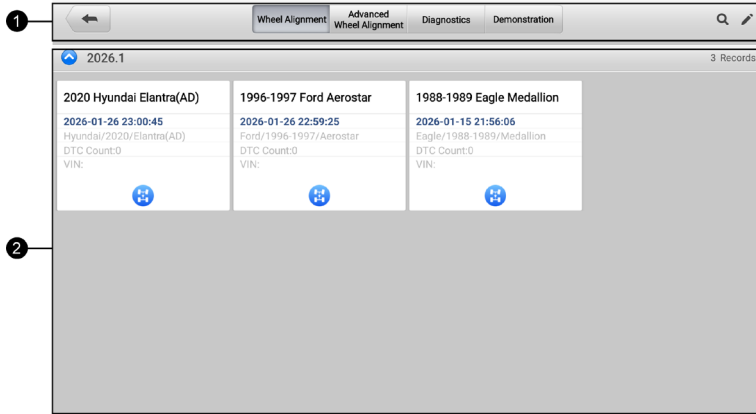

Figure 11-2 Vehicle History Screen

1. Top Toolbar Buttons — navigation and application controls.
 2. Main Section — displays all the vehicle history records.
- **To activate a test session for the recorded vehicle**
1. Tap **Data Manager** on the MaxiSys Job Menu.
 2. Select **Vehicle History** to open the screen. Tap the relevant application tab to select the test record. Take selecting the **Diagnostics** tab as an example.
 3. Tap the **Diagnostics** icon at the bottom of the thumbnail of a vehicle record item.
 4. The Diagnostics screen of the vehicle displays, and a new diagnostic session is activated.
 5. Select a vehicle thumbnail to open a record. A Historical Test record sheet displays. Review the recorded information of the test vehicle, and tap the **Diagnostics** button in the upper-right corner.

NOTE

The MaxiSys tablet must establish a stable connection to the VCI device to restart test sessions of Advanced Wheel Alignment and Diagnostics on the previously tested vehicles.

11.1.1 Historical Test Record

The Historical Test Record is a detailed vehicle data form that contains general vehicle information, service record, and customer information for all test types. For Diagnostics sessions, it also includes diagnostic trouble codes retrieved from previous test sessions. Technician notes will be displayed if present.

Vehicle Information			
Year	2016	License plate	
Make	Land Rover	VIN	
Model	New Range Rover (L405)	Odometer	
Sub model		Color	
Engine	Diesel Particulate Filter (cDPF)	Status	Not started

Figure 11-3 Historical Test Record Sheet

➤ To edit the historical test record

1. Tap **Data Manager** on the MaxiSys Job Menu.
2. Select **Vehicle History**.
3. Select a specific vehicle history record thumbnail from the main section. The Historical Test record will display.
4. Tap **Edit** (a pen icon) to start editing.
5. Tap each item to input information or attach files or images.

🔗 NOTE

The vehicle VIN, license number, and customer account information are correlated by default. Vehicle records will automatically be correlated using this vehicle and customer identification.

6. Tap **Add to Customer** to correlate the historical test record sheet to an existing customer account, or to add a new associated account to be correlated with the test vehicle record. See [Customer](#) for more information.
7. Tap **Done** to save the updated record, or tap **Cancel** to exit without saving.

11.2 Workshop Information

The Workshop Information form allows you to edit and save detailed workshop information such as the shop name, address, and phone number. This information will display as the header of printed vehicle reports and other associated test files.

The screenshot shows a mobile application interface for editing workshop information. At the top, there is a back arrow and the title 'Workshop information'. Below this, the form is organized into two main sections: 'Basic information' and 'More information'. The 'Basic information' section contains two columns. The left column has a 'Set shop logo' field with a '+' icon, followed by 'Shop name', 'State', 'City', 'Zip code', and 'Address'. The right column has a 'Logo' field with a '+' icon, followed by 'Tel', 'Fax', and 'E-mail'. The 'More information' section contains three fields: 'Manager name', 'Manager title', and 'Website'.

Figure 11-4 Workshop Information Sheet

- **To edit the Workshop Information sheet**
 1. Tap **Data Manager** on the MaxiSys Job Menu.
 2. Select **Workshop Information**.
 3. Tap on each field to input the relevant information.
 4. The information will be saved automatically.

11.3 Customer

The Customer function allows you to create and edit customer accounts. It helps you to save and organize all customer information accounts that are correlated with the associated test vehicle history records.

- **To create a customer account**
 1. Tap **Data Manager** on the MaxiSys Job Menu.
 2. Select **Customer**.
 3. Tap the **Add a Customer** button. An empty information form displays; tap each field to input the relevant information.

 **NOTE**

The items that must be filled are indicated as required fields.

4. Some customers may have more than one vehicle for service; you can always add new vehicle information to the account. Tap **Add New Vehicle Information**, and then fill in the vehicle information. Tap the  button to cancel.
 5. Tap **Complete** to save the account, or tap **Cancel** to exit without saving.
- **To edit a customer account**
1. Tap **Data Manager** on the MaxiSys Job Menu.
 2. Select **Customer**.
 3. Select a customer account by tapping its name card. A Customer Information record displays.
 4. Tap **Edit** on the top toolbar to start editing.
 5. Tap on the input field to edit or amend information, and input updated information.
 6. Tap **Complete** to save the updated information, or tap **Cancel** to exit without saving.
- **To delete a customer account**
1. Tap **Data Manager** on the MaxiSys Job Menu.
 2. Select **Customer**.
 3. Tap the **Delete** icon on the right of a customer account. A message is displayed.
 4. Tap **OK** to confirm the command, and the account is deleted, or tap **Cancel** to cancel the request.

11.4 Image







The Image section is a PNG database containing all captured screenshots.



Figure 11-5 Image Database Screen

1. **Toolbar Buttons** — used to edit, print, or delete the image files. See the following table for detailed information.
2. **Main Section** — displays the stored images.

Table 11-2 Toolbar Buttons in PNG Database

Button	Name	Description
	Back	Returns to the previous screen.
	Search	Tap to search the image by entering its stored time.
	Edit	Tap to display the editing toolbar to select, delete, print, or email the image(s).
	Cancel	Tap to close the editing toolbar or cancel file search.
	Print	Tap to print the selected image.
	Delete	Tap to delete the selected image.

Button	Name	Description
	Email	Tap to send the selected image to an email.

➤ **To edit/delete image(s)**

1. Tap **Data Manager** on the MaxiSys Job Menu.
2. Select **Image** to access the PNG database.
3. Tap **Edit** in the top-right corner of the window. The editing screen displays.
4. Select the image(s) you want to edit by tapping the check box in the bottom-right corner of each image.
5. Tap the **Delete** icon to delete the selected image(s) or delete all images. Tap the **Print** icon to print the selected image(s). Tap the **Email** icon to send the selected image(s) to an email.

➤ **To upload images to Autel Cloud**

1. Tap the **Data Manager** application button on the MaxiSys Job Menu.
2. Select **Image** to access the PNG database.
3. Tap the  icon to upload the image to Autel Cloud.

11.5 Cloud Report

This section displays the saved reports, which can be transferred to the Autel cloud platform once a stable network connection is established. These reports can then be viewed or shared with others.

11.6 PDF Files

The PDF files designated for local viewing are displayed in this section. After entering the PDF database, select a PDF file to view the stored information.

This section uses the standard Adobe Reader application for file viewing and editing. Please refer to the associated Adobe Reader manual for more detailed instructions.

11.7 Review Data

The Review Data section allows you to play back the recorded data frames of live data streams.

On the Review Data main screen, select a record file to play back.

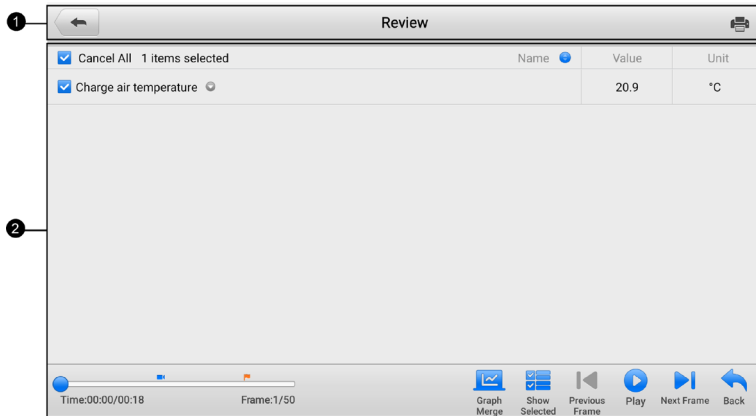

Figure 11-6 Data Playback Screen

1. Main Section — displays the recorded data frames.
2. Navigation Toolbar — allows you to manipulate data playback.

Use the Navigation Toolbar buttons to play back the record data from frame to frame.

11.8 Data Logging

The Data Logging section allows you to launch the Support platform directly to view all records of all feedback or no-feedback data loggings on the diagnostics system. For more details, see [Data Logging](#).

11.9 Uninstall Apps

This section allows you to manage the software applications installed on the MaxiSys diagnostics system. Selecting this section opens a management screen, on which you can check all available vehicle diagnostic applications.

Select the vehicle software you want to delete by tapping on the vehicle manufacturer icon. The selected item will display a blue mark in the upper-right corner. Tap the **Delete** button on the top toolbar to delete the software from the system database.

12 VCI Manager

This application pairs the tablet with the MaxiVCI V200, checks the communication status, and updates the VCI's firmware.

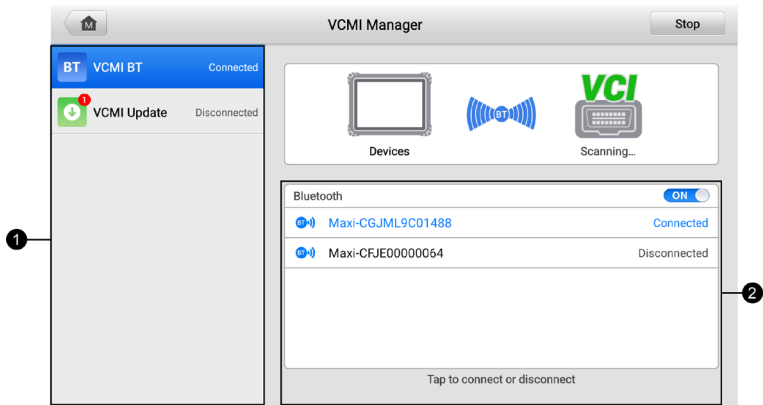

Figure 12-1 VCI Manager Screen

1. **Connection Mode:** Two connection modes are available. The connection status is displayed next to each mode.
 - VCI Bluetooth Pairing — when the VCI is paired with a device via Bluetooth, the connection status displays as “Connected.” Otherwise, it displays as “Disconnected.”
 - VCI Update — connects the VCI to the tablet and updates the VCI through the tablet.
2. **Settings:** This section allows you to manage wireless pairing or set up a network connection. Toggle the **ON/OFF** button to **ON**. The available devices for pairing will display. Tap the needed one to start pairing.

12.1 VCI Bluetooth Pairing

Bluetooth Pairing is the basic method for wireless connection. The VCI device needs to be connected to either a vehicle or an available power source so that it is powered up during the synchronization procedure. Make sure the tablet has a charged battery or is connected to an AC/DC power supply.

➤ **To pair the VCI device with the tablet**

1. Power on the tablet.
2. Insert the MaxiVCI V200 into the vehicle's DLC.
3. Tap **VCI Manager** on the MaxiSys Job Menu of the tablet.
4. Select **VCI BT** from the connection mode list.
5. Swipe the Bluetooth toggle button to **ON**. Tap **Scan** in the top-right corner. The device will start to search for available pairing units.
6. Depending on the VCI type used, the device name may display as "Maxi-" followed by a serial number. Select the appropriate device for pairing.
7. When paired successfully, the connection status displays as "Connected."
8. Wait a few seconds, and the VCI Shortcut on the navigation bar at the bottom of the screen will display a green BT icon, indicating the tablet is connected to the VCI device.
9. Tap the connected device again to disconnect it.
10. Tap **Back** on the top-left to return to the MaxiSys Job Menu.

🔍 **NOTE**

A VCI device can be paired with only one tablet at a time, and once it has been paired, the device will not be discoverable by any other unit.

12.2 VCI Update

VCI Update provides the latest update for the connected VCI device. Before updating the VCI, make sure the tablet has a stable network connection, and do not leave the VCI Update page during the upgrade.

➤ **To update the VCI**

1. Power on the tablet.
2. Connect the VCI device to the tablet via Bluetooth or USB cable.
3. Tap **VCI Manager** on the MaxiSys Job Menu of the tablet.
4. Select **VCI Update** from the connection mode list.
5. If the installed version is the latest one, the screen will prompt that the software is up to date; otherwise, the current version and the latest version will display on the screen. Tap **Update Now** to update the VCI firmware if available.

13 Support

This application launches the Support platform, which synchronizes Autel's online service base station with the MaxiSys tablet. Connected to Autel's service channel and online communities, the Support application provides the fastest way to solve problems, allowing you to send help requests to obtain direct service and support.

13.1 Support Screen Layout

The Support application interface is navigated by the Home button on the top toolbar. The main section of the Support screen is divided into two sections. The narrow column on the left is the main menu; select a subject from the main menu to display the corresponding function screen on the right.

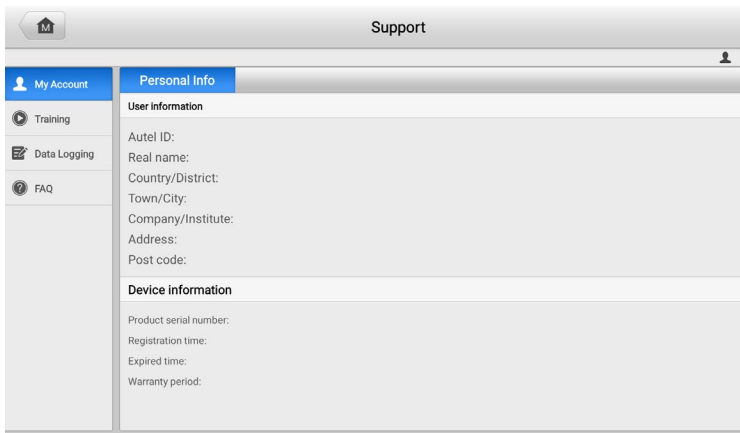

Figure 13-1 Support Application Screen

13.2 My Account

The My Account screen displays the comprehensive information about the user and the product, which is synchronized with the online registered account.

The User Information and Device Information are both included under the Personal Information section.

- User Information — displays detailed information about your registered online Autel account, such as your Autel ID, name, address, and other contact information.
- Device Information — displays the registered product information, including the product serial number, registration time, expiration time, and warranty period.

13.3 Training

The Training section provides quick links to Autel's online video accounts. Select a video channel by language to view all available Autel online tutorial videos on such topics as product usage techniques and vehicle diagnostics practices.

13.4 Data Logging

The Data Logging section keeps records of all **Feedback** (submitted), **No feedback** (not submitted but saved), and **History** (up to the latest 20 test records) data loggings on the diagnostics system. Support personnel will receive and process the submitted reports through the Support platform. The solution will be sent back as soon as possible. You may continue to correspond with the Support platform until the issue is resolved.

➤ To make a reply in a Data Logging session

1. Tap on the **Feedback** tag to view the list of submitted data loggings.
2. Select a specific item to view the latest update of the processing progress.
3. Tap the input field at the bottom of the screen, enter your reply, and tap the **Audio** button to record a voice message or tap the **Camera** button to take a screenshot.
4. Tap **Send** to deliver your message to Autel Support.

13.5 FAQ

The FAQ section provides comprehensive references for all questions frequently asked and answered about the use of Autel's online member account, shopping, and payment procedures.

- Account — displays questions and answers about the use of Autel's online user account.
- Shopping — displays questions and answers about online product purchase methods or procedures.
- Payment — displays questions and answers about online product payment methods or procedures.

14 Remote Desktop

The Remote Desktop application launches the TeamViewer Quick Support program, which is a simple, fast, and secure remote-control interface. You can use the application to receive ad-hoc remote support from Autel's support center, colleagues, or friends, by allowing them to control your MaxiSys tablet on their PC via the TeamViewer software.

14.1 Operations

If you think of a TeamViewer connection as a phone call, the TeamViewer ID would be the phone number under which all TeamViewer Clients can be reached separately. Computers and mobile devices that run TeamViewer are identified by a globally unique ID. The first time the Remote Desktop application is started, this ID is generated automatically based on the tablet's hardware characteristics and will not change.

Make sure the tablet is connected to the Internet before launching the Remote Desktop application, so that it can receive remote support from the third party.

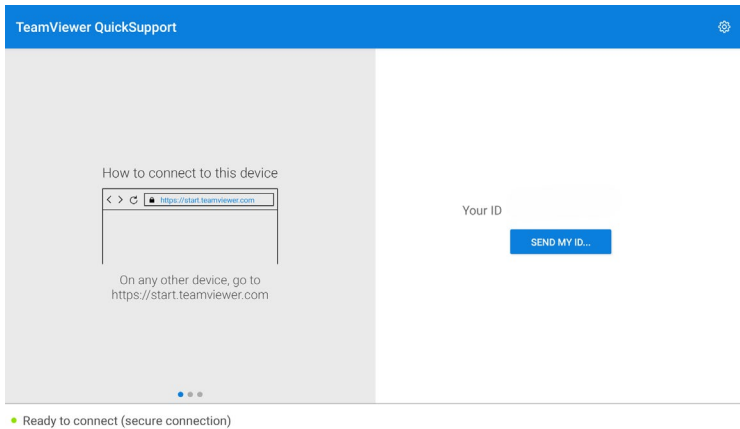

Figure 14-1 Remote Desktop Screen

- **To receive remote support from a partner**
 1. Power on the tablet.
 2. Tap the **Remote Desktop** application on the MaxiSys Job Menu. The TeamViewer interface displays, and the device ID is generated and shown.

3. Your partner must install the Remote Control software on his/her computer by downloading the TeamViewer full version program online (<http://www.teamviewer.com>), and then launch the software.
4. Provide your ID to the partner, and wait for him/her to send you a remote-control request.
5. A message will appear asking for your confirmation to allow remote control on your device.
6. Tap **Allow** to accept, or tap **Deny** to reject.

Refer to the associated TeamViewer documents for additional information.

15 Quick Link

The Quick Link application provides you with convenient access to Autel's official website and many other well-known sites in the automotive service industry to provide technical help, knowledge bases, forums, and training and expertise consultations.

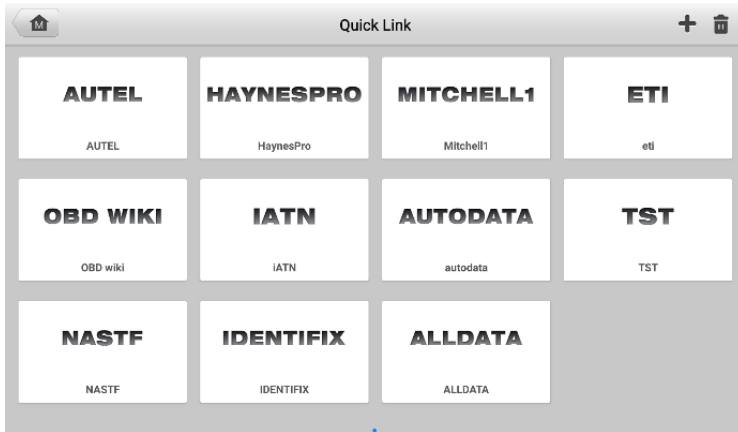

Figure 15-1 Quick Link Screen

➤ **To open a quick link**

1. Tap **Quick Link** on the MaxiSys Job Menu. The Quick Link application screen displays.
2. Select a website thumbnail from the main section. The Chrome browser is launched, and the selected website is opened.

➤ **To manage the quick links**

1. Tap **Quick Link** on the MaxiSys Job Menu. The Quick Link application screen displays.
2. Tap the **+** icon in the upper-right corner to add websites. Tap the **🗑️** icon to delete websites.

16 User Feedback

The User Feedback application allows you to submit questions related to this product.

➤ **To send user feedback**

1. Tap **User Feedback** on the MaxiSys Job Menu. The device information is automatically synchronized.

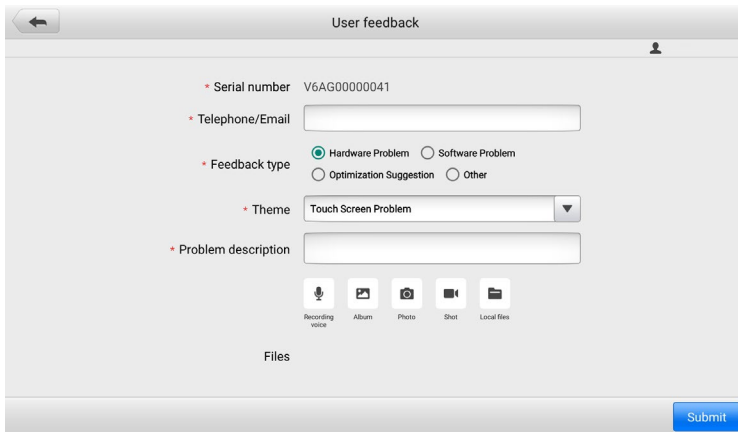

Figure 16-1 User Feedback Screen

2. Set **Telephone/Email**, **Feedback type**, **Theme**, and **Problem description**. You can also attach voice recordings, photos, screenshots, images, or PDF files. To resolve your issue efficiently, we recommend you provide as much detail as possible.
3. Tap **Submit** to send the completed information to Autel's online service center. The submitted feedback will be carefully read and addressed by our service personnel.

17 Autel User Center

The Autel User Center application allows you to register your tool to download the latest released software, thereby enhancing the functionality of the MaxiSys application by adding new vehicle models or enhanced applications to the database.

There are two ways for product registration:

A. Via the MaxiSys tablet

➤ To log in with your account and register your tool

1. Tap **Autel User Center** from the MaxiSys Job Menu. The following screen displays.

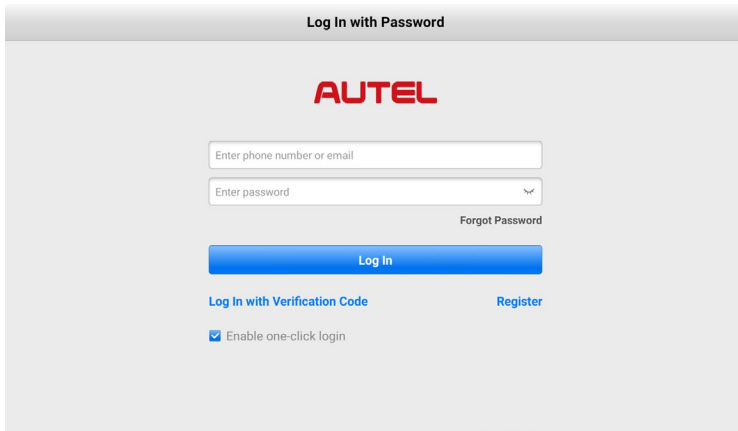

Figure 17-1 Autel User Center Screen

2. If you already have an Autel ID, you can log in with your Autel ID and password, or tap **Log In with Verification Code** to log in with your phone number and verification code. If you don't have an Autel ID yet, tap **Register** to create an Autel ID.
3. Once your account is successfully registered, you will enter the main menu of the Autel User Center.
4. Select **Device Management** on the main menu.

5. Tap the **Link Device** button in the upper-right corner of the Device Management screen. The serial number and password of the device will automatically appear on the Link Device screen.
6. Tap the **Link** button to complete the product registration.

B. Via the Autel website

➤ **To register the Autel tool**

1. Visit the website: pro.autel.com.
2. If you have an Autel account, sign in with your account ID and password and skip to step 7.
3. If you are a new member to Autel, click the **Register** button to create your Autel ID.
4. Enter the required personal information in the input fields.
5. Enter your email address and click **Request**. You will receive an email from Autel with your verification code. Open the email and copy the code into the proper input box.
6. Set a password for your account and enter it again to confirm. Read the **Autel User Service Agreement** and **Autel Privacy Policy** and check the box to accept the terms. After all the information is entered, click **Register**. A Product Registration screen will appear.
7. Your product serial number and password are required to complete your registration. To find your serial number and password on the tool: go to **Settings > About**.
8. Enter your tool's serial number and password on the Product Registration screen. Enter the CAPTCHA code and click **Submit** to finish registering.

18 Maintenance and Service

To ensure optimal performance of the tablet and combined VCI unit, strictly follow the product maintenance instructions covered in this section.

18.1 Maintenance Instructions

The following includes how to maintain your devices, together with precautions to take.

- Use a soft cloth and alcohol or a mild window cleaner to clean the touchscreen of the tablet.
- Do not use any abrasive cleansers, detergents, or automotive chemicals on the tablet.
- Keep the devices in dry conditions and within the specified operating temperature range.
- Dry your hands before using the tablet. The touchscreen of the tablet may not work if it is moist or if you tap it with wet hands.
- Do not store the devices in humid, dusty, or dirty areas.
- Check the housing, wiring, and connectors for dirt and damage before and after each use.
- Do not attempt to disassemble your tablet or the VCI unit.
- Do not drop or subject the devices to severe impact.
- Use only authorized battery chargers and accessories. Any malfunction or damage caused by the use of unauthorized battery chargers or accessories will void the limited product warranty.
- Ensure that the battery charger does not come into contact with conductive objects.
- Do not use the tablet near microwave ovens, cordless phones, or some medical or scientific instruments to prevent signal interference.

18.2 Troubleshooting Checklist

A. When the tablet does not work properly:

- Make sure the tablet has been registered online.
- Make sure the system software and diagnostic application software are properly updated.
- Make sure the tablet is connected to the Internet.
- Check all cables, connections, and indicators to see if the signal is being received.

B. When battery life is shorter than usual:

- This may happen when you are in an area with low signal strength. Turn off your device if it is not in use.

C. When you cannot turn on the tablet:

- Make sure the tablet is connected to a power source or the battery is charged.

D. When you are unable to charge the tablet:

- Your charger may be out of order. Contact your nearest dealer.
- You may be attempting to use the device in an overly hot/cold environment. Charge the device in a cooler or warmer area.
- Your device may not have been connected to the charger properly. Check the connector.

NOTE

If the problems persist, please contact Autel's technical support personnel or your local sales agent.

18.3 About Battery Usage

Your tablet is powered by a built-in lithium-ion polymer battery, which enables you to recharge your battery when there is electricity available.

DANGER

The built-in Lithium-ion Polymer battery is factory replaceable only; incorrect replacement or tampering with the battery pack may cause an explosion.

- Do not use a damaged battery charger.
- Do not disassemble, open, crush, bend, deform, puncture, or shred the battery.
- Do not modify, remanufacture, or attempt to insert foreign objects into the battery, or expose the battery to fire, explosion, or other hazards.
- Only use the specified charger and USB cables. Use of non-Autel-authorized chargers or USB cables may lead to device malfunction or failure.
- Use of an unqualified battery or charger may present a risk of fire, explosion, leakage, or other hazards.
- Avoid dropping the tablet. If the tablet is dropped, especially on a hard surface, and you suspect damage, take the tablet to a service center for inspection.
- Try to keep closer to your wireless router to reduce battery usage.
- The time needed to recharge the battery varies depending on the remaining battery capacity.
- Battery life inevitably shortens over time.
- Unplug the charger once the tablet is fully charged since overcharging may shorten battery life.
- Keep the battery in temperate environments. Do not place it inside a car when it is too hot or too cold, which may reduce the capacity and life of the battery.

18.4 Service Procedures

This section provides information on technical support, repair service, and application for replacement or optional parts.

18.4.1 Technical Support

If you have any questions or problems with the operation of the product, please contact us.

Autel China Headquarters

- **Phone:** +86 (0755) 8614-7779 (Monday-Friday, 9AM-6PM Beijing Time)
- **Email:** support@autel.com
- **Address:** Floor 2, Caihong Keji Building, 36 Hi-tech North Six Road, Songpingshan Community, Xili Sub-district, Nanshan District, Shenzhen City, China

- **Web:** www.autel.com

Autel North America

- **Phone:** 1-855-288-3587 (Monday-Friday, 9AM-6PM Eastern Time)
- **Email:** ussupport@autel.com
- **Address:** 36 Harbor Park Drive, Port Washington, New York, USA 11050
- **Web:** www.autel.com/us

Autel Europe

- **Phone:** +49(0)89 540299608 (Monday-Friday, 9AM-6PM Berlin Time)
- **Email:** support.eu@autel.com
- **Address:** Landsberger Str. 408, 81241 München, Germany
- **Web:** www.autel.eu

Autel APAC

Japan:

- **Phone:** +81-045-548-6282
- **Email:** support.jp@autel.com
- **Address:** 6th Floor, Ari-nadoribiru 3-7-7, Shinyokohama, Kohoku-ku, Yokohama-shi, Kanagawa-ken, 222-0033 Japan
- **Web:** www.autel.com/jp

Australia:

- **Email:** ausupport@autel.com
- **Address:** Unit 5, 25 Veronica Street, Capalaba

Autel IMEA

- **Phone:** +971 585 002709 (in UAE)
- **Email:** imea-support@autel.com
- **Address:** 906-17, Preatoni Tower (Cluster L), Jumeirah Lakes Tower, DMCC, Dubai, UAE
- **Web:** www.autel.com

Autel Latin America

Mexico:

- **Phone:** +52 33 1001 7880 (Spanish in Mexico)
- **Email:** latsupport@autel.com
- **Address:** Avenida Americas 1905, 6B, Colonia Aldrete, Guadalajara, Jalisco, Mexico

Brazil:

- **Email:** brsupport@autel.com
- **Address:** Avenida José de Souza Campos n° 900, sala 32 Nova Campinas Campinas – SP, Brazil
- **Web:** www.autel.com/br

18.4.2 Repair Service

If it becomes necessary to return your device for repair, please download the repair service form from www.autel.com and fill in the form. The following information must be included:

- Contact name
- Return address
- Telephone number
- Product name
- Complete description of the problem
- Proof-of-purchase for warranty repairs
- Preferred method of payment for non-warranty repairs

 **NOTE**

For non-warranty repairs, payment can be made with Visa, Master Card, or with approved credit terms.

Send the device to your local agent or to the address below:

Floor 2, Caihong Keji Building, 36 Hi-tech North Six Road, Songpingshan Community, Xili Sub-district, Nanshan District, Shenzhen City, China

18.4.3 Other Services

You can purchase the optional accessories directly from Autel's authorized tool suppliers, and/or your local distributor or agent.

Your purchase order should include the following information:

- Contact information
- Product or part name
- Item description
- Purchase quantity

19 Compliance Information

FCC Compliance

FCC ID: WQ8-DV2221

This equipment has been tested and found to comply with the limits for a Class B digital device, pursuant to Part 15 of the FCC Rules. These limits are designed to provide reasonable protection against harmful interference in a residential installation. This equipment generates uses and can radiate radio frequency energy and, if not installed and used in accordance with the instructions, may cause harmful interference to radio communications. However, there is no guarantee that interference will not occur in a particular installation. If this equipment does cause harmful interference to radio or television reception, which can be determined by turning the equipment off and on, the user is encouraged to try to correct the interference by one or more of the following measures:

- Reorient or relocate the receiving antenna.
- Increase the separation between the equipment and receiver.
- Consult the dealer or an experienced radio/TV technician for help.

This device complies with part 15 of the FCC Rules. Operation is subject to the following two conditions:

- (1) This device may not cause harmful interference, and
- (2) This device must accept any interference received, including interference that may cause undesired operation.

Changes or modifications not expressly approved by the party responsible for compliance could void the user's authority to operate the equipment.

IC Warning

IC: 10826A-DV2221

This device complies with Industry Canada's licence-exempt RSS standard(s). Operation is subject to the following two conditions:

- (1) This device may not cause interference, and
- (2) This device must accept any interference, including interference that may cause undesired operation of the device.

Le présent appareil est conforme aux CNR d'Industrie Canada applicables aux appareils radio exempts de licence. L'exploitation est autorisée aux deux conditions suivantes:

(1) l'appareil nedoit pas produire de brouillage, et

(2) l'utilisateur de l'appareil doit accepter tout brouillage radioélectrique subi, même si le brouillage est susceptible d'en compromettre le fonctionnement.

SAR

The radiated output power of this device is below the FCC radio frequency exposure limits. Nevertheless, the device should be used in such a manner that the potential for human contact is minimized during normal operation.

The exposure standard for wireless devices employs a unit of measurement known as the Specific Absorption Rate, or SAR. The SAR limit set by the FCC is 1.6 W/Kg. Tests for SAR are conducted using standard operating positions accepted by the FCC with the device transmitting at its highest certified power level in all tested frequency bands. Although the SAR is determined at the highest certified power level, the actual SAR level of the device while operating can be well below the maximum value. This is because the device is designed to operate at multiple power levels so as to use only the power required to reach the network. To avoid the possibility of exceeding the FCC radio frequency exposure limits, human proximity to antenna should be minimized.

RoHS COMPLIANCE

This device is declared to be in compliance with the European RoHS Directive 2011/65/EU.

CE COMPLIANCE

This product is declared to conform to the essential requirements of the following directives and carries the CE mark accordingly:

Radio Equipment Directive 2014/53/EU

20 Warranty

12-Month Limited Warranty

Autel Intelligent Technology Corp., Ltd. (the Company) warrants to the original retail purchaser of this MaxiSys tablet that should this product or any part thereof during normal usage and under normal conditions be proven defective in material or workmanship that results in product failure within twelve months period from the date of purchase, such defect(s) will be repaired, or replaced (with new or rebuilt parts) with Proof of Purchase, at the Company's option, without charge for parts or labor directly related to the defect(s).

NOTE

If the warranty period is inconsistent with local laws and regulations, please comply with the relevant local laws and regulations.

The Company shall not be liable for any incidental or consequential damages arising from the use, misuse, or mounting of the device. Some states do not allow limitations on how long an implied warranty lasts, so the above limitations may not apply to you.

This warranty does not apply to:

- a) Products subjected to abnormal use or conditions, accident, mishandling, neglect, unauthorized alteration, misuse, improper installation or repair or improper storage;
- b) Products whose mechanical serial number or electronic serial number has been removed, altered or defaced;
- c) Damage from exposure to excessive temperatures or extreme environmental conditions;
- d) Damage resulting from connection to, or use of any accessory or other product not approved or authorized by the Company;
- e) Defects in appearance, cosmetic, decorative or structural items such as framing and non-operative parts;
- f) Products damaged from external causes such as fire, dirt, sand, battery leakage, blown fuse, theft or improper usage of any electrical source.

! **IMPORTANT**

All contents of the product may be deleted during the process of repair. You should create a back-up copy of any contents of your product before delivering the product for warranty service.

AUTEL[®]